

Catálogo de Produtos

LINHA PESADA

MAGNETI MARELLI

COFAP



MAGNETI MARELLI

- bateria
- bomba d'água
- bomba d'água e óleo premium
- compressor
- correia
- máquina rotante
- filtro de ar, óleo, combustível e cabine
- lâmpada
- linha térmica
- válvula termostática

COFAP

- amortecedor
- mola a gás
- mola pneumática
- camisa para motor
- kit para motor

LINHA DE PRODUTOS COFAP

AMORTECEDOR

Agrale, Ford.....	04
General Motors.....	05
International, Iveco, Mercedes-Benz.....	06
Puma, Randon, Scania.....	12
Volkswagen.....	13
Volvo.....	14

MOLA A GÁS, AMORTECEDOR PARA CABINE, BANCO, DIREÇÃO, MOTOR E EIXO TRASEIRO

Características técnicas - mola a gás e diagrama de cálculo.....	16
Agrale, Encarroçadoras, Ford e Mercedes-Benz.....	18
Scania, Volkswagen e Volvo.....	19
Cross Reference amortecedores e mola a gás.....	20

MOLA PNEUMÁTICA

ÔNIBUS

Mola cilíndrica e convolutada.....	22
Bolsa cilíndrica e convolutada.....	30
Kit pneumático.....	40

CAMINHÕES E CARRETAS

Mola cilíndrica e convolutada.....	44
Bolsa cilíndrica e convolutada.....	50

COMPONENTES PARA MOLA PNEUMÁTICA

ÔNIBUS, CAMINHÕES E CARRETAS

Batente.....	54
Tampa.....	56
Base.....	58
Cross Reference - Mola Pneumática.....	63

CAMISA E KIT PARA MOTOR

Agrale, Atlas Copco.....	67
Bantam Emaq, Barber-Greene.....	68
Brasmecânica (Toro), C. Cifali, CBT.....	69
Case.....	70
Caterpillar, Clark.....	71
Coles/ Bardela, Cummins.....	72
Dodge (Chrysler), Dresser (Huber Wabco).....	73
Dynapac.....	74
Eaton/ Yale.....	75
Engesa, Fendt, Fiat Allis.....	76
FNV-Bucyrus, Ford Tratores.....	77
Gardner Denver (compressor), General Motors, Hoekuetsu (compressor), Holman Compair (compressor), Hoos (compressor).....	78
Ingersoll Rand (compressor).....	79
Mercedes-Benz.....	80
MWM.....	82
Perkins.....	83
Puma, Randon, Scania.....	84
Volkswagen.....	85
Volvo.....	86

Desenhos técnicos.....	88
Lista numérica.....	91
Tabela de conversão.....	92

LINHA DE PRODUTOS MAGNETI MARELLI

BATERIA PARA CAMINHÕES E ÔNIBUS

Agrale, Chrysler, Ford, General Motors- Chevrolet, Iveco, Mercedes-Benz.....	98
Scania, Volkswagen.....	99
Volvo.....	100
Características técnicas e cuidados especiais.....	101

BATERIA PARA MÁQUINAS AGRÍCOLAS, EMPILHADEIRAS E TERRAPLANAGEM

AGCO-Massey Ferguson, Agrale tratores, Case (J. J. Case), Caterpillar, Clark tratores, Engesa.....	102
Fiat Allis, Huber Wabco/ Dresser, John Deere, Komatsu, Malves, Müller, New Holland.....	103
Poclair, Randon, Svedala Dynapac, Tema Terra, Terex, Valmet/ Valtra.....	104
Volvo Construction Equipment, Wabco, Yale, Zector.....	104
Cross reference.....	105
Procedimentos de recarga.....	106

BOMBA D'ÁGUA

AGCO.....	108
Agrale, Case, CBT.....	109
Chevrolet.....	110
Clark, Dynapac.....	111
Fiat Allis, Ford.....	112
Hyster, Ideal, JI Case, Marcoplan.....	115
Massey Ferguson, Maxion, Mercedes-Benz.....	116
MWM, Perkins.....	124
Scania, Valmet.....	125
Volkswagen.....	127

BOMBA D'ÁGUA PREMIUM

Iveco, Scania.....	130
--------------------	-----

BOMBA DE ÓLEO PREMIUM

Iveco, MWM.....	130
-----------------	-----

COMPRESSOR

Iveco, Scania, Volvo.....	130
---------------------------	-----

CORREIA AUTOMOTIVA PARA CAMINHÕES

Agrale, Fiat, Ford, General Motors.....	133
International, Iveco, Mercedes-Benz.....	134
Scania.....	135
Volkswagen.....	136

CORREIA AUTOMOTIVA PARA ÔNIBUS

Agrale, Ford, Mercedes-Benz.....	139
Scania, Volare.....	140
Volkswagen, Volvo.....	141

CORREIA AUTOMOTIVA PARA MÁQUINAS E IMPLEMENTOS AGRÍCOLAS

Agrale, Baber Greene, Caterpillar, CBT, Claas Consul, Clark Consul.....	143
Clayson Consul, Cummins Motors, Eaton, Fiat Allis, Ford, Hyster.....	144
Ideal Standard, Komatsu, Lavrale, Massey Ferguson.....	145
Müller, MWM, New Holland, Santa Matilde, Schneider Logemann, SLS John Deere, Sperry New Holland, Tema-Terra.....	146
Terex, Valmet, Valtra Valmet, Yanmar Valmet.....	147

FILTRO DE AR, ÓLEO, CABINE E COMBUSTÍVEL - CAMINHÕES E ÔNIBUS

Agrale.....	150
Clark, Fiat.....	151
Ford.....	152
General Motors.....	158
Iveco.....	159
Maferesa, Matra, Mercedes-Benz.....	160
Puma, Randon, Santa Matilde, Scania.....	171
Volvo.....	175
Volkswagen.....	179

LÂMPADAS AUTOMOTIVAS

Agrale, Ford, Iveco, Kia Motors, Mercedes-Benz.....	189
Peugeot, Renault, Scania.....	193
Volkswagen.....	194
Volvo.....	195
Índices de bases.....	196

MÁQUINA ROTANTE

Designações de terminais.....	198
Regulador de voltagem.....	199
Designações de terminais.....	208
Retificador.....	209
Designações de terminais.....	218
Módulo de Ignição.....	219

LINHA TÉRMICA

Ford, Iveco, Mercedes-Benz/ Daimler Chrysler.....	223
Scania.....	225
Volkswagen, Volvo.....	226
Desenhos Técnicos.....	230

VÁLVULA TERMOSTÁTICA

Caterpillar, Cummins.....	244
Mercedes-Benz, MWM, Scania.....	245
Volkswagen, Volvo.....	246
Guia e consulta.....	246

linha de
produtos



amortecedor



amortecedor

MARCA/ MODELO



AGRALE

CAMINHÕES

TX-1200 / 1600 D / 1800 D

Todos os modelos

L.12786

00

L.12787

00

4500 / 5000

Todos os modelos

L.12095

00

L.12096

00

FURGOVAN

6000

L.12592

00

L.12861

00

8000

L.12860

00

L.12861

00

7000 / 7500 / MA-7.5 T

Netuno

L.12024

00

L.12025

00

7500 / 8500

L.12859

00

8.500 T

Netuno

L.12120

00

L.12121

00

ÔNIBUS

MA-5.0 T

Volare / Senior

L.12667

00

L.12065

00

MA-6.0 T

Volare / Senior - A6 / A8

L.12472

00

L.12473

00

MA-7.5 T / MA 8.0 T / MA-8.5T / MA-8.5T SUPER

Volare / Senior / W8

L.12503

00

L.12504

00

MA-7.5 T / MA-8.5T

Volare / Senior - A6 / A8 Suspensão a ar

L.12871

00

L.12872

00

MA-10.0

Todos os modelos

L.13159

00

L.13160

00

Ref. Original Dianteiro 6012.014.164.00.7

45275

+

MA-12.0

Todos os modelos

45219

00

45220

+

MA-15.0

45282

00

ÔNIBUS COM SUSPENSÃO A AR

Ref. Original Dianteiro 8036005X01

L.12556

00

MICRO ÔNIBUS

MA-9.2 TCA

MA-9.2 TCA - Urbano

L.12700

00

L.12701

00

MA-9.2 TCA - Executivo

L.13053

00

L.13054

00

VOLARE A5

L.12881

00

L.12882

00

VOLARE A8W RHD - Ref Original Traseiro 6013.014.009.00.2

L.12592

00

L.13059

00

FORD

CAMINHÕES

CANAVIEIRO

Todos os modelos

45094

00

CARGO

712 / C814 / 814 / 815 / 815S / C815E / 915

05.96 / ...

L.12591

00

L.12476

00

1113 / 1114 / 1117 / 1218

45090

00

1215 / 1217 / 1415 / 1417 / 1421 / 1422

45086

00

45090

00

1313 / 1314 / 1317 / 1418 / 1419

... / 06.91

45069

00

45056

00

1317E / 1517E

01.08 / ...

45286

00

1419

07.91 / ...

45069

00

45090

00

1521

02 / 05

45069

00

45090

00



Linha de produtos Cofap
Amortecedor



amortecedor

MARCA/ MODELO					
---------------	--	--	--	--	--

FORD (cont.)

CARGO					
1514 / 1517 / 1615 / 1617 / 1618 / 1619 / 1622		45069	00	45087	00
1621 / 1630		45086	00	45087	00
1717E		45086	00	45087	00
1717 / 2322 / 2421 / 2422 / 2425 / 2428 / 2622 / 2631 / 3224 / 3530		45086	00		
1721 / 1731	02 / 05	45086	00	45091	00
1722E / 2422E / 2428E		45086	00		
1722E / 2422E / 2428E - MAX TRUC	03.08 / ...	45276	00		
2213 / 2217 / 2218 / 2319 / 2324 / 2630 / 2631 / 3222		45069	00		
2626 / 4031	02 / 06	45086	00		
2622E / 2628E / 2632E / 2932E / 5032E / 6332E		45094	00		
2831	05 / 06	45094	00		
4030	94 / 04	45086	00		
4331 / 4432E / 4532E		45214	00	45215	00
4432	06 / 08			45215	00
5031	05 / 05	45094	00		
F-350					
N 4X2	96 / ...	GL12723	00	GL12724	00
F-400 / FB-4000					
Exceto Repowering	... / 12.95	L.12680	00	L.12977	00
F-4000					
Exceto Repowering	75 / 12.95	L.12680	00	L.12977	00
Repowering	... / 10.98	L.12680	00	L.12066	00
Repowering	11.98 / ...	GL13080	00	L.12066	00
F-600 / 700 / 750					
Todos os modelos	... / 79	L.12755	00		
F-7000 / 11000 / 13000					
Todos os modelos	... / 04.92	L.12755	00		
F-12000					
Todos os modelos	80 / 04.92	L.12755	00		
Todos os modelos	05.92 / 98	L.12668	00		
Todos os modelos	99 / ...	L.13297	00		
F-14000					
Todos os modelos	88 / 04.92	L.12994	00		
Todos os modelos	05.92 / 98	L.12668	00		
Todos os modelos	99 / ...	L.13297	00		
F-16000 / 19000 / 21000 / 22000					
Todos os modelos	80 / 04.92	L.12994	00		
F-16000					
Todos os modelos	99 / ...	L.13297	00		
ÔNIBUS					
B-12000 / B-1618 / B-1621 - Beta					
Todos os modelos		45095	00	45096	00

GENERAL MOTORS

CAMINHÕES					
A/C/D-40					
Todos os modelos	85 / 95	L.12648	00	L.12649	00

05



MARCA/ MODELO



GENERAL MOTORS (cont.)

A/C/D-60/70

Todos os modelos

L.12749



6000 / 6000T / 6100 / 6150

Todos os modelos

L.12648



L.12649



D-11000 / 12000 / 13000 / 14000 / 19000 / 21000 / 22000

Todos os modelos

45049



12-170 / 14-190 / 15-190

Curto

45164



Longo

45151



16-220

Longo

45151



INTERNATIONAL

CAMINHÕES

NAVISTAR

4700 / 4900

01 / 02

45168



L.12144



9200 / 9800

01 / 02

45168



45169



IVECO

CAMINHÕES

DAILY

35.10 / 49.10 / 49.12

GL12833



GL12834



59.12 / 60.12

02 / ...

GL12880



GL12879



70C16

GL12761



GL12814



EUROTECH

Ref. Original: Dianteiro 41296205 - Traseiro 99484635

L.13333



L.13334



SCUDATO

59.12

01 / 05

GL12880



GL12879



STRALIS

Ref. Original: Dianteiro 503346518 - Traseiro 7144240

L.13331



L.13332



VERTIS

Ref. Original: Dianteiro 05949890362 - Traseiro 05949890992

GL13256



GL13257



MERCEDES-BENZ

CAMINHÕES

ACCELO

715 C / 915 C

03 / ...

L.12142



45210



ATEGO

1315 / 1418 / 1718 / 1725 - COM MOLA CURTA

04 / ...

L.13183



L.12981



1315 / 1418 / 1718 / 1725 (EXCETO COM MOLA CURTA)

04 / ...

L.13183



45227



1718 / 1725 (SUSPENSÃO REFORÇADA)

04 / ...

L.13183



45228



1728

07 / ...

L.12013



2425

05 / ...

L.13183



AXOR

1933S

05 / ...

L.13282



45352



3340 - Ref. Original Dianteiro A.958.323.1700 - Traseiro A.958.326.1100

05 / ...

L.13322



45376



3340 / 3340K / 3340S -

05 / ...

L.13322



45374



Ref. Original Dianteiro - A.958.323.1700 - Traseiro A.958.326.6000

3344 / 3344K / 3344S -

05 / ...

L.13322



45374



Ref. Original Dianteiro - A.958.323.1700 - Traseiro A.958.326.6000

4140K - Ref. Original Dianteiro A.958.323.1700 - Traseiro A.958.326.6000

06 / ...

L.13322



45374



2035S / 2040S / 2044S -

05 / ...

L.13326



45375



Ref. Original Dianteiro - A.958.323.1000 - Traseiro A.958.326.0800



Linha de produtos Cofap
Amortecedor



amortecedor

MARCA/ MODELO



MERCEDES-BENZ (cont.)

AXOR

2644S - Ref. Original Dianteiro A.958.323.1300 - Traseiro A.958.326.0900	05 / ...	L.13323	00	45377	00
2644S - Ref. Original Dianteiro A.958.323.0700	05 / ...	L.13324	00		
2644S - Ref. Original Dianteiro A.958.323.1200	05 / ...	L.13347	00		
2826 - Ref. Original Dianteiro A.958.323.0800 - Traseiro A.958.326.6000	06 / ...	L.13325	00	45374	00
2828K / 2831 - Ref. Original Dianteiro - A.958.323.0500 - Traseiro A.958.326.6000	06 / ...	L.13327	00	45374	00
2540S / 2544S / 2640 - Ref. Original Dianteiro A.958.323.0700	05 / ...	L.13324	00		

CAMINHÃO HPN

HPN				45079	00
608					
L	... / 94	B.47417	00	B.47417	00
		B.47417	00	B.47417	00
610 / 708					
L		B.47417	00	B.47417	00
709 / 710					
Todos os modelos		B.47498	00	B.47498	00
712					
Todos os modelos		B.47801	00	L.12896	00
712 C					
Eletrônico	06.98 / ...	B.47801	00	B.47801	00
912 / 914 / 914C					
Todos os modelos		L.12896	00	L.12896	00
1113					
L / LS / LK		L.12917	00		
LA / LAK / LAS		B.47422	00		
1114					
L / LS		L.12917	00		
LK		L.12770	00	45043	00
1116					
L / LK		L.12917	00		
LA / LAK / LAS		B.47422	00		
1118					
L / LK		L.12917	00		
1214					
L / LK		L.12670	00		
		L.12670	00	45123	00
1215 C					
Todos os modelos		L.12670	00	45170	00
1218					
L / LK		L.12670	00		
		L.12670	00	45123	00
1313					
L / LK		L.12770	00	45043	00
LA / LAK / LS		L.12670	00	45123	00

Obs.: d - Em desenvolvimento

07



amortecedor

MARCA/ MODELO



MERCEDES-BENZ (cont.)

1314 L / LK		L.12770	00	45043	00
LA / LAK		L.12670	00	45123	00
1316 L / LK		L.12770	00	45043	00
LA / LAK / LS		L.12670	00	45123	00
1317 L / LK		L.12770	00	45043	00
LA / LAK		L.12670	00	45123	00
1318 L		L.12770	00	45043	00
LK		L.12670	00	45123	00
1319 L		L.12770	00	45043	00
1414 L / LK		L.12670	00	45123	00
1418 L		L.12670	00	45123	00
K		L.12770	00	45043	00
L / LA / LAK / LK		L.12670	00	45123	00
1420 Todos os modelos		L.12670	00	45123	00
1513 / 1514 / 1516 / 1517 / 1518 L / LK		L.12670	00	45123	00
1519 / 1520 L / LK		L.12670	00	45123	00
LS		L.12670	00	45006	00
1524 / 1525 LS		L.12670	00	45006	00
1614 LS		L.12670	00	45123	00
1618 L / LK		L.12670	00	45123	00
M		L.12770	00	45170	00
1620 L		L.12770	00	45125	00
LK		L.12770	00	45152	00
1621 L / LK		L.12670	00	45123	00
1622 L - Eletrônico		L.12670	00	45170	00
1625 L / LK		L.12670	00	45123	00
LS		L.12752	00		
1630 LS		L.12752	00	45083	00
1632 L		L.12493	00		

OB

Linha de produtos Cofap
Amortecedor



amortecedor

MARCA/ MODELO



MERCEDES-BENZ (cont.)

1632 / 1634					
LS		L.12128	00	45147	00
1714 / 1718 / 1720 / 1721 / 1723					
Todos os modelos		L.12670	00	45123	00
1728					
Todos os modelos		L.12770	00	45152	00
1929					
L		L.12318	00		
LS		L.12646	00		
1924 / 1932 / 1933 / 1934					
LS		L.12646	00		
1935					
L		L.12770	00	L.12796	00
LS		L.12770	00	45152	00
1938					
L		L.12143	00	45146	00
LS		L.12143	00	45146	00
LS Eletrônico		L.12770	00	L.12796	00
S		L.12474	00	L.12447	00
		L.12143	00	45146	00
1941					
L / LS		L.12770	00	L.12796	00
L / LS (suspensão reforçada)		L.12770	00	45152	00
1944					
S		L.12143	00	45146	00
2013 / 2014 / 2016 / 2017 / 2225 / 2314 / 2316					
L		L.12752	00		
2038 / 2414 / 2416 / 2418 / 2423 / 2428					
L		L.12131	00		
2213 / 2214 / 2215 / 2216 / 2217 / 2219 / 2220 / 2318 / 2325					
L / LB / LK		L.12752	00		
2635					
L / LS		L.12770	00	L.12796	00
L / LS (suspensão reforçada)		L.12770	00	45152	00
LK		L.12770	00		
2638					
L / LS / LK		L.12128	00		
ÔNIBUS					
608 / 610 / 708 / 809 / 812 / 814 / 912 / 914					
LO		L.12896	00	L.12896	00
915					
LO	04 / ...	L.12142	00		
1111					
LP / LPO		L.12918	00	45003	00

Obs.: d - Em desenvolvimento

09



























































amortecedor

MARCA/ MODELO



MERCEDES-BENZ (cont.)

1113					
LP / LO / LPO		L.12918		45003	
1114 / 1313					
LPO		L.12918		45003	
1116					
LO		L.12918		45003	
METRÓPOLIS					
		L.12745			
O-321					
		45015			
LP		45015			
O-326 / 352 / 355 / 362					
Todos os modelos		45015			
O-364 / 365					
Todos os modelos		45015		45027	
O-370					
U / UL / UP - Urbano / Rodoviário		L.12661		45059	
R / RS / RSD / RSE / RSL - Suspensão a ar - Rodoviário		L.12657		L.12657	
O-371					
U / UL / UP - Urbano / Rodoviário		L.12661		45059	
R / RS / RSD / RSE / RSL - Suspensão a ar - Rodoviário		L.12657		L.12657	
Com Mola Helicoidal				45098	
O-400					
U / UL / UP - Urbano / Rodoviário		L.12661		45059	
R / RS / RSD / RSE / RSL - Suspensão a ar - Rodoviário		L.12657		L.12657	
RS / RSD - Rodoviário		45167			
O-500					
1632 / 1725	01 / ...	45173			
Articulado	06 / ...	45188		45188	
1726	06 / ...	45188		45188	
1728	05	45188		45188	
1732	05 / 06	45188		45188	
CBC 2632 - Ref. Original nº A3823260400				L.12605	
CBC 2632 - Ref. Original nº A3823260300 Eixo Intermediário				L.12722	
R 1830	05 / ...	45188		45188	
RS 1636	04 / 05	45188		45188	
RS 1836	05 / ...	45188		45188	
RSD 2036	04 / 05	45188		45188	
RSD 2236	05 / ...	45188		45188	
RSD 2336	07	45188		45188	
RSD 2436	09 / ...	45188		45188	
U 1726	08	45188		45188	
OF-1113 / 1114 / 1316 / 1513 / 1618					
Suspensão Reforçada		45122		45123	
		L.12757		45123	
OF-1115					
Todos os modelos		L.12918		45003	
OF-1313 / 1314 / 1315 / 1318					
Suspensão Reforçada		45122		45123	



Linha de produtos Cofap
Amortecedor



amortecedor

MARCA/ MODELO					
---------------	--	--	--	--	--

MERCEDES-BENZ (cont.)

OF-1313 / 1314 / 1315 / 1318			L.12757	00	45123	00
OF-1417						
Suspensão Reforçada			45122	00	45123	00
Urbano			L.12483	00	45148	00
OF-1418						
Caminho da Escola			L.13274	00		
OF-1421 / 1621 / 1623 / 1625 / 1630 / 1635						
Todos os modelos			45126	00	45127	♀
OF-1518						
XBC - Todos os modelos	04 / ...		45240	00	L.13097	00
OF-1620						
Todos os modelos			L.12757	00	45123	00
OF-1721						
Todos os modelos			L.12448	00	45136	00
OF-1732						
Todos os modelos			L.12448	00	45221	00
OF-809 / 812						
Todos os modelos			L.12896	00	L.12896	00
OH-1313						
Suspensão Reforçada			45122	00	45123	00
			L.12757	00	45123	00
OH-1315 / 1316 / 1318 / 1418 / 1419 / 1420 / 1421 / 1517/ 1520						
Suspensão Reforçada			45122	00	45123	00
			L.12757	00	45123	00
OH-1513						
Suspensão Reforçada			45122	00	45123	00
OH-1518						
Suspensão Reforçada			45122	00	45123	00
			L.12757	00	45123	00
Ref. Original: Traseiro A 368 326 02 00	d				L.13155	00
OH-1417						
Todos os modelos			45172	00	L.12146	00
OH-1621 / 1623 / 1625 / 1628 / 1630 / 1635 / 1636						
Todos os modelos			L.12377	00	45123	00
OHL-1421 / 1623 / 1625 / 1630 / 1635						
Todos os modelos			45126	00	45127	♀
OHL-1621						
Suspensão a ar			45126	00	45127	♀
			L.12130	00	45127	♀
OHL-1636						
Suspensão a ar			L.12130	00	45127	♀
ÔNIBUS 10 / 12 TONELADAS						
Ref. Original: Dianteiro A 384 323 03 00 - Traseiro A 384 326 02 00			45249	♀	L.13220	00
Ref. Original: Dianteiro A 384 323 05 00 - Traseiro A 384 326 02 00			45311	♀	L.13220	00

Obs.: d - Em desenvolvimento



amortecedor

MARCA/ MODELO



PUMA

CAMINHÕES

914

Cabine Simples / Cabine Dupla

L.12977



L.12977



7900

CB

L.12896



L.12896



CD

L.12896



L.12896



RANDON

CAMINHÕES

CARRETAS RANDON - CAMINHÃO REBOQUE

Suspensão Pneumática - 3º Eixo

45193



45145



CAMINHÃO VOLKSWAGEN

18.310

45189



45189



CAMINHÃO FORA DE ESTRADA

45011



CHASSI RANDON

Eixo direcional: amortecedor montado na horizontal

45175



ÔNIBUS

O-500

3º Eixo

45188



45188



SCANIA

CAMINHÕES

110 / 111

L / LK / LS / LT - Suspensão c/ Mola

L.12052



140 / 141

LK / LT / LKS / LKT / LHS

45033



112 / 113 / 142 / 143

R / T

45033



SÉRIE 4

P-93 / 94 / 114 / 124 - Suspensão a ar

45155



R / T-114 / 124 - Suspensão a ar

45155



ÔNIBUS

B-110

Suspensão c/ Mola

45010



45016



B-111 - BR-115 / 116

Suspensão c/ Mola

45010



45016



Suspensão a ar

45010



45021



L-111

Suspensão a ar

45010



45021



F-94

Com motor dianteiro

45141



45142



4x2

45195



45142



F-112 / 113

Todos os modelos

45033



45074



K-112 / 113

Suspensão a ar

45077



45078



Suspensão a ar 3º Eixo

45057





Linha de produtos Cofap
Amortecedor



MARCA/ MODELO					
---------------	--	--	--	--	--

SCANIA (cont.)

K-112 / 113 Suspensão com Mola		45050		45051	
L-113 Suspensão a ar		45077		45078	
Suspensão a ar 3º Eixo				45057	
S-112 / 113 Suspensão com Mola		45050		45051	
K-124 / 94 - L-94 Suspensão a ar		45156		45078	
3º Eixo				45163	
K114 / K124 / K94 / L94 4x2 / 6x2 - Todos os modelos		45156		45078	
ÔNIBUS ARTICULADO EIXO DE APOIO				45190	

VOLKSWAGEN

CAMINHÕES					
6.80 / 6.90 / 7.90 / 7.110 Todos os modelos	... / 03.94	L.12631		L.12632	
7.100 / 7.120 / 8.100 / 8.120 / 8.140 / 8.150 7 e 8 Toneladas		L.12477		L.12476	
Caminhão 7/8 T 7 e 8 Toneladas				L.13221	
DELIVERY 5.140 / 8.150 Chassi 2850MM		L.12477		L.12476	
Chassi 4300MM		L.12477		L.12476	
9-150 NFB		L.12996		L.12997	
11.130 / 11.140 / 11.160 / 13.130 Todos os modelos	82 / ...	L.12614		45036	
12.140 / 12.170 / 12.180 / 13.150 / 13.170 / 13.180 / 13.190 / 14.140 / 14.150 / 14.170 / 14.180 / 14.200 / 14.220 / 15.170 / 15.180 / 15.190 Todos os modelos		45086		45090	
Constellation 13180E / 15180E Todos os modelos		45086		45090	
Constellation 17250E / 24250E Distância entre eixo 3560MM		45086		45087	
Distância entre eixo 4340 / 4800 / 5207MM		45086		45091	
Constellation 19320E / 25370E Suspensão traseira mecânica		45086			
Suspensão traseira pneumática		45234			
Constellation 19.370 / 25.320 Todos os modelos		45234		45189	
14.210 Distância entre eixo 3560MM	... / 10.89	L.12614		45036	
Distância entre eixo 4340 / 4800 / 5207MM	11.89 / ...	L.12614		45056	



amortecedor

MARCA/ MODELO



VOLKSWAGEN (cont.)

16.210					
Todos os modelos	... / 12.90	45075	oo	45056	oo
16.170 / 16.200 / 16.220 / 16.300 / 17.210 / 17.220 / 17.300 / 17.310 / 18.310 / 35.700 / 40.300					
Todos os modelos		45086	oo	45091	oo
17.180 EIII / 25.360					
Todos os modelos		45086	oo		
23.210 / 23.220 / 23.250 / 23.310 / 24.220 / 24.250					
Todos os modelos		45094	oo		
26.220 / 26.260 / 26.300 / 26.310 / 31.260 / 31.310 / 31.320					
Todos os modelos		45094	oo		
CAMINHÃO DE LIXO					
		45174	oo		
ÔNIBUS					
7.90 / 7.110					
Todos os modelos		L.12631	♀	L.12632	oo
15.180 / 15.190 / 16.180 - Beta					
Urbano		45095	oo	45096	oo
Rodoviário		45137	oo	45096	oo
16.210 / 17.210 - Beta					
Todos os modelos		45095	oo	45096	oo
17-230 EOD					
	06 / ...	45095	oo	45096	oo
8.140 / 8.150 / 9.150					
Micro ônibus - Chassi Longo / Curto		L.12477	♂	L.12476	oo
5.140 / 8.150					
Micro ônibus Dedalus Delivery		L.13092	oo	L.13093	oo
17.240 / 17.260					
Proteus - Com motor traseiro - Ref. Original: Dianteiro 2Z0 413031	01 / ...	L.12151	oo	45160	oo
Proteus - Ref. Original: Dianteiro 2Z0 413031A	01 / ...	L.12198	oo	45160	oo
17.260E OT / 18320E OT					
Queops / Proteus	06.06 / ...	45229	oo		
18.310 OT					
Todos os modelos		45229	oo	45160	oo
MICRO ÔNIBUS / FURGÃO					
7,3 Toneladas		L.12602	oo	L.13223	oo

VOLVO

CAMINHÕES					
FM 10/12 - NF / FH-12					
4X2 Suspensão a Mola	96 / 06	45182	oo		
6X4 Suspensão a Mola	96 / 06	45182	oo	45185	♀
N-10					
Todos os modelos	80 / 83	45029	oo		
Todos os modelos	84 / 89	45063	oo	45093	+
N-12					
Todos os modelos	84 / 89	45063	oo	45093	+



Linha de produtos Cofap
Amortecedor



MARCA/ MODELO					
VOLVO (cont.)					
NL-10 / 12					
Todos	89 / 92	45063		45093	+
C/ Mola Parabólica	93 / 00	45092		45093	+
ÔNIBUS					
B-7R					
Todos os modelos	98 / ...	45165		45166	♀
B-10 M / R					
	86 / 06	45119		45120	
3° Eixo	86 / 06			45121	♀
B-12 M / B / R					
	94 / ...	45165		45120	
3° Eixo	94 / ...			45121	♀
B-58					
Suspensão a Ar	80 / 99	45117		45118	
3° Eixo	80 / 99			45039	

LEGENDA

	Instalação na dianteira
	Instalação na traseira
	Tipo de fixação / montagem
	Argola no topo Argola na base
	Argola no topo Pino na base
	Pino no topo Argola na base
	Pino no topo Pino na base

CARACTERÍSTICAS TÉCNICAS - MOLA A GÁS

A Mola a Gás Cofap é um dispositivo monotubular pressurizado, cujo pistão se encontra permanentemente submetido a uma pressão imposta por um gás existente dentro do tubo.

Uma das vantagens com relação às molas convencionais é a de poder armazenar uma grande quantidade de energia em um volume reduzido.

São mais leves, seguras, econômicas e uma de suas características mais importantes é a de manter praticamente constante a força inicial, com pequenas variações do valor nominal.

Também são elementos estruturais que substituem não somente as molas mecânicas, mas todo o sistema de sustentação de carga.

Essas características de desempenho fazem da mola a gás, em muitos casos, a única solução técnica e economicamente viável para uma grande quantidade de aplicações.

Pelas características especiais, as molas a gás desempenham diversas funções: abrir, levantar, amortecer, sustentar fechar portas e equipamentos.

Sua aplicação se dá principalmente na linha automotiva, podendo também ser facilmente encontrada em outros tipos de utilização.

DIAGRAMA DE CÁLCULO

A seguir, apresentamos o processo de cálculo para o desenvolvimento de uma Mola a Gás, com as informações necessárias para se definir a força, tipo de projeto, curso e tamanho do corpo.

Inicialmente determina-se o valor da força da Mola a Gás na posição aberta, seguindo a fórmula mostrada abaixo:

- | | |
|--|---|
| A - Ponto de ligação porta / estrutura | G - Centro de gravidade da porta |
| B - Ponto de apoio da Mola a Gás com porta | P - Peso da porta (N) |
| C - Ponto de apoio Mola a Gás com a estrutura | F1 - Força da Mola a Gás com a porta aberta |
| D - Dimensão de A a B (porta aberta na horizontal) | α - Ângulo da Mola a Gás com a porta aberta |
| E - Dimensão de A a G (porta aberta na horizontal) | β - Ângulo a ser formado pela Mola a Gás a fim de haver força para manter a porta fechada |

$$F1 = \frac{P \times E}{D \times \sin \alpha} + 5 \text{ a } 10 \% \text{ de segurança}$$

CARACTERÍSTICAS TÉCNICAS

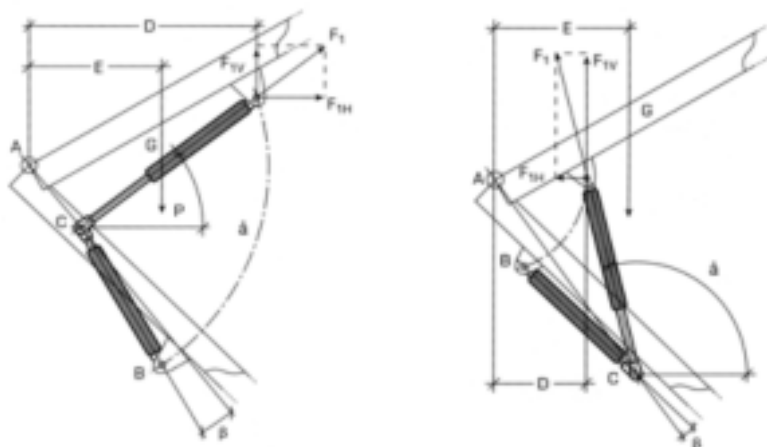

Depois de se obter o valor de F1, escolher o tipo de projeto de Mola a Gás compatível com força F1 desejada, seguindo a tabela abaixo:

Tipo de Projeto		
ø Haste	ø Tubo	(F1) máx.
6	15	350
8	19	600
8	22	600(*)
10	22	1000

(*) Projeto Especial

linha de
produtos

Xceltop

**mola a gás,
amortecedor para
cabine, banco, direção,
motor e eixo traseiro**



Linha de produtos Cofap
Mola a gás,
amortecedores para cabine,
banco, direção, motor
e eixo traseiro



MARCA/ MODELO	TIPO	APLICAÇÃO		POSIÇÃO	CÓDIGO COFAP	Fixação Superior	Fixação Inferior
AGRALE							
CAMINHÕES							
FURGOVAN 6000	Cabine	Todos		Cabine	B.47585	A	A
ENCARROÇADORAS							
CAIO / IRIZAR	Mola a gás			Tampa Traseira	19039	248	251
CIA MANUFATUREIRA AUXILIAR	Mola a gás	ÔNIBUS COMETA - SCANIA		Tampa Tanque óleo	19046	248	251
	Mola a gás	ÔNIBUS COMETA - SCANIA		Tampa Bagageiro / Motor	19047	248	251
MARCOPOLO	Mola a gás			Tampa Pantográfica	16223	248	251
FORD							
CAMINHÕES							
CARGO	Cabine	Todos		Cabine	B.47585	A	A
F-4000	Direção			Direção	22052	A	P
F-4000	Direção	Ref. Original 2C353E651BA		Direção	CB27309	A	A
F-4000	Direção	Ref. Original 2C353651CA		Direção	CB27313	A	A
MERCEDES-BENZ							
CAMINHÕES							
AXOR	Banco	Ref. Original 40.050.250		Banco	B.48098	A	A
1214 / 1218 / 1618 / 1625 / 1630 / 1935 / 1941	Cabine	Cabine convencional sem leito		Cabine	B.47614	A	A
	Mola a gás	Cabine avançada - "Cara Chata"		Capô	B.47627		A
BANCO PARA MOTORISTA	Banco			Banco	B.47671	A	A
FPN	Mola a gás	Cabine avançada - "Cara Chata"		Capô Externo	16171	579	579
FPN 1214 / 1215 / 1218 / 1314 / 1414 / 1418 / 1420 / 1617 / 1714 / 1715 / 1718 / 1721 / 2414 / 2418	Cabine	Cabine avançada e cabine sem leito		Cabine	B.47683	A	A
FSK	Mola a gás			Tampa Motor	16285	579	579
L-1113 / 1313 até 1519 / 1525	Cabine	Cabine Simples		Cabine	B.47358	A	A
LS-1924 / 1929 / 1932 / 1933 / 1934	Cabine	Cabine Dupla		Cabine	B.47363	A	A
ÔNIBUS							
BANCO PARA MOTORISTA	Banco			Banco	B.47671	A	A
MOTOR OM-370 / 371	Motor			Esticador de Correia	22040	A	A
MOTOR OM-449 / 447	Motor			Motor	B.47710	A	A
O-370	Mola a gás			Tampa Bagageiro	19004	309	309
	Mola a gás			Tampa Bagageiro	19005	309	309
	Mola a gás			Tampa Motor	19020	309	309
	Direção			Direção	CL12150	Term. direção	A
	Direção			Direção	CL12784	Term. direção	A
O-371	Mola a gás			Tampa Bagageiro	19004	309	309
	Mola a gás			Tampa Motor	19036	309	309
	Mola a gás			Tampa Bagageiro	19038	309	309
	Banco			Banco	MGE8016	556	-
	Direção			Direção	CL12150	Term. direção	A
	Direção			Direção	CL12784	Term. direção	A
	Motor			Motor	B.47710	A	A

am's diversos e mola a gás

IB



Linha de produtos Cofap
Mola a gás,
amortecedores para cabine,
banco, direção, motor
e eixo traseiro



MARCA/ MODELO	TIPO	APLICAÇÃO		POSIÇÃO	CÓDIGO COFAP	Fixação Superior	Fixação Inferior
MERCEDES-BENZ (cont.)							
ÔNIBUS							
O-400	Mola a gás			Grade Dianteira	16120	579	579
	Mola a gás			Tampa da Geladeira	16135	604	604
	Mola a gás			Tampa Bagageiro	16233	579	579
	Mola a gás			Tampa Bagageiro	19005	309	309
	Mola a gás			Reserv. Sanitário	19005	309	309
	Mola a gás			Tampa Motor	19036	309	309
	Mola a gás			Tampa Traseira	19051	248	251
	Banco			Banco	MGE8016	556	-
ÔNIBUS	Direção	Todos com Terminal		Direção	CL12982	Term. direção	A
SCANIA							
CAMINHÕES							
BANCO PARA MOTORISTA	Banco			Banco	B.47671	A	A
CAMINHÕES	Cabine		... / 85	Cabine	B.47479	A	P
CAMINHÕES	Cabine		86 / ...	Cabine	B.47496	P	P
R-112 / R-142	Mola a gás			Tampa Motor	19034	556	251
	Mola a gás			Capô	19035	556	251
R-113	Mola a gás			Capô	19035	556	251
	Mola a gás	Ref Original 1681308		Tampa Capô	16252	248	251
R-143	Mola a gás			Capô	19035	556	251
SÉRIE 3 / SÉRIE 4	Banco	Todos		Banco	16320	309	309
SÉRIE 4 - P-94/114/124 R-114/124/164	Mola a gás	Ref Original 1306492		Tampa Capô	16256	579	579
VOLKSWAGEN							
CAMINHÕES							
DELIVERY 5.140 / 8.150 E	Cabine			Cabine	B.47898	A	A
COSTELLATION - 13.180E / 15.180E / 17.250E / 19.320E / 24.250	Cabine			Cabine	B.27352	A	A
VOLVO							
CAMINHÕES							
BANCO PARA MOTORISTA	Banco			Banco	B.47671	A	A
CHASSIS ATÉ 613485	Cabine			Cabine	B.47467	A	A
N10 / N12 CHASSI 613486	Cabine			Cabine	B.47792	P	P
NL10 / NL12	Cabine		... / 97	Cabine	B.47694	P	P
	Cabine	Exceto FH	98 / ...	Cabine	B.47792	P	P
ÔNIBUS							
B-10 M	Direção			Direção	CL12666	P	A



CÓDIGO
COFAP

CÓDIGO
MONROE

CÓDIGO
NAKATA

CÓDIGO
COFAP

CÓDIGO
MONROE

CÓDIGO
NAKATA

CROSS REFERENCE

16120		MG 16236	B.47363	37876	
16233		MG 16236	B.47417	37771	AC 30427
19004		MG 19238	B.47422	37780	AC 36014
19005		MG 16236	B.47467	37913	
19020		MG 19233	B.47479	37914	
19034		MG 16098	B.47496	37914	
19038		MG 19239	B.47498	38022	AC 30975
22040		MG 19654	B.47710		MG 16240
45003	70403		B.47792	37913	
45006	70406		CL12784	54448	
45010	70410		GL12723	27287	
45015	70407		GL12724	27283	
45016	70408		GL12833	27528	
45021	70409		GL12834	27529	
45027	70412		GL13080	27283	
45029	70416		L.12013	54502	
45033	70418		L.12052	54458	
45036	70428		L.12066	27284	AC 35972
45039	70413		L.12128	54425	
45043	70402		L.12130	54443	
45050	70419		L.12143	54463	AC 36016
45051	70423		L.12448	54444	AC 36013
45057	70442		L.12472	54454	
45059	70440	AC 36010	L.12473	54455	
45063	70462		L.12474	54449	
45069	70447		L.12476	54488	AC 36012
45074	70467		L.12477	54487	
45075	70451		L.12591		AC 36012
45077	70441		L.12592	38072	
45078	70409		L.12614	54431	
45083	70445		L.12631	54442	
45086	70447		L.12632	54441	
45090	70449		L.12646	54426	
45093	70455		L.12648	54477	AC 35945
45095	70459		L.12649	54478	AC 35946
45096	70459		L.12657	54475	AC 36010
45117	70415		L.12661	70475	
45118	70414		L.12668	54489	
45119	98514		L.12670	54386	AC 36017
45120	70466		L.12680	54412	AC 35818
45121	72060		L.12749	70437	
45122	70444		L.12755	54388	
45123	70461		L.12757	54427	
45126	70456		L.12770	54425	
45127	70457		L.12796	54463	
45136	70458		L.12871	54454	
45145	70463		L.12872	54455	
45146	70464		L.12896	38043	AC 31004
45147	54463		L.12917	54342	AC 30614
45148	70480		L.12918	54363	
45152	54463		L.12977		AC 35819
45155	70418		L.12994	54490	
45156	70465		L.13274	54495	
45167	54475	AC 36010	L.13282	54505	
45182	54496		L.13324	54506	
45188	54500		MGE8016		MG 16240
B.47358	37747	AC 25041			

linha de
produtos

Xeotop

**mola pneumática
para ônibus**

mola cilíndrica
e convolutada



MOLA CILÍNDRICA E CONVOLUTADA

BUSCAR 0500 RS		LEVANTE DO EIXO				
MOLA CONVOLUTADA COFAP MPC99201		CÓDIGO SIMILAR MOLA / BOLSA / KIT	TAMPA SUPERIOR	TAMPA INFERIOR	BATENTE	
		GOODYEAR	556 3 2 8631 556 3 3 8335	KTC99201	KBC99201	
		FIRESTONE	(095.0338) 333 T.2			
		CÓDIGO E.O.		ALTURA MÁXIMA	ALTURA MÍNIMA	DIÂMETRO MÁXIMO
		BUSCAR	61.386.917	420 mm	115 mm	360 mm
MAFERSA M210		EIXO DIANTEIRO / EIXO TRASEIRO				
MOLA CILÍNDRICA COFAP MPC99101	BOLSA PNEUMÁTICA COFAP BPC06101	CÓDIGO SIMILAR MOLA / BOLSA / KIT	TAMPA SUPERIOR	TAMPA INFERIOR	BATENTE	
		GOODYEAR	556 0 2 8404 556 0 3 8019	KTC99101	KBC06104	
		FIRESTONE	(095.0135) 1R1E-335-320			
		CÓDIGO E.O.		ALTURA MÁXIMA	ALTURA MÍNIMA	DIÂMETRO MÁXIMO
		ITAPEMIRIM		335 mm	162 mm	320 mm
SCANIA L 94 IB 4X2		EIXO DIANTEIRO				
MOLA CILÍNDRICA COFAP MPC06101	KIT PNEUMÁTICO COFAP KPC06103	CÓDIGO SIMILAR MOLA / BOLSA / KIT	TAMPA SUPERIOR	BASE	BATENTE	
		GOODYEAR	556 0 2 8562 556 0 3 8065 556 0 2 8465	KTC06102	KBC06105	
		FIRESTONE	(095.0482) 1T15MQX-3 095.0446			
		CÓDIGO E.O.		ALTURA MÁXIMA	ALTURA MÍNIMA	DIÂMETRO MÁXIMO
		SCANIA	1.44.03.01	335 mm	132 mm	350 mm
SCANIA	1.51.54.99					
		CÓDIGO DE REFERÊNCIA BOLSA COFAP BPC06103				



Linha de produtos Cofap
MOLA PNEUMÁTICA PARA ÔNIBUS
 Mola cilíndrica e convolutada



MOLA CILÍNDRICA E CONVOLUTADA

SCANIA L 94 IB 4x2		EIXO TRASEIRO				
MOLA CILÍNDRICA COFAP MPC06203	KIT PNEUMÁTICO COFAP KPC06203	CÓDIGO SIMILAR MOLA / BOLSA / KIT		TAMPA SUPERIOR	BASE	BATENTE
		GOODYEAR	556 0 2 8561 556 0 3 8063 556 0 2 8461	KTC06102	KBC06202	KBC06101
		FIRESTONE	(095.0481) 1T15LR-4 095.0416			
		CÓDIGO E.O.		ALTURA MÁXIMA	ALTURA MÍNIMA	DIÂMETRO MÁXIMO
		SCANIA	1.44.03.05			
		SCANIA	1.51.55.01	405 mm	219 mm	292 mm
		CÓDIGO DE REFERÊNCIA BOLSA COFAP BPC06203				
SCANIA L 94 UB 4X2		EIXO DIANTEIRO				
MOLA CILÍNDRICA COFAP MPC06102	KIT PNEUMÁTICO COFAP KPC06104	CÓDIGO SIMILAR MOLA / BOLSA / KIT		TAMPA SUPERIOR	BASE	BATENTE
		GOODYEAR	556 0 2 8564 556 0 3 8067 556 0 2 8460	KTC06102	KBC06106	KBC06103
		FIRESTONE	(095.0422) 1T15LR-4 095.0431			
		CÓDIGO E.O.		ALTURA MÁXIMA	ALTURA MÍNIMA	DIÂMETRO MÁXIMO
		SCANIA	1.44.03.03			
		SCANIA	1.47.51.06	445 mm	163 mm	280 mm
SCANIA	488.263	CÓDIGO DE REFERÊNCIA BOLSA COFAP BPC06104				
SCANIA L 94 UB 4X2		EIXO TRASEIRO				
MOLA CILÍNDRICA COFAP MPC06204	KIT PNEUMÁTICO COFAP KPC06206	CÓDIGO SIMILAR MOLA / BOLSA / KIT		TAMPA SUPERIOR	BASE	BATENTE
		GOODYEAR	556 0 2 8566 556 0 3 8069 556 0 2 8462	KTC06102	KBC06204	KBC06101
		FIRESTONE	(095.0481) 1T15LR-4 095.0416			
		CÓDIGO E.O.		ALTURA MÁXIMA	ALTURA MÍNIMA	DIÂMETRO MÁXIMO
		SCANIA	1.44.03.06			
		SCANIA	1.51.55.01	405 mm	224 mm	280 mm
		CÓDIGO DE REFERÊNCIA BOLSA COFAP BPC06206				

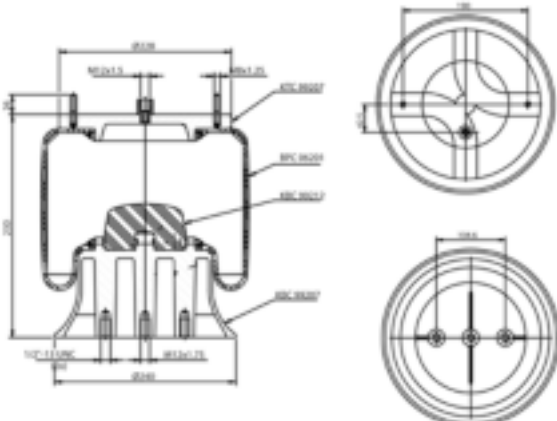
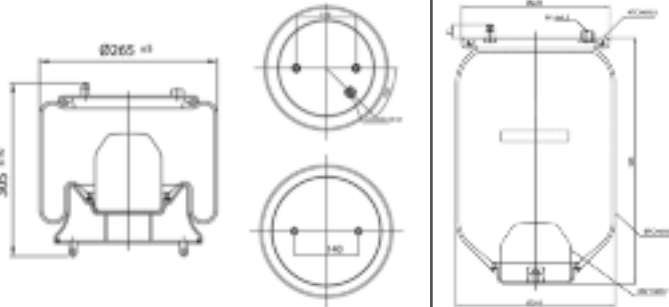
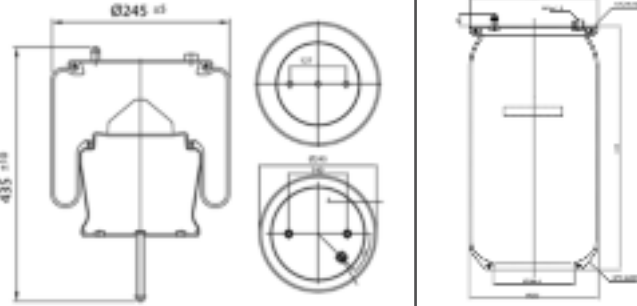

MOLA CILÍNDRICA E CONVOLUTADA

SCANIA K12		EIXO TRASEIRO / TERCEIRO EIXO			
MOLA CONVOLUTADA COFAP MPC06207		CÓDIGO SIMILAR MOLA / BOLSA / KIT	TAMPA SUPERIOR	BASE	BATENTE
	GOODYEAR	556 0 2 8426	KTC99207	KBC99207	KBC99212
	FIRESTONE	(095.0171) 1R1B-390-270			
	CÓDIGO E.O.		ALTURA MÁXIMA	ALTURA MÍNIMA	DIÂMETRO MÁXIMO
	SCANIA	1.67.31.90	400 mm	190 mm	270 mm
	SCANIA	523.975 / 524.070 533.800 / 539.982			
		CÓDIGO DE REFERÊNCIA BOLSA COFAP BPC06201			
SCANIA K124 EB 6X2		EIXO DIANTEIRO			
MOLA CILÍNDRICA COFAP MPC06103	KIT PNEUMÁTICO COFAP KPC06105	CÓDIGO SIMILAR MOLA / BOLSA / KIT	TAMPA SUPERIOR	BASE	BATENTE
	GOODYEAR	556 0 2 8565 556 0 3 8068 556 0 2 8464	KTC06102	KBC06107	KBC99102
	FIRESTONE	(095.0482) 1T15MQX-3 095.0446			
	CÓDIGO E.O.		ALTURA MÁXIMA	ALTURA MÍNIMA	DIÂMETRO MÁXIMO
	SCANIA	1.15.14.99	445 mm	182 mm	320 mm
	SCANIA	1.44.03.02			
SCANIA	488.266	CÓDIGO DE REFERÊNCIA BOLSA COFAP BPC06105			
SCANIA K124 EB 6X2		EIXO TRASEIRO			
MOLA CILÍNDRICA COFAP MPC06201	KIT PNEUMÁTICO COFAP KPC06203	CÓDIGO SIMILAR MOLA / BOLSA / KIT	TAMPA SUPERIOR	BASE	BATENTE
	GOODYEAR	556 0 2 8560 556 0 3 8063 556 0 2 8461	KTC06102	KBC06201	KBC06101
	FIRESTONE	(095.0481) 1T15LR-4 095.0416			
	CÓDIGO E.O.		ALTURA MÁXIMA	ALTURA MÍNIMA	DIÂMETRO MÁXIMO
	SCANIA	1.44.03.04 1.44.03.06	405 mm	219 mm	292 mm
	SCANIA	1.51.55.01			
SCANIA	470.922	CÓDIGO DE REFERÊNCIA BOLSA COFAP BPC06203			



Linha de produtos Cofap
MOLA PNEUMÁTICA PARA ÔNIBUS
 Mola cilíndrica e convolutada



MOLA CILÍNDRICA E CONVOLUTADA

SCANIA K124 EB 6X2		TERCEIRO EIXO				
MOLA CILÍNDRICA COFAP MPC06202	KIT PNEUMÁTICO COFAP KPC06205	CÓDIGO SIMILAR MOLA / BOLSA / KIT		TAMPA SUPERIOR	BASE	BATENTE
		GOODYEAR	556 0 2 8563 556 0 3 8066 556 0 2 8463	KTC06102	KBC06203	KBC06101
		FIRESTONE	(095.0405) / (095.0484) 1T15L-4 095.0404			
		CÓDIGO E.O.		ALTURA MÁXIMA	ALTURA MÍNIMA	DIÂMETRO MÁXIMO
		SCANIA	1.44.03.07	360 mm	185 mm	292 mm
		SCANIA	1.51.55.02			
				CÓDIGO DE REFERÊNCIA BOLSA COFAP BPC06205		
SCANIA K124 IB 4X2		EIXO DIANTEIRO				
MOLA CILÍNDRICA COFAP MPC06101	KIT PNEUMÁTICO COFAP KPC06103	CÓDIGO SIMILAR MOLA / BOLSA / KIT		TAMPA SUPERIOR	BASE	BATENTE
		GOODYEAR	556 0 2 8562 556 0 3 8065 556 0 2 8465	KTC06102	KBC06105	KBC06102
		FIRESTONE	(095.0482) 1T15MQX-3 095.0446			
		CÓDIGO E.O.		ALTURA MÁXIMA	ALTURA MÍNIMA	DIÂMETRO MÁXIMO
		SCANIA	1.44.03.01	335 mm	132 mm	350 mm
		SCANIA	1.51.54.99			
				CÓDIGO DE REFERÊNCIA BOLSA COFAP BPC06103		
SCANIA K124 IB 4X2		EIXO TRASEIRO				
MOLA CILÍNDRICA COFAP MPC06203	KIT PNEUMÁTICO COFAP KPC06203	CÓDIGO SIMILAR MOLA / BOLSA / KIT		TAMPA SUPERIOR	BASE	BATENTE
		GOODYEAR	556 0 2 8561 556 0 3 8063 556 0 2 8461	KTC06102	KBC06202	KBC06101
		FIRESTONE	(095.0481) 1T15LR-4 095.0416			
		CÓDIGO E.O.		ALTURA MÁXIMA	ALTURA MÍNIMA	DIÂMETRO MÁXIMO
		SCANIA	1.44.03.05	405 mm	219 mm	292 mm
		SCANIA	1.51.55.01			
				CÓDIGO DE REFERÊNCIA BOLSA COFAP BPC06203		

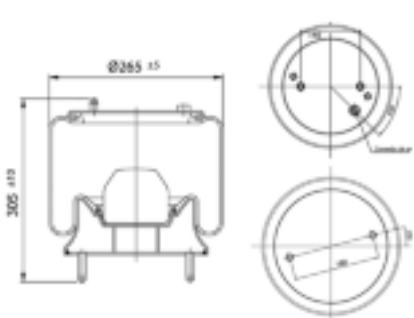
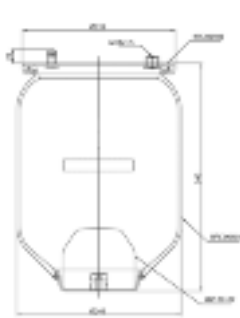
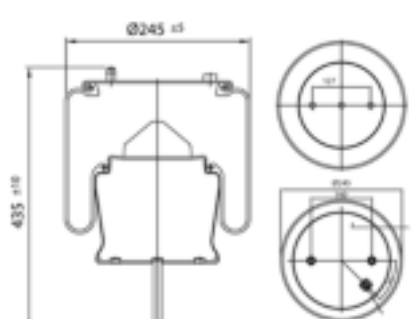
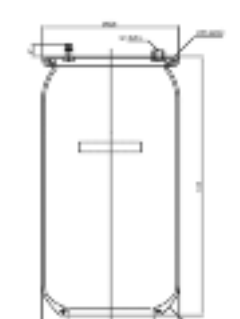
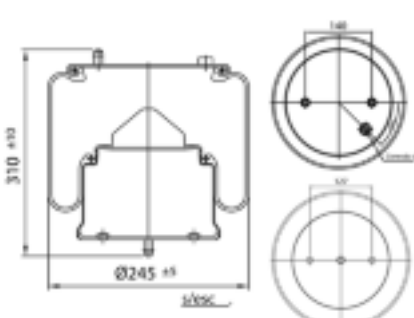
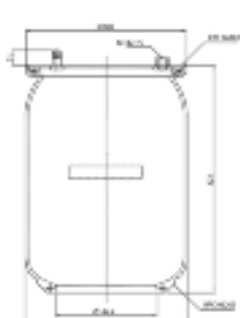

MOLA CILÍNDRICA E CONVOLUTADA

SCANIA KI24 IB 6X2		EIXO DIANTEIRO				
MOLA CILÍNDRICA COFAP MPC06101	KIT PNEUMÁTICO COFAP KPC06103	CÓDIGO SIMILAR MOLA / BOLSA / KIT		TAMPA SUPERIOR	BASE	BATENTE
		GOODYEAR	556 0 2 8562 556 0 3 8065 556 0 2 8465	KTC06102	KBC06105	KBC06102
		FIRESTONE	(095.0482) 1T15MQX-3 095.0446			
		CÓDIGO E.O.		ALTURA MÁXIMA	ALTURA MÍNIMA	DIÂMETRO MÁXIMO
		SCANIA	1.44.03.01	335 mm	132 mm	350 mm
SCANIA	1.51.54.99					
SCANIA	488.265	CÓDIGO DE REFERÊNCIA BOLSA COFAP BPC06103				
SCANIA KI24 IB 6X2		EIXO TRASEIRO				
MOLA CILÍNDRICA COFAP MPC06201	KIT PNEUMÁTICO COFAP KPC06203	CÓDIGO SIMILAR MOLA / BOLSA / KIT		TAMPA SUPERIOR	BASE	BATENTE
		GOODYEAR	556 0 2 8560 556 0 3 8063 556 0 2 8461	KTC06102	KBC06201	KBC06101
			(095.0481) 1T15L-4 095.0416			
		CÓDIGO E.O.		ALTURA MÁXIMA	ALTURA MÍNIMA	DIÂMETRO MÁXIMO
		SCANIA	1.44.03.04 1.44.03.06	405 mm	219 mm	292 mm
SCANIA	1.51.55.01					
SCANIA	470.922	CÓDIGO DE REFERÊNCIA BOLSA COFAP BPC06203				
SCANIA KI24 IB 6X2		TERCEIRO EIXO				
MOLA CILÍNDRICA COFAP MPC06202	KIT PNEUMÁTICO COFAP KPC06205	CÓDIGO SIMILAR MOLA / BOLSA / KIT		TAMPA SUPERIOR	BASE	BATENTE
		GOODYEAR	556 0 2 8563 556 0 3 8066 556 0 2 8463	KTC06102	KBC06203	KBC06101
		FIRESTONE	(095.0484) 1T15L-4 095.0404			
		CÓDIGO E.O.		ALTURA MÁXIMA	ALTURA MÍNIMA	DIÂMETRO MÁXIMO
		SCANIA	1.44.03.07	360 mm	185 mm	292 mm
SCANIA	1.51.55.02					
		CÓDIGO DE REFERÊNCIA BOLSA COFAP BPC06205				



Linha de produtos Cofap
MOLA PNEUMÁTICA PARA ÔNIBUS
 Mola cilíndrica e convolutada



MOLA CILÍNDRICA E CONVOLUTADA

SCANIA KI24 IB 8X2		EIXO TRASEIRO					
MOLA CILÍNDRICA COFAP MPC06201	KIT PNEUMÁTICO COFAP KPC06203	CÓDIGO SIMILAR MOLA / BOLSA / KIT		TAMPA SUPERIOR	BASE	BATENTE	
		GOODYEAR	556 0 2 8560 556 0 3 8063 556 0 2 8461	KTC06102	KBC06201	KBC06101	
		FIRESTONE	(095.0481) 1T15LR-4 095.0416				
		CÓDIGO E.O.		ALTURA MÁXIMA	ALTURA MÍNIMA	DIÂMETRO MÁXIMO	
		SCANIA	1.44.03.04 1.44.03.06	405 mm	219 mm	292 mm	
		SCANIA	1.51.55.01				
SCANIA	470.922	CÓDIGO DE REFERÊNCIA BOLSA COFAP BPC06203					
SCANIA KI24 IB 8X2		TERCEIRO EIXO					
MOLA CILÍNDRICA COFAP MPC06202	KIT PNEUMÁTICO COFAP KPC06205	CÓDIGO SIMILAR MOLA / BOLSA / KIT		TAMPA SUPERIOR	BASE	BATENTE	
		GOODYEAR	556 0 2 8563 556 0 3 8066 556 0 2 8463	KTC06102	KBC06203	KBC06101	
		FIRESTONE	(095.0405) / (095.0484) 1T15L-4 095.0404				
		CÓDIGO E.O.		ALTURA MÁXIMA	ALTURA MÍNIMA	DIÂMETRO MÁXIMO	
		SCANIA	1.44.03.07	360 mm	185 mm	292 mm	
		SCANIA	1.51.55.02				
		CÓDIGO DE REFERÊNCIA BOLSA COFAP BPC06205					
TUTTO		TERCEIRO EIXO					
MOLA CILÍNDRICA COFAP MPC99202	KIT PNEUMÁTICO COFAP KPC99202	CÓDIGO SIMILAR MOLA / BOLSA / KIT		TAMPA SUPERIOR	BASE	BATENTE	
		GOODYEAR	556 0 2 8774 556 0 3 8088 556 0 2 8675	KTC06102	KBC06107	KBC06101	
		CÓDIGO E.O.					ALTURA MÁXIMA
				445 mm	182 mm	320 mm	
				CÓDIGO DE REFERÊNCIA BOLSA COFAP BPC99202			

linha de
produtos



mola pneumática para ônibus

bolsa cilíndrica
e convolutada

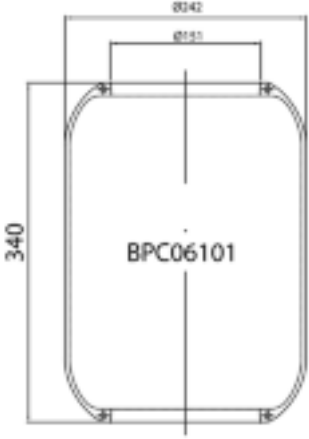
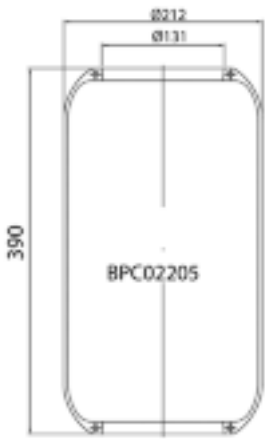
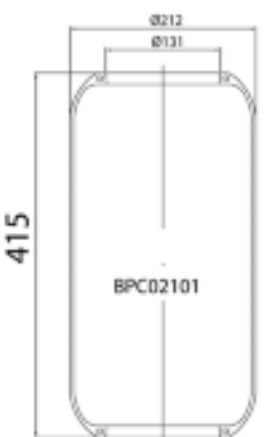

BOLSA CILÍNDRICA E CONVOLUTADA

MAFERSA M210	EIXO DIANTEIRO / EIXO TRASEIRO	
BOLSA CILÍNDRICA COFAP BPC06101	CÓDIGO SIMILAR	
	GOODYEAR	556 0 3 8019
	FIRESTONE	1R1E-335-320 (095.0134)
	CÓDIGO E.O.	
	SCANIA	1.673.407
	SCANIA	523.208
	SCANIA	520.243
	CÓDIGO E.O.	
MERCEDES-BENZ O-370 / O-371 / O-400	EIXO DIANTEIRO / EIXO TRASEIRO / 3º EIXO	
BOLSA CILÍNDRICA COFAP BPC02205	CÓDIGO SIMILAR	
	GOODYEAR	556 0 3 8017
	FIRESTONE	1R1A-390-295 (095.0118)
	CÓDIGO E.O.	
	MERCEDES-BENZ	A 364.327.7001
	MERCEDES-BENZ	A 364.327.7101
	MERCEDES-BENZ	A 364.327.7301
	CÓDIGO E.O.	
MERCEDES-BENZ O-500 M / O-500 R / O-500 RS	EIXO DIANTEIRO	
BOLSA CILÍNDRICA COFAP BPC02101	CÓDIGO SIMILAR	
	GOODYEAR	556 0 3 8013
	FIRESTONE	1R1A-415-285 (095.0197)
	CÓDIGO E.O.	
	MERCEDES-BENZ	A 328.327.7201
	MERCEDES-BENZ	A 328.327.7301
	CÓDIGO E.O.	



Linha de produtos Cofap
MOLA PNEUMÁTICA PARA ÔNIBUS
 Bolsa cilíndrica e convolutada





BOLSA CILÍNDRICA E CONVOLUTADA

MERCEDES-BENZ O-500 M / O-500 R / O-500 R5	EIXO TRASEIRO / 3º EIXO	
BOLSA CILÍNDRICA COFAP BPC02205	CÓDIGO SIMILAR	
	GOODYEAR	556 0 3 8017
	FIRESTONE	1R1A-390-295 (095.0118)
	CÓDIGO E.O.	
	MERCEDES-BENZ	A 364.327.7001
	MERCEDES-BENZ	A 364.327.7101
	MERCEDES-BENZ	A 364.327.7301
MERCEDES-BENZ O-500 RSD	3º EIXO	
BOLSA CILÍNDRICA COFAP BPC02204	CÓDIGO SIMILAR	
	GOODYEAR	556 0 3 8099
	FIRESTONE	1R1A-415-315 (095.0553)
	CÓDIGO E.O.	
	MERCEDES-BENZ	A 634.327.0001
	CÓDIGO SIMILAR	
	CÓDIGO E.O.	
MERCEDES-BENZ O-500 U	EIXO DIANTEIRO / EIXO TRASEIRO / 3º EIXO	
BOLSA CILÍNDRICA COFAP BPC02205	CÓDIGO SIMILAR	
	GOODYEAR	556 0 3 8017
	FIRESTONE	1R1A-390-295 (095.0118)
	CÓDIGO E.O.	
	MERCEDES-BENZ	A 364.327.7001
	MERCEDES-BENZ	A 364.327.7101
	MERCEDES-BENZ	A 364.327.7301

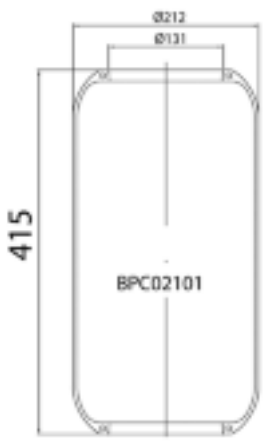

BOLSA CILÍNDRICA E CONVOLUTADA

MERCEDES-BENZ OH 14 TONELADAS	EIXO DIANTEIRO	
BOLSA CILÍNDRICA COFAP BPC02101	CÓDIGO SIMILAR	
	GOODYEAR	556 0 3 8013
	FIRESTONE	1R1A-415-285 (095.0197)
	CÓDIGO E.O.	
	MERCEDES-BENZ	A 382.327.7201
	MERCEDES-BENZ	A 382.327.7301
MERCEDES-BENZ OH 14 TONELADAS	EIXO TRASEIRO	
BOLSA CILÍNDRICA COFAP BPC02201	CÓDIGO SIMILAR	
	GOODYEAR	556 0 3 8031
	FIRESTONE	1R2D-460-360 (095.0191)
	CÓDIGO E.O.	
	MERCEDES-BENZ	A 382.327.7001
	MERCEDES-BENZ OH 16 TONELADAS	EIXO DIANTEIRO
BOLSA CILÍNDRICA COFAP BPC02101	CÓDIGO SIMILAR	
	GOODYEAR	556 0 3 8013
	FIRESTONE	1R1A-415-285 (095.0197)
	CÓDIGO E.O.	
	MERCEDES-BENZ	A 382.327.7201
	MERCEDES-BENZ	A 382.327.7301



Linha de produtos Cofap
MOLA PNEUMÁTICA PARA ÔNIBUS
 Bolsa cilíndrica e convolutada





BOLSA CILÍNDRICA E CONVOLUTADA

MERCEDES-BENZ OH 16 TONELADAS	EIXO TRASEIRO	
BOLSA CILÍNDRICA COFAP BPC02201	CÓDIGO SIMILAR	
	GOODYEAR	556 0 3 8031
	FIRESTONE	1R2D-460-360 (095.0191)
	CÓDIGO E.O.	
	MERCEDES-BENZ	A 382.327.7001
MERCEDES-BENZ OH 16 TONELADAS	EIXO TRASEIRO	
BOLSA CILÍNDRICA COFAP BPC02202	CÓDIGO SIMILAR	
	GOODYEAR	556 0 3 8030
	FIRESTONE	1R2D-460-360 (095.0191)
	CÓDIGO E.O.	
	MERCEDES-BENZ	A 382.327.0001
MERCEDES-BENZ OH 16 TONELADAS	EIXO TRASEIRO	
BOLSA CILÍNDRICA COFAP BPC02203	CÓDIGO SIMILAR	
	GOODYEAR	556 0 3 8317
	FIRESTONE	1R2D-460-360 (095.0191)
	CÓDIGO E.O.	
	MERCEDES-BENZ	A 382.327.0101
MERCEDES-BENZ	A 382.327.7501	

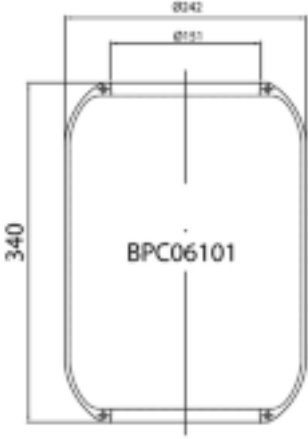
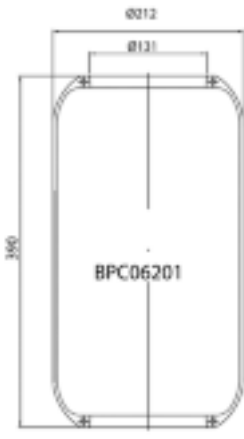

BOLSA CILÍNDRICA E CONVOLUTADA

<p>SCANIA K112 / K113</p>	<p>EIXO DIANTEIRO</p>	
<p>BOLSA CILÍNDRICA COFAP BPC06101</p>	<p>CÓDIGO SIMILAR</p>	
	<p>GOODYEAR</p>	<p>556 0 3 8019</p>
	<p>FIRESTONE</p>	<p>1R1E-335-320 (095.0134)</p>
	<p>CÓDIGO E.O.</p>	
	<p>SCANIA</p>	<p>1.673.407 523.208 520.243</p>
<p>SCANIA K112</p>	<p>EIXO TRASEIRO / 3º EIXO</p>	
<p>BOLSA CILÍNDRICA COFAP BPC06201</p>	<p>CÓDIGO SIMILAR</p>	
	<p>GOODYEAR</p>	<p>556 0 3 8016</p>
	<p>FIRESTONE</p>	<p>1R1B-390-270 (095.0121)</p>
	<p>CÓDIGO E.O.</p>	
	<p>SCANIA</p>	<p>1.673.412 523.229 533.802</p>
<p>SCANIA K113</p>	<p>EIXO TRASEIRO</p>	
<p>BOLSA CILÍNDRICA COFAP BPC06201</p>	<p>CÓDIGO SIMILAR</p>	
	<p>GOODYEAR</p>	<p>556 0 3 8016</p>
	<p>FIRESTONE</p>	<p>1R1B-390-270 (095.0121)</p>
	<p>CÓDIGO E.O.</p>	
	<p>SCANIA</p>	<p>1.673.412 523.229 533.802</p>



Linha de produtos Cofap
MOLA PNEUMÁTICA PARA ÔNIBUS
 Bolsa cilíndrica e convolutada



BOLSA CILÍNDRICA E CONVOLUTADA

<p>SCANIA KI13 LILIKLAS</p>	<p>EIXO DIANTEIRO</p>	
<p>BOLSA CILÍNDRICA COFAP BPC06102</p>	<p>CÓDIGO SIMILAR</p>	
	<p>GOODYEAR</p>	<p>556 0 3 8028</p>
	<p>FIRESTONE</p>	<p>1R1K-440-320 (095.0229)</p>
	<p>CÓDIGO E.O.</p>	
	<p>SCANIA</p>	<p>411.623</p>
<p>SCANIA KI13 LILIKLAS</p>	<p>EIXO TRASEIRO / 3º EIXO</p>	
<p>BOLSA CILÍNDRICA COFAP BPC06202</p>	<p>CÓDIGO SIMILAR</p>	
	<p>GOODYEAR</p>	<p>556 0 3 8037</p>
	<p>FIRESTONE</p>	<p>1R1J-415-285 (095.0244)</p>
	<p>CÓDIGO E.O.</p>	
	<p>SCANIA</p>	<p>434.932</p>
<p>VOLKSWAGEN 17.240 (até 2001)</p>	<p>EIXO DIANTEIRO</p>	
<p>BOLSA CILÍNDRICA COFAP BPC01102</p>	<p>CÓDIGO SIMILAR</p>	
	<p>GOODYEAR</p>	<p>556 0 3 8042</p>
	<p>FIRESTONE</p>	<p>1R1K-380-320 (095.0228)</p>
	<p>CÓDIGO E.O.</p>	
	<p>VW BUS</p>	<p>2TB 411 099 (até 2001)</p>



Linha de produtos Cofap
MOLA PNEUMÁTICA PARA ÔNIBUS
 Bolsa cilíndrica e convolutada



BOLSA CILÍNDRICA E CONVOLUTADA

<p>VOLKSWAGEN 17.240 OT / 17.260 EOT / 18.320 EOT</p>	<p>EIXO DIANTEIRO</p>	
<p>BOLSA CILÍNDRICA COFAP BPC01101</p>	<p>CÓDIGO SIMILAR</p>	
	<p>GOODYEAR</p>	<p>556 0 3 8072</p>
	<p>FIRESTONE</p>	<p>1R1K-330-320 (095.0427)</p>
	<p>CÓDIGO E.O.</p>	
	<p>VW BUS</p>	<p>2Z0 616 041A</p>
<p>VOLKSWAGEN 17.240 OT / 17.260 EOT / 18.320 EOT</p>	<p>EIXO TRASEIRO</p>	
<p>BOLSA CILÍNDRICA COFAP BPC01201</p>	<p>CÓDIGO SIMILAR</p>	
	<p>GOODYEAR</p>	<p>556 0 3 8313</p>
	<p>FIRESTONE</p>	<p>1R1E-440-320 (095.0375)</p>
	<p>CÓDIGO E.O.</p>	
	<p>VW BUS</p>	<p>2TB 511 101A</p>
<p>VW BUS</p>	<p>2TB 511 383</p>	
<p>VOLVO B7 / BIO / BI2</p>	<p>EIXO DIANTEIRO</p>	
<p>BOLSA CILÍNDRICA COFAP BPC19101</p>	<p>CÓDIGO SIMILAR</p>	
	<p>GOODYEAR</p>	<p>556 0 3 8018</p>
	<p>FIRESTONE</p>	<p>1R1C-390-310 (095.0021)</p>
	<p>CÓDIGO E.O.</p>	
	<p>VOLVO</p>	<p>1.137.882</p>
<p>VOLVO</p>	<p>1.137.888</p>	
<p>VOLVO</p>	<p>1.593.842 3.159.253</p>	

* imagens meramente Ilustrativas



Linha de produtos Cofap
MOLA PNEUMÁTICA PARA ÔNIBUS
 Bolsa cilíndrica e convolutada



BOLSA CILÍNDRICA E CONVOLUTADA

VOLVO B7 / BIO / BI2	EIXO TRASEIRO / 3º EIXO	
BOLSA CILÍNDRICA COFAP BPC02205	CÓDIGO SIMILAR	
	GOODYEAR	556 0 3 8017
	FIRESTONE	1R1A-390-295 (095.0118)
	CÓDIGO E.O.	
	VOLVO	1.134.445
	VOLVO	1.199.873
VOLVO	1.622.111 3.159.252	
VOLVO BIOB	EIXO DIANTEIRO / EIXO TRASEIRO	
BOLSA CILÍNDRICA COFAP BPC19103	CÓDIGO SIMILAR	
	GOODYEAR	556 0 3 8922
	FIRESTONE	1R5P-410-290 (095.0382)
	CÓDIGO E.O.	
	VOLVO	3.027.272
VOLVO BIOM MK4	EIXO DIANTEIRO	
BOLSA CILÍNDRICA COFAP BPC19104	CÓDIGO SIMILAR	
	GOODYEAR	556 0 3 8911
	FIRESTONE	1R5P-345-290 (095.0381)
	CÓDIGO E.O.	
	VOLVO	3.027.271

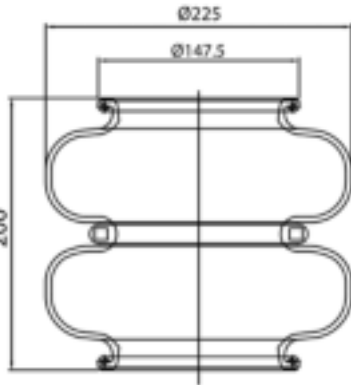

BOLSA CILÍNDRICA E CONVOLUTADA

<p>VOLVO BIOM MK4</p>	<p>EIXO TRASEIRO</p>	
<p>BOLSA CILÍNDRICA COFAP BPC19103</p>	<p>CÓDIGO SIMILAR</p>	
	<p>GOODYEAR</p>	<p>556 0 3 8922</p>
	<p>FIRESTONE</p>	<p>1R5P-410-290 (095.0382)</p>
	<p>CÓDIGO E.O.</p>	
	<p>VOLVO</p>	<p>3.027.272</p>
<p>VOLVO B58</p>	<p>EIXO DIANTEIRO / EIXO TRASEIRO</p>	
<p>BOLSA CONVOLUTADA COFAP BPC19102</p>	<p>CÓDIGO SIMILAR</p>	
	<p>GOODYEAR</p>	<p>556 2 3 8325</p>
	<p>FIRESTONE</p>	<p>20 (095.0009)</p>
	<p>CÓDIGO E.O.</p>	
	<p>VOLVO</p>	<p>1.199.733</p>
<p>VOLVO</p>	<p>8.127.151</p>	
<p>VOLVO</p>	<p>355.461</p>	

linha de
produtos



mola pneumática
para ônibus
kit pneumático



KIT PNEUMÁTICO

mola pneumática - kit

40

KIT PNEUMÁTICO COFAP KPC06103	BOLSA PNEUMÁTICA COFAP BPC06103	CÓDIGO SIMILAR KIT / BOLSA		TAMPA SUPERIOR	TAMPA INFERIOR	BATENTE
		GOODYEAR	556 0 2 8465 556 0 3 8065	KTC06102	-	KBC06102
		FIRESTONE	095.0446 1T15MQX-3			
		CÓDIGO E.O.				
		SCANIA	1.44.03.01			
		SCANIA	1.51.54.99			
		SCANIA	488.265			

KIT PNEUMÁTICO COFAP KPC06104	BOLSA PNEUMÁTICA COFAP BPC06104	CÓDIGO SIMILAR KIT / BOLSA		TAMPA SUPERIOR	TAMPA INFERIOR	BATENTE
		GOODYEAR	556 0 2 8460 556 0 3 8067	KTC06102		
		FIRESTONE	095.0431 1T15L-4			
		CÓDIGO E.O.				
		SCANIA	1.44.03.03			
		SCANIA	1.47.51.06			
		SCANIA	488.263			

KIT PNEUMÁTICO COFAP KPC06105	BOLSA PNEUMÁTICA COFAP BPC06105	CÓDIGO SIMILAR KIT / BOLSA		TAMPA SUPERIOR	TAMPA INFERIOR	BATENTE
		GOODYEAR	556 0 2 8464 556 0 3 8068	KTC06102	-	KBC99102
		FIRESTONE	095.0446 1T15MQX-3			
		CÓDIGO E.O.				
		SCANIA	1.15.14.99			
		SCANIA	1.44.03.02			
		SCANIA	488.266			



Linha de produtos Cofap
MOLA PNEUMÁTICA PARA ÔNIBUS
 Kit Pneumático



KIT PNEUMÁTICO

KIT PNEUMÁTICO COFAP KPC06203	BOLSA PNEUMÁTICA COFAP BPC06203	CÓDIGO SIMILAR KIT / BOLSA		TAMPA SUPERIOR	TAMPA INFERIOR	BATENTE
		GOODYEAR	556 0 2 8461 556 0 3 8063	KTC06102		
		FIRESTONE	095.0416 1T15LR-4			
		CÓDIGO E.O.		ALTURA MÁXIMA	ALTURA MÍNIMA	DIÂMETRO MÁXIMO
		SCANIA	1.44.03.04 1.44.03.05 1.44.03.06			
		SCANIA	1.51.55.01			
		SCANIA	470.922			
KIT PNEUMÁTICO COFAP KPC06205	BOLSA PNEUMÁTICA COFAP BPC06205	CÓDIGO SIMILAR KIT / BOLSA		TAMPA SUPERIOR	TAMPA INFERIOR	BATENTE
		GOODYEAR	556 0 2 8463 556 0 3 8066	KTC06102		
		FIRESTONE	095.0404 1T15L-4			
		CÓDIGO E.O.		ALTURA MÁXIMA	ALTURA MÍNIMA	DIÂMETRO MÁXIMO
		SCANIA	1.44.03.07			
		SCANIA	1.51.55.02			
KIT PNEUMÁTICO COFAP KPC06206	BOLSA PNEUMÁTICA COFAP BPC06206	CÓDIGO SIMILAR KIT / BOLSA		TAMPA SUPERIOR	TAMPA INFERIOR	BATENTE
		GOODYEAR	556 0 2 8462 556 0 3 8069	KTC06102		
		FIRESTONE	095.0416 1T15LR-4			
		CÓDIGO E.O.		ALTURA MÁXIMA	ALTURA MÍNIMA	DIÂMETRO MÁXIMO
		SCANIA	1.44.03.06			
		SCANIA	1.51.55.01			

mola pneumática - kit

* imagens meramente ilustrativas



KIT PNEUMÁTICO

KIT PNEUMÁTICO COFAP KPC99202	BOLSA PNEUMÁTICA COFAP BPC99202	CÓDIGO SIMILAR KIT / BOLSA		TAMPA SUPERIOR	TAMPA INFERIOR	BATENTE
		GOODYEAR	556 0 2 8675 556 0 3 8088	KTC99202	-	KBC99202
		CÓDIGO E.O.				

mola pneumática - kit

42

linha de
produtos



mola pneumática
para caminhões e carretas
mola cilíndrica
e convolutada

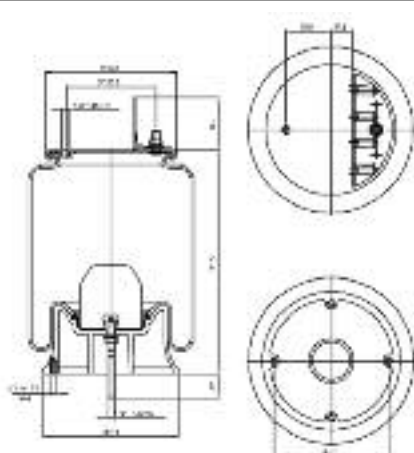

MOLA CILÍNDRICA E CONVOLUTADA

INTERNATIONAL 9200 / 9800	EIXO TRASEIROEIXO TRASEIRO / TERCEIRO EIXO				
MOLA CILÍNDRICA COFAP MPC99203	CÓDIGO SIMILAR MOLA / BOLSA / KIT	TAMPA SUPERIOR	BASE	BATENTE	
	GOODYEAR	556 0 2 8727	KTC99209	KBC99206	KBC99215
	FIRESTONE	(095.0356) 1T15MT-8			
	CÓDIGO E.O.		ALTURA MÁXIMA	ALTURA MÍNIMA	DIÂMETRO MÁXIMO
	INTERNATIONAL	2036090C1	555 mm	190 mm	320 mm
CÓDIGO DE REFERÊNCIA BOLSA COFAP BPC99213					

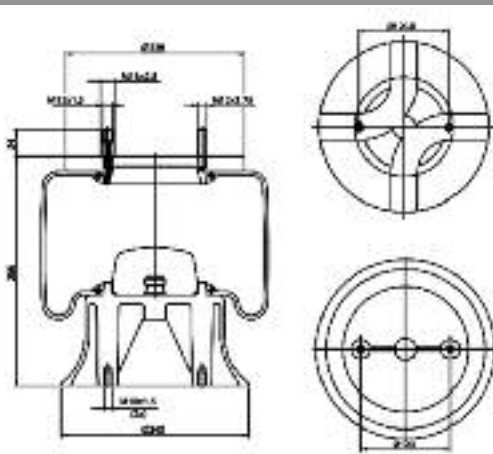
PULVERIZADOR JACTO					
MOLA CILÍNDRICA COFAP MPC99204	CÓDIGO SIMILAR MOLA / BOLSA / KIT	TAMPA SUPERIOR	TAMPA INFERIOR	BATENTE	
	GOODYEAR	556 0 2 8711	KTC99211	KBC99211	KBC99212
	CÓDIGO E.O.				
			400 mm	190 mm	280 mm
	CÓDIGO DE REFERÊNCIA BOLSA COFAP BPC99214				

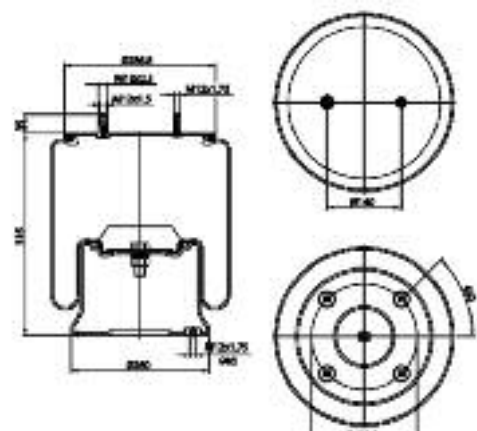
CARRETAS					
MOLA CILÍNDRICA COFAP MPC99205	CÓDIGO SIMILAR MOLA / BOLSA / KIT	TAMPA SUPERIOR	BASE	BATENTE	
	GOODYEAR	556 0 2 8550	KTC99201	KBC99204	KBC99214
	FIRESTONE	(095.0320) 1T19L-11			
	CÓDIGO E.O.		ALTURA MÁXIMA	ALTURA MÍNIMA	DIÂMETRO MÁXIMO
	NOMA	9 200 164	655 mm	212 mm	360 mm
	RANDON / SUSPENYS	212 100 261			
CÓDIGO DE REFERÊNCIA BOLSA COFAP BPC99211					

* imagens meramente ilustrativas



Linha de produtos Cofap
MOLA PNEUMÁTICA PARA CAMINHÕES E CARRETAS
 Mola cilíndrica e convolutada



MOLA CILÍNDRICA E CONVOLUTADA

CARRETAS	EIXO TRASEIRO				
MOLA CILÍNDRICA COFAP MPC99206	CÓDIGO SIMILAR MOLA / BOLSA / KIT	TAMPA SUPERIOR	BASE	BATENTE	
	GOODYEAR	556 0 2 8691	KTC99210	KBC99204	KBC99214
		(095.0378) 1T19F-11			
	CÓDIGO E.O.		ALTURA MÁXIMA	ALTURA MÍNIMA	DIÂMETRO MÁXIMO
			655 mm	212 mm	360 mm
	CÓDIGO DE REFERÊNCIA BOLSA COFAP BPC99211				
CARRETAS	EIXO TRASEIRO				
MOLA CILÍNDRICA COFAP MPC99207	CÓDIGO SIMILAR MOLA / BOLSA / KIT	TAMPA SUPERIOR	BASE	BATENTE	
	GOODYEAR	556 0 2 8406	KTC99203	KBC99208	
	FIRESTONE	20-2 T.3			
	CÓDIGO E.O.		ALTURA MÁXIMA	ALTURA MÍNIMA	DIÂMETRO MÁXIMO
	HBZ	80006-07	275 mm	76 mm	265 mm
SILPA	2.210.200.160				
	CÓDIGO DE REFERÊNCIA BOLSA COFAP BPC99210				
CARRETAS	EIXO TRASEIRO				
MOLA CONVULTADA COFAP MPC99208	CÓDIGO SIMILAR MOLA / BOLSA / KIT	TAMPA SUPERIOR	BASE	BATENTE	
	GOODYEAR	556 0 2 8666	KTC99208	KBC99205	KBC99215
	FIRESTONE	(095.0314) 1T15M-9			
	CÓDIGO E.O.		ALTURA MÁXIMA	ALTURA MÍNIMA	DIÂMETRO MÁXIMO
	FACCHINI	308 501 705	600 mm	220 mm	320 mm
	HBZ	80006-03			
RANDON	212 100 301	CÓDIGO DE REFERÊNCIA BOLSA COFAP BPC99213			

* imagens meramente ilustrativas

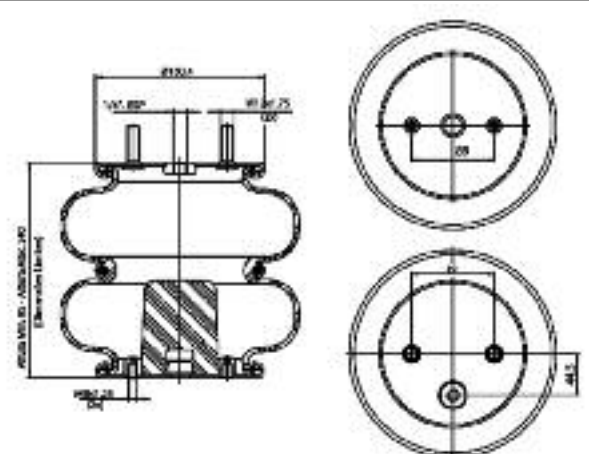
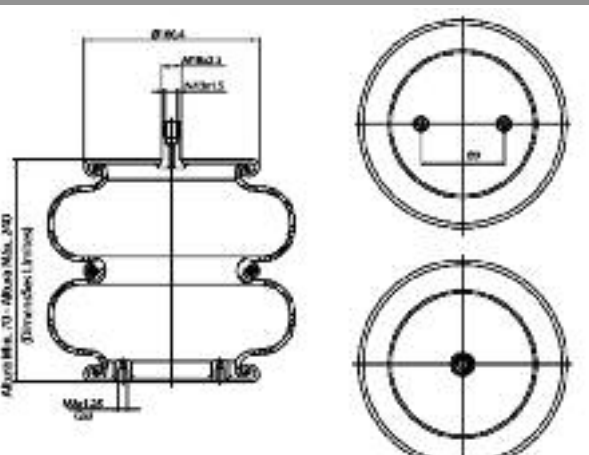
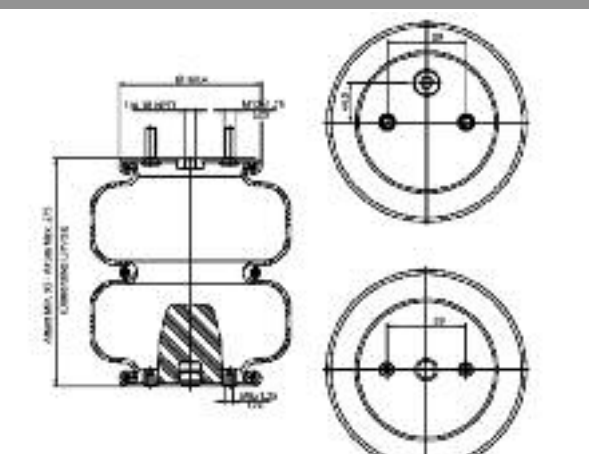

MOLA CILÍNDRICA E CONVOLUTADA

CARRETAS	LEVANTE DO EIXO				
MOLA CONVULTADA COFAP MPC99210	CÓDIGO SIMILAR MOLA / BOLSA / KIT	TAMPA SUPERIOR	BASE	BATENTE	
	GOODYEAR	556 0 2 8521	KTC99205	KBC99210	
	FIRESTONE	(095.0313) 20			KBC99213
	CÓDIGO E.O.		ALTURA MÁXIMA	ALTURA MÍNIMA	
	JOST	AD00076J00	240 mm	95 mm	250 mm
			CÓDIGO DE REFERÊNCIA BOLSA COFAP BPC19102		
CARRETAS / VOLVO NH12 / FH12	LEVANTE DO EIXO				
MOLA CONVULTADA COFAP MPC99211	CÓDIGO SIMILAR MOLA / BOLSA / KIT	TAMPA SUPERIOR	BASE	BATENTE	
	GOODYEAR	556 0 2 8520	KTC99204	KBC99208	
	FIRESTONE	(095.0353) 20			KBC99213
	CÓDIGO E.O.		ALTURA MÁXIMA	ALTURA MÍNIMA	
	GUERRA	5.036.002.015.006	240 mm	76 mm	250 mm
	RANDON	212 100 278	CÓDIGO DE REFERÊNCIA BOLSA COFAP BPC19102		
VOLVO	212 100 278				
CARRETAS	LEVANTE DE EIXO / TERCEIRO EIXO				
MOLA CONVULTADA COFAP MPC99216	CÓDIGO SIMILAR MOLA / BOLSA / KIT	TAMPA SUPERIOR	BASE	BATENTE	
	GOODYEAR	556 0 2 8657	KTC99205	KBC99213	
	FIRESTONE	(095.0327) 20-2			KBC99213
	CÓDIGO E.O.		ALTURA MÁXIMA	ALTURA MÍNIMA	
	FACCHINI	308 501 713	275 mm	95 mm	265 mm
			CÓDIGO DE REFERÊNCIA BOLSA COFAP BPC99210		

* imagens meramente ilustrativas



Linha de produtos Cofap
MOLA PNEUMÁTICA PARA CAMINHÕES E CARRETAS
 Mola cilíndrica e convolutada

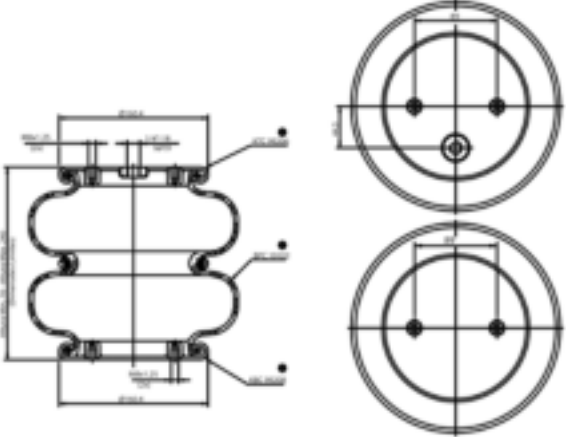

MOLA CILÍNDRICA E CONVOLUTADA

CARRETAS	EIXO TRASEIRO				
MOLA CONVULTADA COFAP MPC99219	CÓDIGO SIMILAR MOLA / BOLSA / KIT		TAMPA SUPERIOR	BASE	BATENTE
	GOODYEAR	556 0 2 8649	KTC99206	KBC99208	-
	FIRESTONE	(095.0255) 20			
	CÓDIGO E.O.		ALTURA MÁXIMA	ALTURA MÍNIMA	DIÂMETRO MÁXIMO
	NOMA	9 200 165	240 mm	76 mm	250 mm
	RANDON	218 004 237	CÓDIGO DE REFERÊNCIA BOLSA COFAP BPC19102		

linha de
produtos



mola pneumática
para caminhões e carretas
bolsa cilíndrica
e convolutada

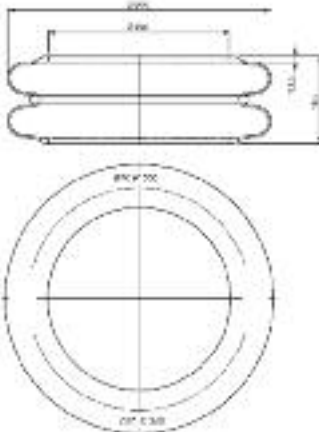
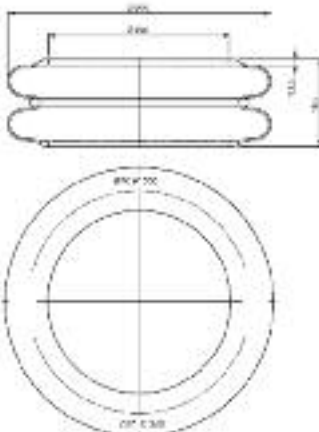
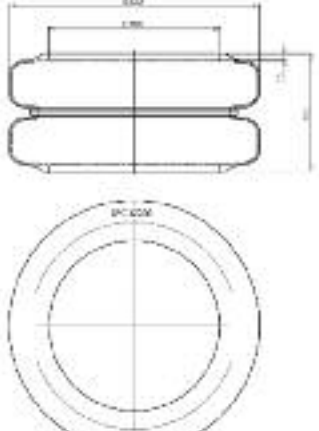

BOLSA CILÍNDRICA E CONVOLUTADA

CARRETAS	LEVANTE DE EIXO
BOLSA CONVOLUTADA COFAP BPC01202	CÓDIGO SIMILAR
	GOODYEAR 556 2 3 8034
	FIRESTONE 290
	CÓDIGO E.O.
	JOST AD00100
	RANDON 260 000 234
	UNIFERRO 02012100
CAMINHÕES VOLKSWAGEN 24.250 E WORKER / 24.250 CONSTELLATION / 25.370 CONSTELLATION	LEVANTE DE EIXO
BOLSA CONVOLUTADA COFAP BPC01202	CÓDIGO SIMILAR
	GOODYEAR 556 2 3 8034
	FIRESTONE 290
	CÓDIGO E.O.
	JOST AD00100
	RANDON 260000234
	UNIFERRO 02012100
MERCEDES-BENZ I620 TRUCK	LEVANTE DE EIXO
BOLSA CONVOLUTADA COFAP BPC02206	CÓDIGO SIMILAR
	GOODYEAR 556 2 3 8077
	CÓDIGO E.O.
	JOST AD00115
	MERCEDES-BENZ A 695 327 00 01



Linha de produtos Cofap
MOLA PNEUMÁTICA PARA CAMINHÕES E CARRETAS
 Bolsa cilíndrica e convolutada



BOLSA CILÍNDRICA E CONVOLUTADA

CARRETAS	LEVANTE DE EIXO	
BOLSA CONVOLUTADA COFAP BPC99203	CÓDIGO SIMILAR	
	GOODYEAR	556 2 3 8064
	CÓDIGO E.O.	
CARRETAS	LEVANTE DE EIXO	
BOLSA CONVOLUTADA COFAP BPC99204	CÓDIGO SIMILAR	
	GOODYEAR	556 2 2 8083
	CÓDIGO E.O.	
	JUST	AD00135
	RANDON	260000552
	SILPA	2210200184
	UNIFERRO	29060002
CARRETAS	LEVANTE DE EIXO	
BOLSA CONVOLUTADA COFAP BPC99205	CÓDIGO SIMILAR	
	GOODYEAR	556 2 3 8203
	FIRESTONE	203 (095.0358)
	CÓDIGO E.O.	
	RANDON	212007153
	RECRUSUL	10079887
	SILPA	2210200015
	UNIFERRO	02012400



Linha de produtos Cofap
 MOLA PNEUMÁTICA PARA CAMINHÕES E CARRETAS
 Bolsa cilíndrica e convolutada



BOLSA CILÍNDRICA E CONVOLUTADA

CARRETAS

LEVANTE DE EIXO

BOLSA CONVOLUTADA COFAP
 BPC99206

CÓDIGO SIMILAR



GOODYEAR

556 2 3 8350

FIRESTONE

29 (095.0250)

CÓDIGO E.O.

RANDON

212007152

RECRUSUL

10079904

SILPA

2210200003

UNIFERRO

02011700

linha de
produtos



mola pneumática
para caminhões, carretas e ônibus
componentes:
batente



COMPONENTES - MÓDULO BATENTE

BATENTE DIANTEIRO

KBC02101 BATENTE DIANTEIRO (aplicado com a bolsa BPC02205)
MERCEDES-BENZ - ônibus O-370/ O-371/ O-400/ O-500

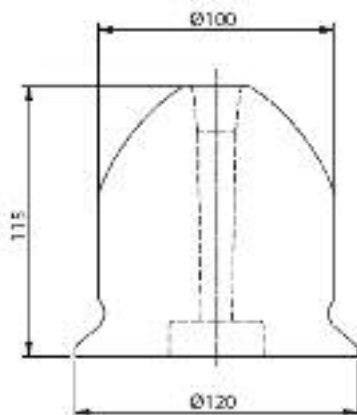

CÓDIGO SIMILAR

GOODYEAR

HT-3010

CÓDIGO E.O.

MERCEDES-BENZ

364 321 00 06

BATENTE DIANTEIRO

KBC02102 BATENTE TRASEIRO (aplicado com a bolsa BPC02205)
MERCEDES-BENZ - ônibus O-370/ O-371/ O-400/ O-500

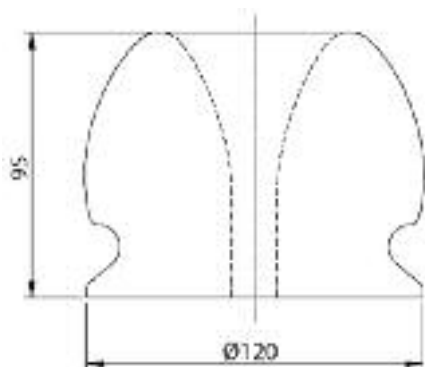

CÓDIGO SIMILAR

GOODYEAR

HT-3011

CÓDIGO E.O.

MERCEDES-BENZ

305 324 01 08

linha de
produtos



mola pneumática
para caminhões, carretas e ônibus
componentes:
tampa



COMPONENTES - MÓDULO TAMPA

TAMPA DIANTEIRA

TAMPA COFAP
KBC06111

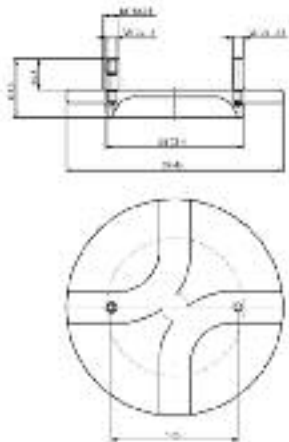

CÓDIGO SIMILAR

GOODYEAR

HT-5009

CÓDIGO E.O.

SCANIA K-112

520242

SCANIA K-112

1673408

TAMPA TRASEIRA

TAMPA COFAP
KBC06209

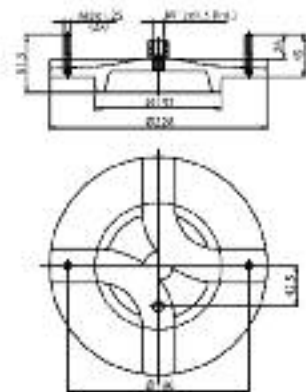

CÓDIGO SIMILAR

GOODYEAR

HT-5028

CÓDIGO E.O.

SCANIA

1673413

SCANIA

539995

linha de
produtos



mola pneumática
para caminhões, carretas e ônibus
componentes:
base



COMPONENTES - MÓDULO BASE

BASE DIANTEIRA

BASE COFAP
KBC02103

CÓDIGO SIMILAR

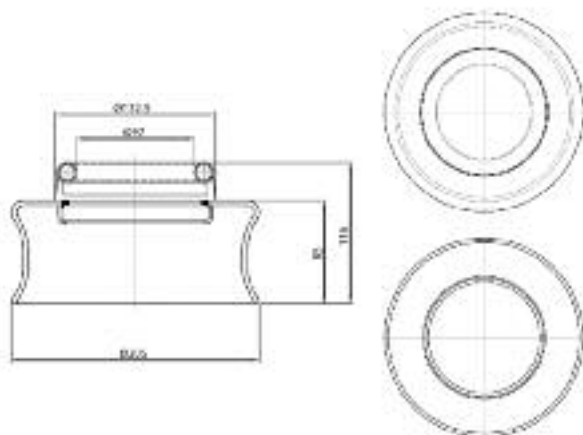

CÓDIGO E.O.

MERCEDES-BENZ

364 321 00 06

MERCEDES-BENZ

307 320 01 75

BASE TRASEIRA

BASE COFAP
KBC02201

CÓDIGO SIMILAR

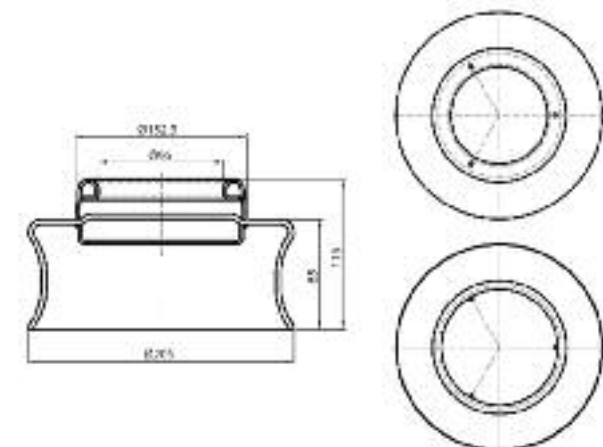

GOODYEAR

HT-5055

CÓDIGO E.O.

MERCEDES-BENZ

364 320 70 34

MERCEDES-BENZ

357 320 01 34

MERCEDES-BENZ

634 320 37 34

BASE TERCEIRO EIXO

BASE COFAP
KBC02202

CÓDIGO SIMILAR

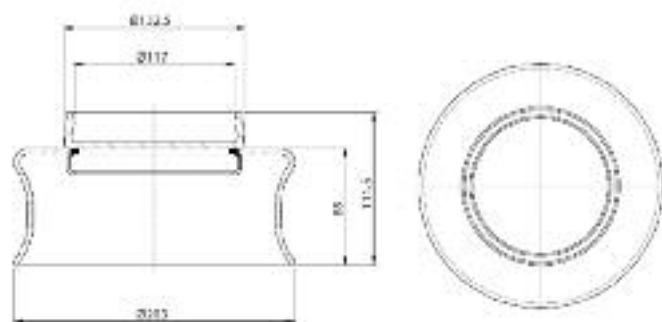

CÓDIGO E.O.

MERCEDES-BENZ

634 320 38 34



Linha de produtos Cofap
 MOLA PNEUMÁTICA
 Componentes - Base



COMPONENTES - MÓDULO BASE

BASE DIANTEIRA

**BASE COFAP
 KBC06104**

CÓDIGO SIMILAR

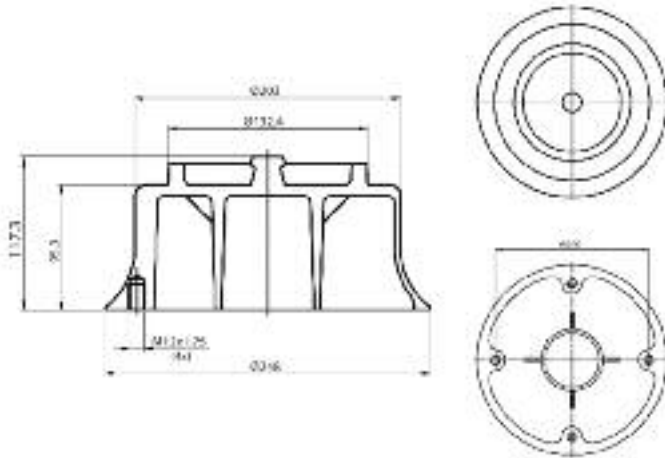

GOODYEAR

HT-5001

CÓDIGO E.O.

SCANIA

520244

BASE DIANTEIRA COM BATENTE

**CONJUNTO BASE + BATENTE COFAP
 KBC06108**

CÓDIGO SIMILAR

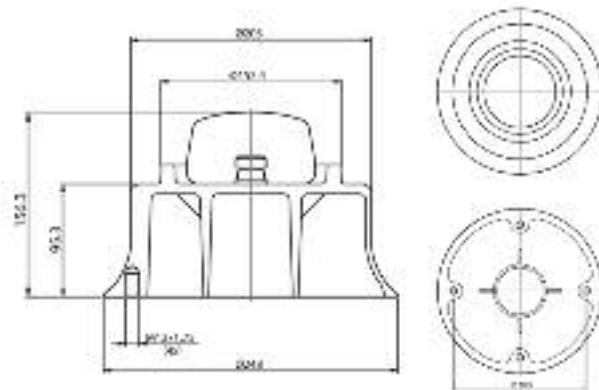

GOODYEAR

HT-5008

CÓDIGO E.O.

SCANIA

1673409

SCANIA

520244

BASE DIANTEIRA

**BASE COFAP
 KBC06109**

CÓDIGO SIMILAR

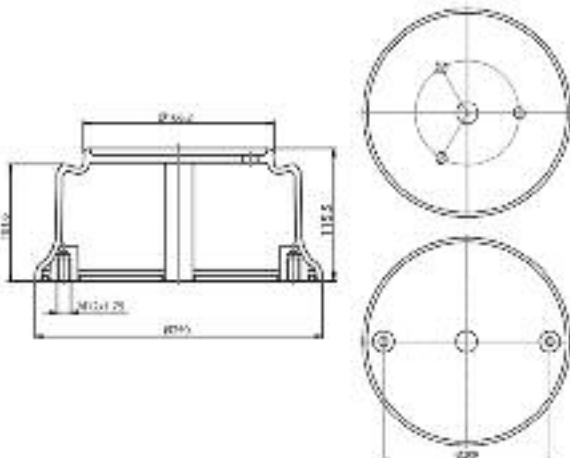

GOODYEAR

HT-5067

CÓDIGO E.O.

SCANIA K-113

411622



COMPONENTES - MÓDULO BASE

BASE DIANTEIRA COM BATENTE

CONJUNTO BASE + BATENTE COFAP
KBC06110

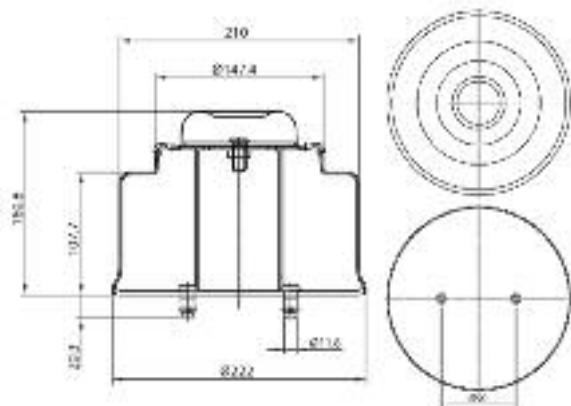

CÓDIGO SIMILAR

GOODYEAR

HT-5351

CÓDIGO E.O.

SCANIA

1440846

BASE TRASEIRA

BASE COFAP
KBC06205

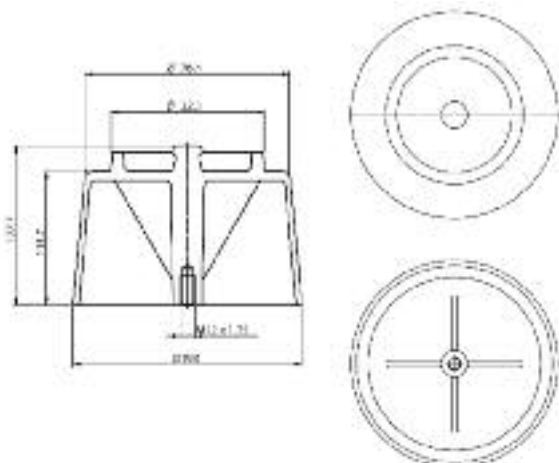

CÓDIGO SIMILAR

GOODYEAR

HT-5010

CÓDIGO E.O.

SCANIA

524100

BASE TRASEIRA

BASE COFAP
KBC06206

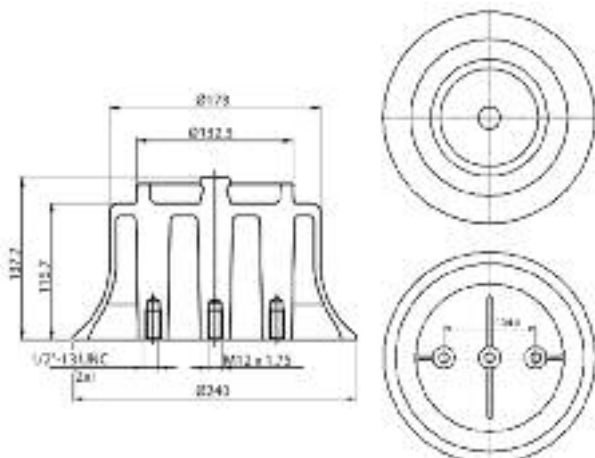

CÓDIGO SIMILAR

GOODYEAR

HT-5020

CÓDIGO E.O.

SCANIA

1673414

SCANIA

539183



Linha de produtos Cofap
 MOLA PNEUMÁTICA
 Componentes - Base



mola pneumática - base

COMPONENTES - MÓDULO BASE

BASE TRASEIRA COM BATENTE

CONJUNTO BASE + BATENTE COFAP KBC06207	CÓDIGO SIMILAR	
	GOODYEAR	HT-5030
	CÓDIGO E.O.	
	SCANIA	1673414
	SCANIA	539183

BASE TRASEIRA

BASE COFAP KBC06208	CÓDIGO SIMILAR	
	GOODYEAR	HT-5066
	CÓDIGO E.O.	
	SCANIA K-113	434931

BASE TRASEIRA COM BATENTE

CONJUNTO BASE + BATENTE COFAP KBC06210	CÓDIGO SIMILAR	
	GOODYEAR	HT-5352
	CÓDIGO E.O.	
	SCANIA	1440847

* imagens meramente ilustrativas

GI



COMPONENTES - MÓDULO BASE

BASE TERCEIRO EIXO COM BATENTE

CONJUNTO BASE + BATENTE COFAP
KBC06211

CÓDIGO SIMILAR

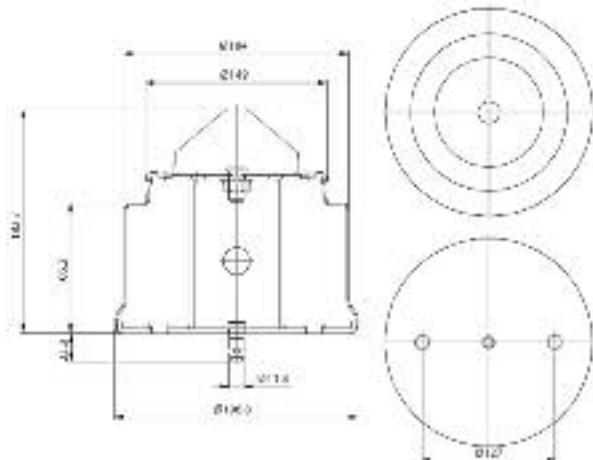

GOODYEAR

HT-5355

CÓDIGO E.O.

SCANIA

1440850

BASE TRASEIRA COM BATENTE

CONJUNTO BASE + BATENTE COFAP
KBC06212

CÓDIGO SIMILAR

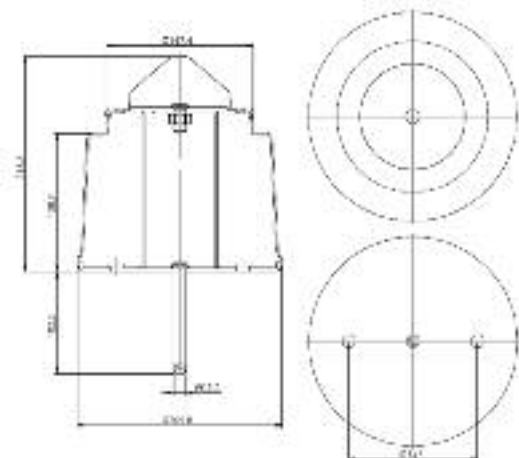

GOODYEAR

HT-5353

CÓDIGO E.O.

SCANIA

1440848

BASE TRASEIRA COM BATENTE

CONJUNTO BASE + BATENTE COFAP
KBC06213

CÓDIGO SIMILAR

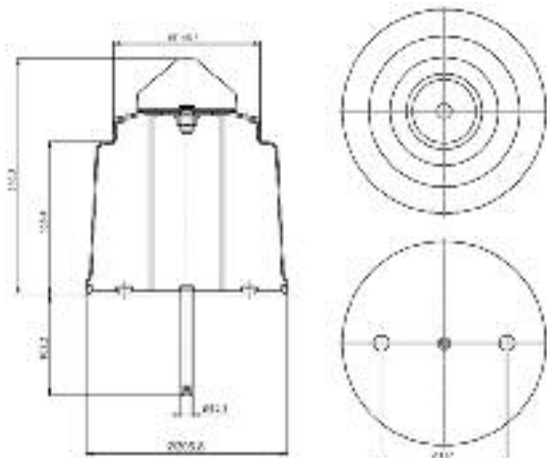

GOODYEAR

HT-5354

CÓDIGO E.O.

SCANIA

1440849



MOLAS PNEUMÁTICAS



CÓDIGO ORIGINAL	CÓDIGO COFAP	CÓDIGO ORIGINAL	CÓDIGO COFAP
CROSS REFERENCE - EQUIPAMENTO ORIGINAL			
355.461	BPC19102	61.386.917	MPC99201
411.622	KBC06109	2036090C1	MPC99203
411.623	BPC06102	2TB 411 099	BPC01102
434.931	KBC06208	2TB 511 101A	BPC01201
434.932	BPC06202	2TB 511 383	BPC01201
470.922	MPC06201	2Z0 616 041A	BPC01101
488.263	MPC06102	305 324 01 08	KBC02102
488.265	MPC06101	A 364.327.7001	BPC02205
488.266	MPC06103	A 364.327.7101	BPC02205
520.242	KBC06111	A 364.327.7301	BPC02205
520.243	BPC06101	A 364 321 00 06	KBC02101
520.244	KBC06104	A 364 321 00 06	KBC02103
523.208	BPC06101	A 382.327.0001	BPC02202
523.229	BPC06201	A 382.327.0101	BPC02203
524.100	KBC06205	A 382.327.7001	BPC02201
533.802	BPC06201	A 382.327.7001	BPC02202
539.183	KBC06206	A 382.327.7101	BPC02202
539.183	KBC06207	A 382.327.7201	BPC02101
539.995	KBC06209	A 382.327.7301	BPC02101
1.134.445	BPC02205	A 382.327.7501	BPC02203
1.137.882	BPC19101	A 634 320 37 34	KBC02201
1.137.888	BPC19101	A 634 320 38 34	KBC02202
1.151.499	MPC06103	A 634.327.0001	BPC02204
1.199.733	BPC19102	A 695.327.0001	BPC02206
1.199.873	BPC02205	Facchini 308 501 705	MPC99208
1.440.301	MPC06101	Facchini 308 501 713	MPC99216
1.440.302	MPC06103	Guerra 5.036.002.015.006	MPC99211
1.440.303	MPC06102	HBZ 80006-03	MPC99208
1.440.304	MPC06201	HBZ 80006-07	MPC99207
1.440.305	MPC06203	Jost AD00100	BPC01202
1.440.306	MPC06201	Jost AD00115	BPC02206
1.440.306	MPC06204	Jost AD00135	BPC99204
1.440.307	MPC06202	Jost AD0076J00	MPC99210
1.440.846	KBC06110	Noma 9 200 164	MPC99205
1.440.847	KBC06210	Noma 9 200 165	MPC99219
1.440.848	KBC06212	Randon 212 100 261	MPC99205
1.440.849	KBC06213	Randon 212 100 278	MPC99211
1.440.850	KBC06211	Randon 212 100 301	MPC99208
1.475.106	MPC06102	Randon 212 007 152	BPC99206
1.515.499	MPC06101	Randon 212 007 153	BPC99205
1.515.501	MPC06201	Randon 218 004 237	MPC99219
1.515.501	MPC06203	Randon 260 000 234	BPC01202
1.515.501	MPC06204	Randon 260 000 552	BPC99204
1.515.502	MPC06202	Recrusul 10079887	BPC99205
1.593.842	BPC19101	Recrusul 10079904	BPC99206
1.622.111	BPC02205	Recrusul 10079904	BPC99206
1.673.407	BPC06101	Silpa 2 210 200 160	MPC99207
1.673.408	KBC06111	Silpa 2 210 200 003	BPC99206
1.673.409	KBC06108	Silpa 2 210 200 003	BPC99206
1.673.412	BPC06201	Silpa 2 210 200 015	BPC99205
1.673.413	KBC06209	Suspensys 212 100 261	MPC99205
1.673.414	KBC06206	Uniferro 02011700	BPC99206
1.673.414	KBC06207	Uniferro 02011700	BPC99206
3.027.271	BPC19104	Uniferro 02012100	BPC01202
3.027.272	BPC19103	Uniferro 02012400	BPC99205
3.159.252	BPC02205	Uniferro 29060002	BPC99204
3.159.253	BPC19101	Volvo 212 100 278	MPC99211
8.127.151	BPC19102		



CÓDIGO GOODYEAR	CÓDIGO COFAP	CÓDIGO FIRESTONE	CÓDIGO COFAP
CROSS REFERENCE - GOODYEAR		CROSS REFERENCE - FIRESTONE	
3010	KBC02101	095.0009	20
3011	KBC02102		BPC19102
5001	KBC06104	095.0021	1R1C-390-310
5008	KBC06108	095.0031	1R1D-445-355
5009	KBC06111	095.0118	1R1A-390-295
5010	KBC06205	095.0121	1R1B-390-270
5020	KBC06206	095.0134	1R1E-335-320
5028	KBC06209	095.0135	1R1E-335-320
5030	KBC06207	095.0171	1R1B 390-270
5055	KBC02201	095.0191	1R2D-460-360
5066	KBC06208	095.0191	1R2D-460-360
5067	KBC06109	095.0197	1R1A-415-285
5351	KBC06110	095.0228	1R1K-380-320
5352	KBC06210	095.0229	1R1K-440-320
5353	KBC06212	095.0244	1R1J-415-285
5354	KBC06213	095.0250	29
5355	KBC06211	095.0255	20 T.3
8013	BPC02101	095.0313	20 T.3
8016	BPC06201	095.0314	1T15M-9
8017	BPC02205	095.0320	1T191-E2 / 1T19F-11
8018	BPC19101	095.0327	20-2 T.3
8019	BPC06101	095.0338	333 T.2
8028	BPC06102	095.0353	20 T.3
8030	BPC02202	095.0356	1T15MT-8
8031	BPC02201	095.0358	203
8034	BPC01202	095.0375	1R1E-440-320
8037	BPC06202	095.0378	1T19F-11
8042	BPC01102	095.0381	1R5P-345-290
8064	BPC99203	095.0382	1R5P-410-290
8072	BPC01101	095.0404	1T15L-4
8077	BPC02206	095.0416	1T15LR-4
8083	BPC99204	095.0416	1T15LR-4
8099	BPC02204	095.0422	1T15L-4
8203	BPC99205	095.0427	1R1K-330-320
8313	BPC01201	095.0431	1T15L-4
8317	BPC02203	095.0446	1T15MQX-3
8325	BPC19102	095.0446	1T15MQX-3
8350	BPC99206	095.0481	1T15LR-4
8404	MPC99101	095.0481	1T15LR-4
8406	MPC99207	095.0481	1T15LR-4
8426	MPC06207	095.0482	1T15MQX-3
8460	KPC06104	095.0482	1T15MQX-3
8461	KPC06203	095.0553	1R1A-415-315
8462	KPC06206	095.0405/095.0484	1T15L-4
8463	KPC06205	290	290
8464	KPC06105		20-2 T.3
8465	KPC06103		
8520	MPC99211		
8521	MPC99210		
8550	MPC99205		
8560	MPC06201		
8561	MPC06203		
8562	MPC06101		
8563	MPC06202		
8564	MPC06102		
8565	MPC06103		
8566	MPC06204		
8631	MPC99201		
8649	MPC99219		
8657	MPC99216		
8666	MPC99208		
8675	KPC99202		
8691	MPC99206		
8711	MPC99204		
8727	MPC99203		
8774	MPC99202		
8911	BPC19104		
8922	BPC19103		

linha de
produtos



**camisa e kit
para motor**



Linha de produtos Cofap Camisa e kit para motor



MARCA / MOTOR CILINDRO / ANO	MODELO	Ø		CAMISAS Medidas Cilindros por Embalagem	KIT COFAP Medidas Cilindros por Embalagem
AGRALE					
M-73 1 cil. (80 /...)	Microtator T-440 Estacionário E-573, 675	73,00		SL.1229..F STD 4	
M-790 (74/...)	Caminhão TX-1600 Carregadeira de Rodas 4200 Painco Trator de Rodas T-440, 4200, 24 HSE/SEI, 4200 28 HSE, 4200 SEI - RD, 4300 HSE/SEI - RS/ SEI - RD	90,00		SL.1174..F STD 1	
M-901 D M-93					
MWM Motor Sprint 4.07 TCA 4 cil	Micro ônibus Vollare A6 Furgovan 8000 MA Marruá	93,00	2,50T 2,00 3,00	SL11592 STD 4	K.21592 1
MWM Motor Sprint 6.07T 6 cil	Caminhão 6000 / 6000 RS Micro ônibus Vollare A6	93,00	2,50T 2,00 3,00	SL11592 STD 4	K.11592 1
MWM TD-229/4 4 cil.	Caminhão 7500 TD	102,00	3,00T 2,50 4,00	SL11346..F STD 1	K.12346 1 (Pino 35mm)
MWM D-229/3 D-229/4 3 / 4 cil.	Caminhão TX-1600 (83/...) Caminhão 1800 D	102,00	3,00T 2,50 4,00	SL11291..F STD 1	K.62291 1 MK62291 1
MWM 4.10 T 4.10 TCA 4 cil.	Caminhão 7500/ 7500 VUC/ 7.5T/ 6000/ 6000 VUC / 8500E-mec e E-mec CD /8.5T / MA 7.9 / MA 8.5 / MA 9.2 13000 E-mec 4X2 e 6X2 Micro Ônibus - Vollare Modelo A8 / W8 Furgovan 8000 E-mec / 6000 E-mec	103,00	3,00T 2,50 4,00	SL11404..F STD 1	K.11404 1 MK11404 1
4.10NA / 6.10NA 4 / 6 cil	Caminhão 4500 D RS, 5000 RD, 5000 RS, 7000 7000 D	103,00	3,00T 2,50 4,00	SL11404..F 1	K.31404 1 MK31404 1
Motor 4.12 TCE Acteon Euro III	Caminhão 8500 E-tronic/ 9200 E-tronic MA7.5E-tronic/ MA8.5E-tronic/ MA9.2E-tronic Volare W8/ W9	105,00	3,00 2,50 3,50		K.07001 1
ATLAS COPCO					
Perkins D-4.203 4 cil.	Compressor - XA / XAS 60 PD Empilhadeira (77/...)	3.602" (91,49)		SL.1136 STD / .020" / .030" 6	
Perkins 4.236 4cil.	Compressor XAS 80 PD (81/82)	3.877" (98,47)		SL11289 STD / .020" .030"/.040" 4 c/ flange	
Perkins 6.354 6 cil.	Compressor XA-160 PD, XAH-120 (80/...)	3.877" (98,47)		SL11289 STD / .020" .030"/.040" 4 c/ flange	
Perkins 4.248 4 cil.	Compressor XA / XAS 120 PD Empilhadeira (71/...)	3.9785" (101,05)		SL.1177 STD / .020" .030"/.040" 4	
Perkins 6.357 6 cil.	Compressor XA-120 PD (84/...)	4.100" (104,14)		SL.1160 STD / .020" .030" 6	
Perkins 6.358 6 cil.	Empilhadeira (71/...)	4.100" (104,14)	3/32" 3/32" 3/16" 3/16"	SL11283 STD / .020" .030"/.040" 6	K.11283 1
Scania DS-11 6 cil.	Compressor XA/XAH-350 SD / PD XA-300 HSD, XAH-315 SD (79/...)	5" (127,00)	3/32" 3/32" 3/16" 3/32" 3/32" 3/16"	SL.1235..F STD 1	K..3335 1 K..5535 1 (1ª canaleta trapezoidal)



MARCA / MOTOR CILINDRO / ANO	MODELO	Ø		CAMISAS Medidas Cilindros por Embalagem	KIT COFAP Medidas Cilindros por Embalagem
BANTAM EMAQ					
MBB OM-352 6 cil.	Guindaste Hidráulico - S 628 (81/84)	97,00	3,00	SL.1153 STD / .020" / .030" / .040" / .050" / .060" / .080" / 0.1" 6	K.11153 1 (Aspirado)
			3,00		
			3,00T		
			3,00	SL.1153 STD / .020" / .030" / .040" / .050" / .060" / .080" / 0.1" 6	K.67153 1 (Anel de Aço)
			3,00		
			3,00T		
			3,00	SL.1153 STD / .020" / .030" / .040" / .050" / .060" / .080" / 0.1" 6	K.22153 1 (Turbinado)
			3,00		
			3,00T		
OM-352 A (3 Canaletas) 6 cil.			2,50	SL.1153 STD / .020" / .030" / .040" / .050" / .060" / .080" / 0.1" 6	K.33153 1
			2,50		
			4,00		
BARBER-GREENE					
Perkins 3.152 3 cil.	Vibro Acabadora 873 (84/...)	3.602" (91,49)		SL.1136 STD / .020" / .030" 6	
MBB 314 4 cil.	Vibro Acabadora SA-41	97,00	3,00	SL.1153 STD / .020" / .030" / .040" / .050" / .060" / .080" / 0.1" 6	K.11153 1 (Aspirado)
			3,00		
			3,00T		
			3,00	SL.1153 STD / .020" / .030" / .040" / .050" / .060" / .080" / 0.1" 6	K.67153 1 (Anel de Aço)
			3,00		
			3,00T		
			3,00	SL11366 STD / .020" s/ flange 6	
			3,00		
			3,00T		
			3,00	SL11485 STD/.020" Pré-Mandrilada 6	
			3,00		
			3,00T		
Perkins 4-236 4cil.	Vibro Acabadora SA-37 S (84/...)	3.877" (98,47)		SL11289 STD / .020" .030" / .040" 4 c/ flange	



Linha de produtos Cofap Camisa e kit para motor



MARCA / MOTOR CILINDRO / ANO	MODELO	Ø		CAMISAS Medidas Cilindros por Embalagem	KIT COFAP Medidas Cilindros por Embalagem
---------------------------------	--------	---	--	---	---

BRASMECÂNICA (TORO)

MWM D-225	Caminhão Fora de Estrada OKD-4500, OK-4400 (84/...)	100,00	3,00T	SL.1145..F STD 1	K..1145 1
			2,00 2,00 4,00		
Caterpillar 3306 T 6 cil.	Carregadeira de Rodas - 350 D (85/...)	4 3/4" (120,65)	3,00T	SL11296..F STD 1	K..1245 1
			2,00 2,00 4,00		
Caterpillar 3306 T 6 cil.	Carregadeira de Rodas - 350 D (85/...)	4 3/4" (120,65)	1/8"	SL11296..F STD 1	K.12296 1
			3/32" 7/32"		

C. CIFALI

Perkins 3-152, 4-203 3 /4cil	Trator SA-11 / 14 / 15 / 16 (84/85)	3.602" (91,49)		SL.1136 STD / .020" / .030" 6	
Perkins 6-358 6 cil.	Trator SA 12 / 13 (84/85)	4.100" (104,14)	3/32" 3/32" 3/16" 3/16"	SL11283 STD / .020" / .030" / .040" 6	K.11283 1

CBT

Perkins D-4.203 4 cil.	Trator - 1000, 1065, 2070 (73/...)	3.602" (91,49)		SL.1136 STD / .020" / .030" 6	
MBB OM-321 6 cil.	Trator de Rodas - 1020, 1090 (62 / 70)	95,00		SL..111 STD / .020" 6	
MBB OM-314 OM-352 4 cil.	Trator - 1065, 2080, 2600 (77/...) Trator - 1000, 1105, 2105, 2600, 8060, 8060/4 (70/...)	97,00	3,00 3,00 3,00 5,50 5,50	SL.1153 STD / .020" / .030" / .040" / .050" / .060" / .080" / 0.1" 6	K.11153 1 (Aspirado)
			3,00T 3,00 3,00 5,50 5,50		
Perkins 6-354.4 6 cil.	Trator - 8260	3.877" (98,47)		SL11289 STD / .020" .030" / .040" 4 c/ flange	
Perkins 4-236 4cil.	Trator - 8240 (84/...)	3.877" (98,47)		SL11289 STD / .020" .030" / .040" 4 c/ flange	
MWM D-229/4 4 cil.	Trator - 8440	102,00	3,00T	SL11291..F STD 1	K.62291 1
			2,50 4,00		
Perkins 4-248 4 cil.	Trator - 8240	3.9785" (101,05)		SL.1177 STD / .020" .030" / .040" 4	
MWM TD-229EC 4 cil.	Trator - 8450	102,00	3,00T 2,50 4,00	SL11346..F STD 1	K.12346 1 (Pino 35mm)



MARCA / MOTOR CILINDRO / ANO	MODELO	Ø		CAMISAS Medidas Cilindros por Embalagem	KIT COFAP Medidas Cilindros por Embalagem
CBT (cont.)					
Perkins 6-357 6 cil.	Trator - 1090 A, 2100 (77/82)	4.100" (104,14)		SL.1160 STD / .020" / .030" 6	
Perkins 6-358 6 cil.	Trator - 2500	4.100" (104,14)	3/32" 3/32" 3/16" 3/16"	SL11283 STD / .020"/ .030" / .040" 6	K.11283 1
CASE					
Perkins 4-203 4 cil.	Trator c/ Carregadeira e Retro-Escavadeira 580 E-CK, 50 E-CK	3.602" (91,49)		SL.1136 STD / .020" / .030" 6	
MBB OM - 314 4 cil.	Carregadeira de Rodas - W20	97,00	3,00 3,00 3,00 5,50 5,50 3,00T 3,00 3,00 5,50 5,50	SL.1153 STD / .020" / .030" / .040" / .050" / .060" / .080" / 0.1" 6 SL.1153 STD / .020" / .030" / .040" / .050" / .060" / .080" / 0.1" 6 SL11366 STD / .020" s/ flange 6	K.11153 1 (Aspirado) K.67153 1 (Anel de Aço)
MBB OM-352 6 cil.	Pá Carregadeira - W20, W18 Carregadeira de Rodas - W20	97,00	3,00 3,00 3,00 5,50 5,50 3,00T 3,00 3,00 5,50 5,50 3,00T 3,00 3,00 5,50 5,50	SL.1153 STD / .020" / .030" / .040" / .050" / .060" / .080" / 0.1" 6 SL.1153 STD / .020" / .030" / .040" / .050" / .060" / .080" / 0.1" 6 SL11366 STD / .020" s/ flange 6 SL11485 STD/.020" Pré-Mandrilada 6	K.11153 1 (Aspirado) K.67153 1 (Anel de Aço) K.22153 1 (Turbinado)
Perkins 4-236 4 cil.	Trator c/ Carregadeira e Retro- Escavadeira - 580 H	3.877" (98,47)		SL11289 STD / .020" .030" / .040" 4 c/ flange	
Perkins 6-357 6 cil.	Trator de rodas - W7E4 (71 / 81)	4.100" (104,14)		SL.1160 STD / .020" / .030" 6	
Perkins 6-358 6 cil.	Estacionário - BH 33	4.100" (104,14)	3/32" 3/32" 3/16" 3/16"	SL11283 STD / .020"/ .030" / .040" 6	K.11283 1

70

camisa e kit para motor



Linha de produtos Cofap Camisa e kit para motor



MARCA / MOTOR CILINDRO / ANO	MODELO	Ø		CAMISAS Medidas Cilindros por Embalagem	KIT COFAP Medidas Cilindros por Embalagem
GATERPILLAR					
D-330 D-330 A/B Veicular 1670 333 A/B D-348 4/6 cil.	Estacionário - D4, D6 Carregadeira de Rodas - 955, 922B, 966 B/C, 944, 946, 977 Motoniveladora - 112 E/F, 12 E/F, 14 E, 120, 112 E Trator de Rodas - D5, D6 - B/C/D, D-7 F Trax - Cavator - 950, 951 B, 955 - H/F/K, 966 A, 977 - HK	4 1/2" (114,30)	1/8" 3/32" 7/32"	SL.1113..F STD 1	K..1113 1
D-3304 / D-3304T D-3306, D-3306T D-330, D-333, D-334 4 / 6 cil.	Carregadeira de Rodas - 910, 930/R, 931, 941-B, 950, 951-C, 955-L, 966 C/R Estacionário - D4 Escavadeira Hidráulica - 225 Motoniveladora - 12E/G, 120B / G / E, 140 B Moto Scrapers - 621 / R, 631 D, 627 B Pipelayer - 561, 571 G Skidder - 518, 528 Trator - D3, D3LGP, D4D - LGP, D5SA, D5LGP, D6CLGP, D7 Trator de Esteira - D6C, DD/PS D6D - DD/PS, D - 40 - DD / PS, D4 -DD / PS / SA Wheeltractor - 814, 815, 816	4 3/4" (120,65)	1/8" 3/32" 7/32" 1/8" 3/32" 7/32" 3,16 2,38 3,16 3,16T 3,16T 3,16 3,16T 5,54T 3,34	SL11296..F STD 1	K.12296 1 K.22296 1 K.44296 1 K.33296 1 K.55296 1
Motor 3114 / 3116 6 cil.			3,00T 3,00T 4,00		K.11001 1 K.11002 1 K.11003 1
Motor 3408			3,95T 3,16T 3,16		K.11004 1
Motor Série 300 4/6/8/12 cil.	D339 / D342 / D364 / D375 / D386 / D397 D-13000 Estacionário - D-7, D-8 Trator - D-7/C/D/E, D-8/E/F, D-G/H Pipelayer - 572 C/D/E, 583 C/E/H	5 3/4" (146,05)	4,75 2,39 6,34 4,76T 2,38T 6,34	SL.1207..F STD 1	K.12254 1 K.22254 1
CLARK					
Agrale M-790 2 cil.	Carregadeira de Rodas BOBCAT 711 Trator c/ Carregadeira e Retro-Escavadeira NJS-908B (80/...)	90,00		SL.1174..F STD 1	
Perkins 3-152, 4-203 3 / 4 cil.	Empilhadeira - BOBCAT, C-300FY, C-40, C-60, 300 HY - 40 / 50 / 60 Empilhadeira - C 500HY, C-300Y50 / 60 / 70D C-500Y110 / 155 (66/...)	3.602" (91,49)		SL.1136 STD / .020" / .030" 6	
MBB OM-314 4 cil.	Michigan Guindastes Hidráulica 714, 720 Pá Carregadeira - 55, ART/ 55 G / 55 H / 75 H (76/...)	97,00	3,00 3,00 3,00 5,50 5,50 3,00T 3,00 3,00 5,50 5,50	SL.1153 STD / .020" / .030" / .040" / .050" / .060" / .080" / 0.1" 6 SL.1153 STD / .020" / .030" / .040" / .050" / .060" / .080" / 0.1" 6 SL11366 STD / .020" s/ flange 6 SL11485 STD/.020" Pré-Mandrilada 6	K.11153 1 (Aspirado) K.67153 1 (Anel de Aço)



MARCA / MOTOR CILINDRO / ANO	MODELO	Ø		CAMISAS Medidas Cilindros por Embalagem	KIT COFAP Medidas Cilindros por Embalagem
CLARK (cont.)					
MBB OM-352 6 cil.	Carregadeira de Rodas -55 75 III / HD, 45C	97,00	3,00	SL.1153 STD / .020" / .030" / .040" / .050" / .060" / .080" / 0.1" 6	K.11153 1 (Aspirado)
			3,00		
			3,00T		
			3,00	SL.1153 STD / .020" / .030" / .040" / .050" / .060" / .080" / 0.1" 6	K.67153 1 (Anel de Aço)
			3,00		
			3,00T		
			3,00	SL.1153 STD / .020" / .030" / .040" / .050" / .060" / .080" / 0.1" 6	K.22153 1 (Turbinado)
			3,00		
			3,00T		
			5,50	SL11366 STD / .020" s/ flange 6	
			5,50		
			5,50		
			5,50	SL11485 STD/.020" Pré-Mandrilada 6	
			5,50		
			5,50		
MBB OM-352 A 3 Canaletas 6 cil.	Guindaste Hidráulico - 720 - OS (80/84)	97,00	2,50	SL.1153 STD / .020" / .030" / .040" / .050" / .060" / .080" / 0.1" 6	K.33153 1
			2,50		
			4,00		
				SL11366 STD / .020" s/ flange 6	K.43153 1 (c/ rebaixo de válvulas)
COLES / BARDELA					
Scania D-11 6 cil.	18 / 22 T (76/77)	5" (127,00)	3/32" 3/32" 3/16"	SL.1235..F STD 1	K..2335 1
CUMMINS					
Motor Série C	Turbo	114,00	3,50T 3,00T 4,00		K.15002 1
	6CT AA 8,3L 91/...		K.15001 1		
	6CT 8,3L		K.15013 1		
	6CTA 8,3L 91/...		K.15003 1		
	6C 8,3L 91/...		K.15004 1		
	6C 8,3L		K.15005 1		
	6CT 8,3L		K.15006 1		
	6CTA 8,3L		K.15015 1		
Motor Série C	.../91	114,00	3,50T 3,00T 3,00		K.15007 1
	6CTAA 8,3L .../91		K.15008 1		
	6CTA 8,3L .../91		K.15009 1		
	6C 8,3L .../91		K.15010 1		



Linha de produtos Cofap Camisa e kit para motor



MARCA / MOTOR CILINDRO / ANO	MODELO	Ø		CAMISAS Medidas Cilindros por Embalagem	KIT COFAP Medidas Cilindros por Embalagem		
CUMMINS (cont.)							
Motor Série C	00/...	114,00	3,50T 3,00T 3,00		K.15014 1		
	8,3L 00/...				K.15011 1		
	8,3L 00/...				K.15012 1		
	CTA 8,3L				K.15016 1		
	CT 8,3L				K.15017 1		
DODGE (CHRYSLER)							
Perkins 4-236 4 cil.	DD-400 / P-400 (.../81)	3.877" (98,47)		SL11289 STD / .020" .030" / .040" 4 c/ flange			
MWM D-229 6 cil.	D-950 D, D-14000 TD (.../81)	102,00	3,00T 2,50 4,00	SL11291..F STD 1	K.62291 1		
					MK62291 1		
TD-229 / TD-229 EC 6 cil.			3,00T 2,50 4,00	SL11346..F STD 1	K.12346 1 (Pino 35mm)		
Perkins 6-357 6 cil.	P-700, D-780 DI, P-900 (70 / 81)	4.100" (104,14)		SL.1160 STD / .020" .030" 6			
DRESSER (HUBER WABCO)							
MBB OM-352 A 3 canaletas 6 cil.	Motonivelador - 130 M (77/82)	97,00	2,50 2,50 4,00	SL.1153 STD / .020" / .030" / .040" / .050" / .060" / .080" / 0.1" 6	K.33153 1		
					K.43153 1 (c/ rebaixo de válvulas)		
MBB OM-352 6 cil.	Guindaste Hidráulico - 150A, 660 (74/...)	97,00	3,00 3,00 3,00 5,50 5,50	SL.1153 STD / .020" / .030" / .040" / .050" / .060" / .080" / 0.1" 6	K.11153 1 (Aspirado)		
					3,00T 3,00 3,00 5,50 5,50	SL.1153 STD / .020" / .030" / .040" / .050" / .060" / .080" / 0.1" 6	K.67153 1 (Anel de Aço)
							3,00T 3,00 3,00 5,50 5,50
			SL11366 STD / .020" s/ flange 6				
				SL11485 STD/.020" Pré-Mandrilada 6			
					MBB OM-314 4 cil.	Guindaste de Cabos - Galion 9TM, Krenark AX / AY Trator com Carregadeira e Retro- Escavadeira, Trator de Rodas- 660 M II	97,00



MARCA / MOTOR CILINDRO / ANO	MODELO	Ø		CAMISAS Medidas Cilindros por Embalagem	KIT COFAP Medidas Cilindros por Embalagem
DRESSER (HUBER WABCO) (cont.)					
				SL.1153 STD / .020" / .030" / .040" / .050" / .060" / .080" / 0.1" 6 SL11366 STD / .020" s/ flange 6 SL11485 STD/.020" Pré-Mandrilada 6	K.67153 1 (Anel de Aço)
Scania D-11 / DS-11 6 cil.	Escavadeira Hidráulica - 140S, 165 S, 165 SSA, 225 SSA	5" (127,00)		SL.1130..F STD 1 SL.1235..F STD 1	K..2335 1
DYNAPAC					
MBB OM-314 4 cil.	Rolo Compactador de Pneus Autopropelido CP-22 Rolo Compactador Vibratório Autopropelido CA-35D	97,00	3,00T 3,00 3,00 5,50 5,50 3,00T 3,00 3,00 5,50 5,50	SL.1153 STD / .020" / .030" / .040" / .050" / .060" / .080" / 0.1" 6 SL.1153 STD / .020" / .030" / .040" / .050" / .060" / .080" / 0.1" 6 SL11366 STD / .020" s/ flange 6 SL11485 STD/.020" Pré-Mandrilada 6	K.11153 1 (Aspirado) K.67153 1 (Anel de Aço)
MBB OM-352 6 cil.	Rolo Compactador Vibratório Autopropelido CA-25A / D / PD / S , CC-43 (76/...)	97,00	3,00T 3,00 3,00 5,50 5,50 3,00T 3,00 3,00 5,50 5,50	SL.1153 STD / .020" / .030" / .040" / .050" / .060" / .080" / 0.1" 6 SL.1153 STD / .020" / .030" / .040" / .050" / .060" / .080" / 0.1" 6 SL11366 STD / .020" s/ flange 6 SL11485 STD/.020" Pré-Mandrilada 6	K.11153 1 (Aspirado) K.67153 1 (Anel de Aço) K.22153 1 (Turbinado)
Perkins 4-236 4 cil.	Rolo Compactador Vibratório Autopropelido CC-21 / CA-15 / CP-15 / CP-22	3.877" (98,47)		SL11289 STD / 0,20" 0,30" / 0,40" 4 c/ flange	



Linha de produtos Cofap Camisa e kit para motor



MARCA / MOTOR CILINDRO / ANO	MODELO	Ø		CAMISAS Medidas Cilindros por Embalagem	KIT COFAP Medidas Cilindros por Embalagem
DYNAPAC (cont.)					
Perkins 6-354 4 cil.	Rolo Compactador Vibratório Autopropelido CP-27	3.877" (98,47)		SL11289 STD / 0,20" 0,30" / 0,40" 4 c/ flange	
MWM D-225 3 cil.	Rolo Compactador Vibratório CH-44 / 46, CF-44	100,00	3,00T 2,00 2,00 4,00	SL.1145..F STD 1	K..1145 1
D-225 4 cil.	Rolo Compactador Vibratório CHB-66, CFB-66 (76/...)		3,00T 2,00 2,00 4,00	SL.1145..F STD 1	K..1245 1
MWM D-229	Rolo Compactador Vibratório CFH-44, CFH-66 , CA-15	102,00	3,00T 2,50 4,00	SL11291..F STD 1	K.62291 1 MK62291 1
MWM D-226 4 cil. (76/...)	Rolo Compactador Vibratório Autopropelido CA-15 / D / PD	105,00		SL.1159 STD / 0,10" 0,20" / 0,30" 0,40" 1	
Scania D-11 6 cil.	Rolo Compactador Estacionário Autopropelido CT / TR-25 Trator de Rodas TR-25	5" (127,00)	3/32" 3/32" 3/16"	SL.1235..F STD 1	K..2335 1
EATON / YALE					
Perkins 4-203 4 cil.	Empilhadeira Yale Tome D-83P, D-87P, G51P (70/...)	3.602" (91,49)		SL.1136 STD / .020" / .030" 6	
MBB OM-352 6 cil.	Carregadeira de Rodas 134BR, 1500 B, 1900 B, 3000 B (76/...)	97,00	3,00	SL.1153 STD / .020" / .030" / .040" / .050" / .060" / .080" / 0.1" 6	K.11153 1 (Aspirado)
			3,00		
			3,00T		
			3,00		
3,00	SL.1153 STD / .020" / .030" / .040" / .050" / .060" / .080" / 0.1" 6	K.67153 1 (Anel de Aço)			
3,00					
3,00					
3,00					
3,00	SL.1153 STD / .020" / .030" / .040" / .050" / .060" / .080" / 0.1" 6	K.22153 1 (Turbinado)			
3,00					
3,00					
3,00					
3,00	SL.11366 STD / .020" s/ flange 6				
3,00					
3,00					
3,00					
3,00	SL.11485 STD/.020" Pré-Mandrilada 6				
3,00					
3,00					
3,00					
Perkins 6-357	Pá Carregadeira 250, 134A, 1500	4.100" (104,14)		SL.1160 STD / .020" / .030" 6	
Scania D-11 6 cil	Carregadeira de Rodas 3000B	5" (127,00)	3/32"	SL.1235..F STD 1	K..2335 1
			3/32" 3/16"		
				SL.1130..F STD 1	



MARCA / MOTOR CILINDRO / ANO	MODELO	Ø		CAMISAS Medidas Cilindros por Embalagem	KIT COFAP Medidas Cilindros por Embalagem
ENGESA					
MBB OM-352 A 3 canaletas 6 cil	Caminhão Fora de Estrada EE-25 4 X 4, 6 X 6 (80/...)	97,00	2,50 2,50 4,00	SL.1153 STD / .020" / .030" / .040" / .050" / .060" / .080" / 0.1" 6 SL11366 STD / .020" s/ flange 6 SL11485 STD/.020" Pré-Mandrilada 6	K.33153 1 K.43153 1 (c/ rebaixo de válvulas)
MBB OM-352 6 cil.	Caminhão Fora de Estrada EE-15 4 X 4	97,00	3,00 3,00 3,00 5,50 5,50 3,00T 3,00 3,00 5,50 5,50 3,00T 3,00 3,00 5,50 5,50	SL.1153 STD / .020" / .030" / .040" / .050" / .060" / .080" / 0.1" 6 SL.1153 STD / .020" / .030" / .040" / .050" / .060" / .080" / 0.1" 6 SL.1153 STD / .020" / .030" / .040" / .050" / .060" / .080" / 0.1" 6 SL11366 STD / .020" s/ flange 6 SL11485 STD/.020" Pré-Mandrilada 6	K.11153 1 (Aspirado) K.67153 1 (Anel de Aço) K.22153 1 (Turbinado)
MWM D-225 / 6 6 cil.	Trator de Rodas EL-510 (79/...)	100,00	3,00T 2,00 2,00 4,00 3,00T 2,00 2,00 4,00	SL.1145..F STD 1 SL.1145..F STD 1	K..1145 1 K..1245 1
MWM D-229 / 6 6 cil.	Trator Florestal EE-510	102,00	3,00T 2,50 4,00	SL11291..F STD 1	K.62291 1 MK62291 1
Perkins 6-357 6 cil.	Caminhão Fora de Estrada EE-15	4.100" (104,14)		SL.1160 STD / .020" .030" 6	
Scania D-11 6 cil.	Caminhão Fora de Estrada EE-50 6 X 6	5" (127,00)	3/32" 3/32" 3/16"	SL.1235..F STD 1	K..2335 1
FENDT					
MWM AKD 112 / 12 2 cil.	Trator F-51 (66/69)	98,00		SL.1133..F STD 1	
FIAT - ALLIS					
MBB OM-352 6 cil	Carregadeira de Rodas FR-10 M / 11 M / 12 M / 134 BR, 1500 B, 1900 B (78/...) Guindaste Hidráulico - 150 A	97,00	3,00 3,00 3,00 5,50 5,50	SL.1153 STD / .020" / .030" / .040" / .050" / .060" / .080" / 0.1" 6	K.11153 1 (Aspirado)



Linha de produtos Cofap
Camisa e kit para motor



MARCA / MOTOR CILINDRO / ANO	MODELO	Ø		CAMISAS Medidas Cilindros por Embalagem	KIT COFAP Medidas Cilindros por Embalagem	
FIAT - ALLIS (cont.)						
				3,00T 3,00 3,00 5,50 5,50	SL.1153 STD / .020" / .030" / .040" / .050" / .060" / .080" / 0.1" 6	K.67153 1 (Anel de Aço)
				3,00T 3,00 3,00 5,50 5,50	SL.1153 STD / .020" / .030" / .040" / .050" / .060" / .080" / 0.1" 6	K.22153 1 (Turbinado)
					SL11366 STD / .020" s/ flange 6	
					SL11485 STD/.020" Pré-Mandrilada 6	
MWM D-225 / 6 6 cil.	Carregadeira de Rodas F-18 Escavadeira Hidráulica S-90 Trator de Esteira AD-7B	100,00		3,00T 2,00 2,00 4,00	SL.1145..F STD 1	K..1145 1
				3,00T 2,00 2,00 4,00	SL.1145..F STD 1	K..1245 1
MWM D-229/6 6 cil.	Carregadeira de Rodas FR-10-B Escavadeira Hidráulica S-90 Trator de Esteira 7BTA, 7DEO, 7D Hidráulica 7D-TA (81/...)	102,00		3,00T 2,50 4,00	SL11291..F STD 1	K.62291 1 MK62291 1
MWM TD-229EC 6 cil.	Trator FD-9	102,00		3,00T 2,50 4,00	SL11346..F STD 1	K.12346 1 (Pino 35mm)
Scania D-11 6 cil.	Trator de Esteira AD-14/C, 14SEOAD, 14SCOAD, 14SCOBD, 14STA (71/...)	5" (127,00)			SL.1130..F STD 1	
				3/32" 3/32" 3/16"	SL.1235..F STD 1	K..2335 1
FNV - BUCYRUS						
Perkins 6-357 6 cil.	Guindaste de Cabos 22 B	4.100" (104,14)			SL.1160 STD / .020" / .030" 6	
Scania D-11 6 cil.	Guindaste de Cabos 30 T (80/...)	5" (127,00)		3/32" 3/32" 3/16"	SL.1235..F STD 1	K..2335 1
FORD TRATORES						
4-203 Injeção Direta 3 / 4 / 6 cil. (61/...)	Trator	3.602" (91,49)		3/32" 3/32" 1/8" 1/4" 1/4"	SL.1136 STD / .020"/ .030" 6	K.11339 1
Motor FNH 256 NA	Trator 5600 / 5610 (Curso Curto)	4.400" (111,76)		2,38 2,38 2,38 4,76	SL.1212 STD / .020" 1	K.11402 1
Motor 4600 / 4610 Motor FNH 201-NA 3.3L Motor FNH 268-NA 4.2L	Trator 6600/6610/TR4 Retroescavadeira 6600					K.21402 1



MARCA / MOTOR CILINDRO / ANO	MODELO	Ø		CAMISAS Medidas Cilindros por Embalagem	KIT COFAP Medidas Cilindros por Embalagem
---------------------------------	--------	---	---	---	---

GARDNER DENVER (COMPRESSOR)

Perkins 6-354 6 cil.	Compressor Portátil SP-340	3.877" (98,47)		SL11289 STD / .020" .030" / .040" 4 c/ flange	
----------------------------	----------------------------	-------------------	--	--	--

GENERAL MOTORS

MWM Motor Sprint 4.07TCA 4 cil		93,00	2,50T 2,00 3,00	SL11592 STD 4	K.21592 1
MWM Motor Sprint 6.07T 6 cil	GMC - 6.150 Pick-Up / Silverado	93,00	2,50T 2,00 3,00	SL11592 STD 4	K.11592 1
Maxion S-4T / S-4T Turbo	Pick-up D-20 e D-40 (92/...) D-20 Cabine Dupla D-20 Turbo Cabine Dupla Caminhão 6000 Turbo Caminhão 6000 / 6-100 / 6-150 Turbo	100,00	3,00T 2,50 4,00	SL11390 STD / .020" 4	K.11390 1
S-4 Asp. 4 cil.				SL11390 STD / .020" 4	K.21390 1
	P4000T			SL11390 STD / .020" 4	K.52390 1
	P4000			SL11390 STD / .020" 4	K.22390 1
	S4 Euro I			SL11390 STD / .020" 4	K.32390 1
	S4T Euro I			SL11390 STD / .020" 4	K.42390 1
	Série 1000 Turbo		3,50 2,50 4,00	SL11390 STD / .020" 4	K.33390 1
Perkins 6-357 6 cil.	Caminhão F-600 D, D-60, D-70 (62/80)	4.100" (104,14)		SL.1160 STD / .020" .030" 6	
Perkins 6-358 6 cil.	Caminhão D-60D, D-70, D-80 (80/...)	4.100" (104,14)	3/32" 3/32" 3/16" 3/16"	SL11283 STD / .020" .030" / .040" 6	K.11283 1
Perkins 6-357 / 63572 6 cil. (66/82)	Caminhão D-60 / B-70	4.100" (104,14)	3/32" 3/32" 1/4" 1/4"	SL.1160 STD / .020" .030" 6	K.11340 1

HOEKUETSU (COMPRESSOR)

Perkins 6-354 6 cil.	Compressor PDR-250	3.877" (98,47)		SL11289 STD / .020" .030" / .040" 4 c/ flange	
----------------------------	--------------------	-------------------	--	--	--

HOLMAN COMPAIR (COMPRESSOR)

Perkins 4-236 4 cil.	Compressor Portátil CR-175/5 (77/...)	3877" (98,47)		SL11289 STD / .020" / .030" / .040" 4 c/ flange	
Perkins 6-357 6 cil.	Compressor Portátil 275/S, CR-275/S	4.100" (104,14)		SL.1160 STD / .020" / .030" 6	
Perkins 6-358 6 cil.	Compressor Portátil CR-370 (84/...)	4.100" (104,14)	3/32" 3/32" 3/16" 3/16"	SL11283 STD / .020" .030" / .040" 6	K.11283 1

HOOS (COMPRESSOR)

Agrale M-790 2 cil.	Compressor Portátil C-21 MD (81/82)	90,00		SL.1174..F STD 1	
---------------------------	--	-------	--	-------------------------------	--



Linha de produtos Cofap Camisa e kit para motor



MARCA / MOTOR CILINDRO / ANO	MODELO	Ø		CAMISAS Medidas Cilindros por Embalagem	KIT COFAP Medidas Cilindros por Embalagem
---------------------------------	--------	---	--	---	---

HOOS (COMPRESSOR) (cont.)

MBB OM-352 A 3 Canaletas 6 cil.	Compressor C-28 MD (81/82)	97,00	2,50 2,50 4,00	SL.1153 STD / .020" / .030" / .040" / .050" / .060" / .080" / 0.1" 6 SL11366 STD / .020" s/ flange 6	K.33153 1 K.43153 1 (c/ rebaixo de válvulas)
MBB OM-314 4 cil.	Compressor F-6 / 1ED	97,00	3,00 3,00 3,00 5,50 5,50 3,00T 3,00 3,00 5,50 5,50	SL.1153 STD / .020" / .030" / .040" / .050" / .060" / .080" / 0.1" 6 SL.1153 STD / .020" / .030" / .040" / .050" / .060" / .080" / 0.1" 6 SL11366 STD / .020" s/ flange 6 SL11485 STD/.020" Pré-Mandrilada 6	K.11153 1 (Aspirado) K.67153 1 (Anel de Aço)
MBB OM-352 6 cil.	Compressor F9MD, C26MD, F9 / 1 ED / ED	97,00	3,00 3,00 3,00 5,50 5,50 3,00T 3,00 3,00 5,50 5,50 3,00T 3,00 3,00 5,50 5,50	SL.1153 STD / .020" / .030" / .040" / .050" / .060" / .080" / 0.1" 6 SL.1153 STD / .020" / .030" / .040" / .050" / .060" / .080" / 0.1" 6 SL11366 STD / .020" s/ flange 6 SL11485 STD/.020" Pré-Mandrilada 6	K.11153 1 (Aspirado) K.67153 1 (Anel de Aço) K.22153 1 (Turbinado)

INGERSOLL RAND (COMPRESSOR)

Perkins 4-203 4 cil.	Compressor Portátil DR-125, DR-160 (76/84)	3.602" (91,49)		SL.1136 STD / .020" / .030" 6	
Perkins 6-357 6 cil.	Compressor Portátil DR-250, DR-275 (80/...)	4.100" (104,14)		SL.1160 STD / .020" / .030" 6	
Scania DS-11 6 cil.	Compressor Portátil EXL-725 H, DXL-750, EXL-750, DXL-850 (81/84)	5" (127,00)	3/32" 3/32" 3/16" 3/32" 3/32" 3/16"	SL.1235..F STD 1	K..3335 1 K..5535 1 (1ª Canaleta trapezoidal)



MARCA / MOTOR CILINDRO / ANO	MODELO	Ø		CAMISAS Medidas Cilindros por Embalagem	KIT COFAP Medidas Cilindros por Embalagem
MERCEDES-BENZ					
OM-321 6 cil. (58/71)	Veicular, Industrial, Agrícola	95,00		SL..111 STD / .020" 6	
OM-314 4 cil. (71/...)	Caminhão - 608 D, LO-608	97,00	3,00 3,00 3,00 5,50 5,50	SL.1153 STD / .020" / .030" / .040" / .050" / .060" / .080" / 0.1" 6	K.11153 1 (Aspirado)
			3,00T 3,00 3,00 5,50 5,50	SL.1153 STD / .020" / .030" / .040" / .050" / .060" / .080" / 0.1" 6	K.67153 1 (Anel de Aço)
			3,00T 3,00 3,00 5,50 5,50	SL.1153 STD / .020" / .030" / .040" / .050" / .060" / .080" / 0.1" 6	K.22153 1 (Turbinado)
OM-314 / OM-352 4 cil 6 cil	Caminhão 608E / 704E/ 1113 / 1124 / 1313 1314/ 1513/ 1514/ 2013/ 2014/ 2213/ 2214		3,00T 3,00 3,00 5,50 5,50	SL.1153 STD / .020" / .030" / .040" / .050" / .060" / .080" / 0.1" 6 SL11366 STD / .020" s/ flange 6 SL11485 STD/.020" Pré-Mandrilada 6	K.66153 1 (Anel de Aço)
OM-322 OM-344 OM-352/A 6 cil. (69/...)	L-2013, LK/L/LB-2213, LO-1113, LO-1513, O-352, O-362, OF/OH-1313, O-364 - 11R/12R, OF-1113, L/LK/LS/LA/LAK-1313, L/LK-1513, L-2013 L/LK/LB-2213, L /LK/LS-1113, L-114, LP-1113, L-2013 (70/...)	97,00	3,00 3,00 3,00 5,50 5,50	SL.1153 STD / .020" / .030" / .040" / .050" / .060" / .080" / 0.1" 6	K.11153 1 (Aspirado)
			3,00T 3,00 3,00 5,50 5,50	SL.1153 STD / .020" / .030" / .040" / .050" / .060" / .080" / 0.1" 6	K.67153 1 (Anel de Aço)
			3,00T 3,00 3,00 5,50 5,50	SL.1153 STD / .020" / .030" / .040" / .050" / .060" / .080" / 0.1" 6	K.22153 1 (Turbinado)
			3,00T 3,00 3,00 5,50 5,50	SL.1153 STD / .020" / .030" / .040" / .050" / .060" / .080" / 0.1" 6 SL11366 STD / .020" s/ flange 6 SL11485 STD/.020" Pré-Mandrilada 6	K.66153 1 (Anel de Aço)
OM-352 A (3 Canaletas) 6 cil.		97,00	2,50 2,50 4,00	SL.1153 STD / .020" / .030" / .040" / .050" / .060" / .080" / 0.1" 6	K.33153 1 K.43153 1 (c/ rebaixo de válvulas)
OM-314 A OM-352 A 6 cil. Turb.	O-364, LS-1313, LA/LAK-1316, OH-1316	97,00	3,00 3,00 3,00 5,50 5,50	SL.1153 STD / .020" / .030" / .040" / .050" / .060" / .080" / 0.1" 6	K.11153 1 (Aspirado)



Linha de produtos Cofap Camisa e kit para motor



MARCA / MOTOR CILINDRO / ANO	MODELO	Ø		CAMISAS Medidas Cilindros por Embalagem	KIT COFAP Medidas Cilindros por Embalagem	
MERCEDES-BENZ (cont.)						
				3,00T 3,00 3,00 5,50 5,50	SL.1153 STD / .020" / .030" / .040" / .050" / .060" / .080" / 0.1" 6 SL11366 STD / .020" s/ flange 6	K.67153 1 (Anel de Aço)
OM-364A, OM-366A, Turbo / Intercooler (Biela Trapezoidal) 4 / 6 cil. (87/...)	712, 912, 914, L0-812, L-1218, L-1418E, LK1418, LAK-1418E, L-1618, LK-1618, O-317 U , OF-1318, L-1621, LK-1621, 1218, 1414K, 1418K,1418,1718, 1718K, 1721, 1721S, L-2318 (6 X 4), L-2318K (6 X 4) ,	97,50		2,50T 2,50 4,00	SL.1153 STD / .020" / .030" / .040" / .050" / .060" / .080" / 0.1" 6	K.64153 1
OM-364A, OM-366A/LA, Turbinado Turbo / Intercooler (Biela Paralela) 4 / 6 cil. (87/...)	L-1218, L-1418E, LK1418, LAK-1418E, L-1618, LK-1618, L-1621, LK-1621, 1218	97,50		2,50T 2,50 4,00	SL.1153 STD / .020" / .030" / .040" / .050" / .060" / .080" / 0.1" 6 SL11366 STD / .020" s/ flange 6	K.44153 1
OM-364, OM-366, Aspirado Turbinado 4 / 6 cil. (87/...)	L-1218, L-1418E, LK1418, LAK-1418E, L-1618, LK-1618, L-1621, LK-1621, 1218	97,50		2,50T 2,50 4,00	SL.1153 STD / .020" / .030" / .040" / .050" / .060" / .080" / 0.1" 6 SL11366 STD / .020" s/ flange 6	K.54153 1 Aspirado
OM-364A / OM-366A / OM-366LA		97,50		2,50T 2,50 4,00	SL.1153 STD / .020" / .030" / .040" / .050" / .060" / .080" / 0.1" 6	K.55153 1 (Biela Trapezoidal)
OM-366 LA		97,50		2,50T 2,50 4,00	SL.1153 STD / .020" / .030" / .040" / .050" / .060" / .080" / 0.1" 6	K.56153 1
OM-904 / 906 LA 4 cil.	LO 915, ACCELO 915C, ACCELO 915E, ATEGO 1315, OF 1418, ATEGO 1418, ATEGO 1518, ATEGO 1718, ATEGO 1725 (4x4), 2726/ Axor 1933/ Axor 2826, 2831 6x4, 2423B 6x4, 2423 K 6x4, 2428 6x4, O 500M, O500 BUGGY 4x2, ATEGO 1725, 1728, 1728S, 1728 6x2/ 915 E/ 915 C/ L 1318/ L 1620 (6x2)	102,00		3,00 2,50 4,00	SL.11924 STD	K.11924 1 (Pino 40,0mm) K.12924 1 (Pino 42,0mm)
O-447 LA/ OM-449 A/ 449 LA (turbocooler) 6 cil.	Caminhão LS-1634, LS-1935, LS-1941 L-2635 (6 X 4), LS-2635 (6 X 4) LS-2638 PL O-400 RSD / RSE	128,00		3,00T 3,00 4,00	SL11419..F STD 1	K.11419 1 (.../95)
OM-447 LA (turboalim.) 5 cil.	Caminhão L-1625, LS-1625, L-2325, LK-2325, LB-2325 (6 X 4)					K.21419 1 (95/...)



MARCA / MOTOR CILINDRO / ANO	MODELO	Ø		CAMISAS Medidas Cilindros por Embalagem	KIT COFAP Medidas Cilindros por Embalagem
MERCEDES-BENZ (cont.)					
OM-355/5 Asp. 5 cil. (73/...)	L / LK / LG / LS-1519, LB / L / LK-2219 , LG - 1819 L / LS-1418, LS - 1924, LS - 1929, OH-1517, O-364, OH-1419, LS-1524 (73/...)	128,00		SL11363 STD / .010" / .020" / .030" / .040" 1	
OM-355 / 5 Turbinado 5 cil.	LA 1934	128,00		SL11363 STD / .010" / .020" / .030" / .040" 1	
OM-355/6 OM-346 Aspirado 6 cil. (74/...)	LS-1924, LS-1929, O-355, O-384 (74/...)	128,00		SL11363 STD / .010" / .020" / .030" / .040" 1	
OM-355/6/A OM-346 Turb. 6 cil. (74/...)	LS-1929, O-370 RS / RSD, LS-1932 (76/...)	128,00		SL11363 STD / .010" / .020" / .030" / .040" 1	
OM-355/6/A Turb. / Intercooler 6 cil. (74/...)	LA 1934	128,00		SL11363 STD / .010" / .020" / .030" / .040" 1	
OM-457 LA Injeção Eletrônica	O 500RS, O 500RSD, O 400RSD, O 400RSE, LS 1634 / AXOR 2035 2040 2044 2540 2544 6X2 3340 3344 4140 4144 6X4 LS 1938, LS 1938 S, LS 1938 S 6x2, L 2638 6x4, LS 2638 6x4, LK 2638 6x4	128,00	3,00 3,00 4,00	SL11852..F STD 1	K.11852 1
MWM					
MOTOR SPRINT 4.07TCA 4 cil	Industrial e Marítimo Agrale / GM / Nissan / Troller / Megatech VW	93,00	2,50T 2,00 3,00	SL11592 STD 4	K.21592 1 K.31592 1
MOTOR SPRINT 6.07T 6 cil	Agrale / GM / Ford Industrial e Marítimo	93,00	2,50T 2,00 3,00	SL11592 STD 4	K.11592 1
AKD - 12 AKD - 112 1 / 2 / 3 / 4 cil. (57/68)		98,00		SL.1133..F STD 1	
D-222 BF 2 / 3 / 4 / 6 cil. 1014 E 1 / 2 / 3 / 4 cil. (66/72)		98,00		SL.1133..F STD 1	
D-225 (74/81)	Veicular	100,00		SL.1131..F STD 1	
D-225 (87/...)	Veicular	100,00		SL.1145..F STD 1	
D-229 (79/...)	Veicular, Agrícola, Industrial	102,00	3,00T 2,50 4,00	SL11291..F STD 1	K.62291 1 MK62291 1
D-229 (77/80)	Veicular	102,00		SL11291..F STD 1	
D-229 (81/84)	Veicular	102,00		SL11291..F STD 1	
D-229 (06/87...)		102,00		SL11291..F STD 1	



Linha de produtos Cofap Camisa e kit para motor



MARCA / MOTOR CILINDRO / ANO	MODELO	Ø		CAMISAS Medidas Cilindros por Embalagem	KIT COFAP Medidas Cilindros por Embalagem
MWM (cont.)					
TD-229 / 6 TD-229EC4 Turbo TD 229 EC 4/6	Estacionário/ Agrícola/ Marítimo/ Veicular	102,00	3,00T 2,50 4,00	SL11346..F STD 1	K.12346 1 (Pino 35mm) K.32346 1 (Pino 35mm) MK32346 1
D 229/6 (87/...)	Volks 11-140				K.22346 1
MWM 4.10 T / 4.10 TCA 4 cil. 6.10 TCA 6 cil.	Caminhão 7500/ 7500 VUC/ 6000 / 6000 VUC/ 8500/ 9200/ 7.5T/ 8.5T Pick-up F1000/ F4000/ VW8140/ VW8140 CO/ 9150 OD / 8150 OD / VW 12-140 Micro Ônibus - Vollare ÔNIBUS VW 16-18000 / VW 16-21000 / VW 17210 Euro I e Euro II	103,00	3,00T 2,50 4,00	SL11404..F STD 1	K.11404 1 MK11404 1
Motor Euro II 6.10TCA 6 cil.	17240 Protheus - 240cv	103,00	3,00T 2,50 4,00	SL11404..F STD 1	K.41404 1
6.10 TCW	Industrial , Marítimo	103,00	3,00T 2,50 4,00	SL11404..F STD 1	K.21404 1 MK21404 1
4.10NA / 6.10NA 4 / 6 cil	Caminhão 4500 D RS, 5000 RD, 5000 RS, 7000 7000 D		3,00T 2,50 4,00	SL11404..F STD 1	K.31404 1 MK31404 1
D-226 4 cil. (72/...)	Veicular Agrícola, Industrial, Veicular	105,00	3,00T 2,00 4,00	SL.1159 STD / 0,10" 0,20" / 0,30" 0,40" 1 SL.1159 STD / 0,10" 0,20" / 0,30" 0,40" 1	K.11411 1
Motor 4.12 TCE Acteon Euro III	Caminhão 8500 E-tronic / 9200 E-tronic MA7.5E-tronic / MA8.5E-tronic / MA9.2E-tronic Volare W8 / W9 Constellation 13.180/13.180E/15.180/15.180E	105,00	3,00 2,50 3,50		K.07001 1
PERKINS					
3-152 6 cil.		3.602" (91,49)		SL.1136 STD / .020"/ .030" 6	
4-203 Injeção Direta 3 / 4 / 6 cil.		3.602" (91,49)	3/32" 3/32" 1/8" 1/4" 1/4"	SL.1136 STD / .020" / .030" 6	K.21339 1
TQ-20B.4-236 TQ-20B.6-354 4 e 6 cil.	(85/...)	3.877" (98,47)		SL11294 STD s/ flange 4	
Q-20B 4236 4 cil. (68/...)		3.877" (98,47)	3,22T 2,43 4,80	SL11289 STD / .020" .030" / .040" 4 c/ flange	K.32343 1
4-236 / A.4-236 4 cil.	Agrícola , Industrial, Veicular	3.877" (98,47)	2,38 2,38 2,38 4,75 4,75	SL11289 STD / .020" .030" / .040" 4 c/ flange	K.11343 1



MARCA / MOTOR CILINDRO / ANO	MODELO	Ø		CAMISAS Medidas Cilindros por Embalagem	KIT COFAP Medidas Cilindros por Embalagem
PERKINS (cont.)					
T 4236 95 CV				3,32T 2,50 4,80	K.34343 1
Q20B 4236	Veicular			2,38 2,38 4,75	K.32343 1
Q20B 6354.4 Motor 6354.4 TW	Veicular, Agrícola			2,38 2,38 4,75	K.22343 1
Q-20B.4-236 Q-20B.6-354 Asp. Normal 4 cil. TQ-20B 6354.4 T 6354.4 6 cil.	Agrícola, Industrial, Veicular	3.877" (98,47)	3/32" 3/32" 3/16"	SL.11294 STD s/ flange 4	K.33294 1 K.44294 1
4-248 4 cil. (68/...)	Industrial , Veicular	3.9785" (101,05)		SL.1177 STD / .020" .030" / .040" 4	
6-357 6 cil. (66/82)	Agrícola, Industrial, Veicular	4.100" (104,14)	3/32" 3/32" 1/4" 1/4"	SL.1160 STD / .020" .030" 6	K.11340 1
6-357 6 cil. (66/82)		4.100" (104,14)		SL.1160 STD / .020" / .030" 6	
6-358 6 cil. (72/...)	Agrícola, Veicular	4.100" (104,14)	3/32" 3/32" 3/16" 3/16"	SL11283 STD / .020" / .030" / .040" 6	K.11283 1
PUMA					
MWM TD-229EC4 4 cil	Caminhão 9000	102,00	3,00T 2,50 4,00	SL11346..F STD 1	K.12346 1 (Pino 35mm)
D-229/4 4 cil.	Caminhão 914 Cabine Simples Caminhão 914 Cabine Dupla	102,00	3,00T 2,50 4,00	SL11291..F STD 1	K.62291 1 MK62291 1
RANDON					
Scania D-11	Caminhões Fora de Estrada RK-424	5" (127,00)	3/32" 3/32" 3/16"	SL.1235..F STD 1	K..2335 1
DS-11	Caminhões Fora de Estrada RK0424, RK-424 CM, RX-425	5" (127,00)	3/32" 3/32" 3/16" 3/32" 3/32" 3/16"	SL.1235..F STD 1	K..3335 1 K..5535 1 (1ª Canaleta trapezoidal)
Scania DS-14	Caminhão Fora de Estrada RK-435	5" (127,00)	3,50T 3/32" 3/16"	SL11348..F STD 1	K..11348 1
SCANIA					
D-11 / DS-11 (.../74)		5" (127,00)		SL.1130..F STD 1	
D / DN-11 (12/74 a 05/76)		5" (127,00)		SL.1130..F STD 1	
D-11 / DN-11 (06/76 a 05/82)		5" (127,00)	3/32" 3/32" 3/16"	SL.1235..F STD 1	K..2335 1



Linha de produtos Cofap Camisa e kit para motor



MARCA / MOTOR CILINDRO / ANO	MODELO	Ø		CAMISAS Medidas Cilindros por Embalagem	KIT COFAP Medidas Cilindros por Embalagem
SCANIA (cont.)					
DS-11 / DSC-11 DSI-11 (.../89)		5" (127,00)	3/32" 3/32" 3/16"	SL.1130..F STD 1	
DS-11 / DSC-11 DSI-11 (06/76 a 05/82)	Veicular / Marítimo	5" (127,00)	3/32" 3/32" 3/16" 3/32" 3/32" 3/16"	SL.1235..F STD 1	K..3335 1 K..5535 1 (1ª canaleta trapezoidal)
DS-11 / DSC-11 DSI-11		5" (127,00)	2,38 2,38 4,75	SL.1235..F STD 1	K..4435 1 HC - 0,4 mm
DS-14 / DSC-14 DSI-14 (.../89) 6 / 8 cil		5" (127,00)	3,50T 3/32" 3/16"	SL11348..F STD 1	K.11348 1
DSC-11 DS-11 DSI-11 6 cil. Série 113 (90/...)	Veicular, Marítimo, Estacionário	5" (127,00)	3,50T 3/32" 3/16"	SL11409..F STD 1	K.11409 1 K.21409 1 HC - 0,4 mm
DSC-12 Série 4 Articulado 420 CV 6 cil.	Veicular, Marítimo, Estacionário	5" (127,00)	3,50 2,39 3,50		K.06003 1
D-112 (06.82 a 89)		5" (127,00)		SL11430..F STD 1	
DS /DSC / DSI-112 Caminhão 113 H (95/...)		5" (127,00)	3,50T 3/32" 3/16"	SL11511..F STD 1	K.11511 1
Motor DSC12 Série 4 360 e 400CV 6 cil.	P 124, R 124, T 124, K 124	5" (127,00)	3,50 2,39 3,50		K.06001 1
DSC 11 Série 114 6 cil.		5" (127,00)	3,50 2,39 3,50		K.06002 1
VOLKSWAGEN					
Perkins Q-20B.4-236	Caminhão-6.80 (82 /...) 6-90 / 7-90 P	3.877" (98,47)	3/32" 3/32" 3/16"	SL11294 STD 4	K.33294 1
MWM TD-229 EC	Caminhão 7.90 S, 7110 S	102,00		SL11346..F STD 1	K.12346 1 (Pino 35mm)
MWM D-229 4 / 6 cil.	Caminhão 6-90, 7-90, 7-90S	102,00	3,00T 2,50 4,00	SL11291..F STD 1	K.62291 1 MK62291 1
MWM D-229 6 cil.	Caminhão 11.130, 13.130, 11-140, 12.140N, 14-140, 22.140 (06/87...)	102,00		SL11291..F STD 1	
MWM 4.10 / 6.10 Aspirado/Turbinado 4 / 6 cil.	Caminhão 8-120 / 8-140 / 8-150 / 12-140 Ônibus 8-140 CO/16-180 CO / 16-210 CO	103,00	3,00T 2,50 4,00	SL11404..F STD 1	K.11404 1
MWM 4.10 / 6.10 Aspirado/Turbinado 4 / 6 cil.	Caminhão 7-100 / 14-150 / 17-210 17-240 4X2 /	103,00		SL11404..F STD 1	K.31404 1 MK31404 1
Motor 4.12 TCE Acteon Euro III	Constellation 13.180 / 13.180E / 15.180 / 15.180E	105,00	3,00 2,50 3,50		K.07001 1















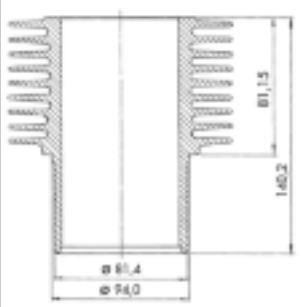

MARCA / MOTOR CILINDRO / ANO	MODELO	Ø		CAMISAS Medidas Cilindros por Embalagem	KIT COFAP Medidas Cilindros por Embalagem
VOLVO					
THD-100/EC/ EB / GB / GC / GD	Ônibus B-58 E (84/...)	4 3/4" (120,65)	3/32" 1/8" 3/16"		K.41367 1
THD-101KC, GB, GC, GP	Ônibus B-10 M				
TD-100 G, TD-101 G, TD-101 F, TD-101 G	Caminhão N-10 Caminhão NL-10.280		3/32" 1/8" 3/16"		K.31367 1
TD102FS	Caminhão NL 10340 Articulado	4 3/4" (120,65)	3,00 3,16 4,74		K.19002 1
TD10A		120,64	4,00 3,16 4,75		K.19001 1
D 12 C/D 99/05 NH 12 380CV NH 12 380CV 99/... FH12 380CV 03/... Articulado		131,00	4,00 3,00 4,00		K.19003 1

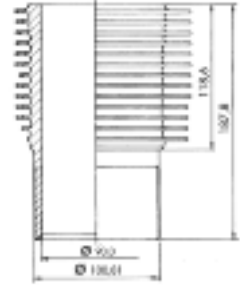
linha de
produtos

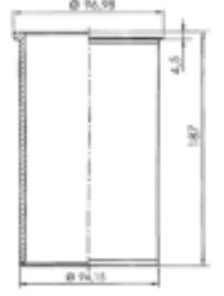
Xeotrap

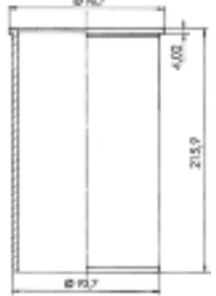
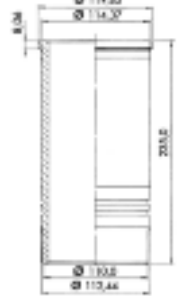
informações técnicas
**camisa e kit
para motor**













MARCA	Ø	CAMISAS Medidas			MARCA	Ø	CAMISAS Medidas		
AGRALE	73,00	SL.1229..F STD		6	MBB	97,00	SL.1153 STD / .020" / .030" / .040" / .050" / .060" / .080" / 0.1"		6
AGRALE	90,00	SL.1174..F STD		1	MBB	97,00	SL11366 STD / .020" S/ FLANGE		6
MBB	90,49	SL11546 STD		4	MBB	97,00	SL11485 STD/.020" Pré-Mandrilada		6
PERKINS	91,49	SL.1136 STD / .020" / .030"		6	MWM	98,00	SL.1133..F STD		1
MWM	93,00	SL11592 STD		4	PERKINS	98,47	SL11289 STD / .020" .030" / .040"		4
MBB	95,00	SL..111 STD / .020"		6	PERKINS	98,47	SL11294 STD / .020" / .030" / .040" S/ FLANGE		4

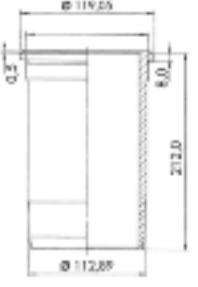
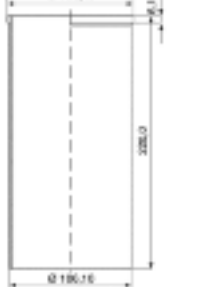
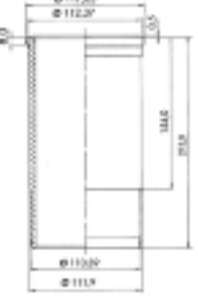
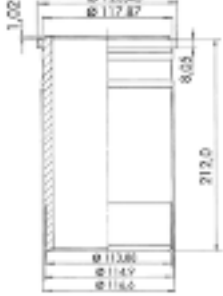

Linha de produtos Cofap
Camisa e kit para motor
DESENHOS TÉCNICOS

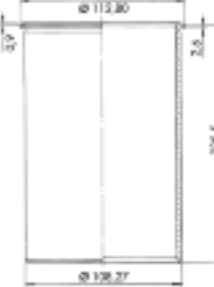
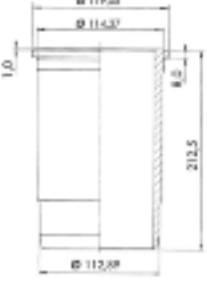

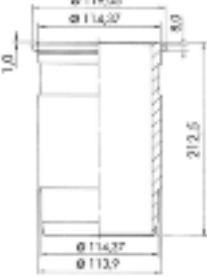
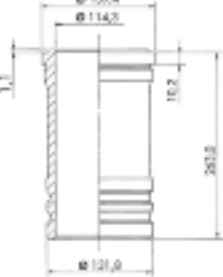
MARCA	Ø	CAMISAS Medidas			MARCA	Ø	CAMISAS Medidas		
MWM	100,00	SL.1131..F STD		1	MBB	102,00	SL.11924 STD		4
MWM	100,00	SL.1145..F STD		1	MWM	103,00	SL.11404..F STD		1
MAXION	100,00	SL.11390 STD / .020"		4	PERKINS	104,14	SL.1160 STD / .020" / .030"		6
PERKINS	101,05	SL.1177 STD / .020" .030" / .040"		4	PERKINS	104,14	SL.11283 STD / .020" / .030" / .040"		6
MWM	102,00	SL.11291..F STD		1	MWM	105,00	SL.1159 STD / .010" .020" / .030" / .040"		1
MWM	102,00	SL.11346..F STD		1	CATERPILLAR	114,3	SL.1113..F STD		1



Linha de produtos Cofap
Camisa e kit para motor
DESENHOS TÉCNICOS



MARCA	Ø	CAMISAS Medidas			MARCA	Ø	CAMISAS Medidas		
CATERPILLAR	120,65	SL11296..F STD		1	SCANIA	127,00	SL11494..F STD		1
SCANIA	127,00	SL.1130..F STD		1	SCANIA	127,00	SL11511..F STD		2
SCANIA	127,00	SL.1235..F STD		1	MBB	128,00	SL11363 STD / .010"/ .020"/ .030"/ .040"		6
SCANIA	127,00	SL11348..F STD		1	MBB	128,00	SL11419..F STD		1
SCANIA	127,00	SL11409..F STD		1	MBB	128,00	SL11852..F STD		1
SCANIA	127,00	SL11430..F STD		1	CATERPILLAR	146,05	SL.1207..F STD		1



Linha de produtos Cofap
Camisa e kit para motor



camisa e kit para motor

CÓDIGO COFAP	MONTADORA	CÓDIGO COFAP	MONTADORA	CÓDIGO COFAP	MONTADORA	CÓDIGO COFAP	MONTADORA
--------------	-----------	--------------	-----------	--------------	-----------	--------------	-----------

LISTA NUMÉRICA

KITS PARA MOTOR		CÓDIGO COFAP	MONTADORA	CÓDIGO COFAP	MONTADORA	CÓDIGO COFAP	MONTADORA
K..1113	CATERPILLAR	K.15015	CUMMINS	SL..111.20	MBB	SL11363.30	MBB
K..1145	MWM	K.15016	CUMMINS	SL.1113..F	CATERPILLAR	SL11363.40	MBB
K..2335	SCANIA	K.15017	CUMMINS	SL.1130..F	SCANIA	SL11366	MBB
K..3335	SCANIA	K.19001	VOLVO	SL.1131..F	MWM	SL11366.20	MBB
K..4435	SCANIA	K.19002	VOLVO	SL.1133..F	MWM	SL11390	MAXION
K..5535	SCANIA	K.19003	VOLVO	SL.1136	PERKINS	SL11390.20	MAXION
K.06001	SCANIA	K.21339	PERKINS	SL.1136.20	PERKINS	SL11404..F	MWM
K.06002	SCANIA	K.21390	PERKINS	SL.1136.30	PERKINS	SL11409..F	SCANIA
K.06003	SCANIA	K.21402	FORD	SL.1145..F	MWM	SL11419..F	MBB
K.07001	MWM	K.21404	MWM	SL.1153	MBB	SL11430..F	SCANIA
K.11001	CATERPILLAR	K.21409	SCANIA	SL.1153.20	MBB	SL11494..F	SCANIA
K.11002	CATERPILLAR	K.21419	MBB	SL.1153.30	MBB	SL11511..F	SCANIA
K.11003	CATERPILLAR	K.21592	MWM	SL.1153.40	MBB	SL11521..F	PEUGEOT
K.11004	CATERPILLAR	K.22153	MBB	SL.1153.50	MBB	SL1153.100	MBB
K.11153	MBB	K.22254	CATERPILLAR	SL.1153.60	MBB	SL11546	MBB
K.11283	PERKINS	K.22296	CATERPILLAR	SL.1153.80	MBB	SL11592	MWM
K.11339	PERKINS	K.22341	PERKINS	SL.1159	MWM	SL11852..F	MBB
K.11340	PERKINS	K.22343	PERKINS	SL.1159.10	MWM	SL11924	MBB
K.11341	PERKINS	K.22346	MWM	SL.1159.20	MWM		
K.11343	PERKINS	K.22390	PERKINS	SL.1159.30	MWM		
K.11348	SCANIA	K.22546	PERKINS	SL.1159.40	MWM		
K.11390	PERKINS	K.31367	VOLVO	SL.1160	PERKINS		
K.11402	FORD	K.31404	MWM	SL.1160.20	PERKINS		
K.11404	MWM	K.31592	MWM	SL.1160.30	PERKINS		
K.11409	SCANIA	K.32343	PERKINS	SL.1174..F	AGRALE		
K.11411	MWM	K.32346	MWM	SL.1177	PERKINS		
K.11419	MBB	K.32390	PERKINS	SL.1177.20	PERKINS		
K.11455	FORD/VW	K.33153	MBB	SL.1177.30	PERKINS		
K.11494	SCANIA	K.33294	PERKINS	SL.1177.40	PERKINS		
K.11511	SCANIA	K.33296	CATERPILLAR	SL.1207..F	CATERPILLAR		
K.11546	PERKINS	K.33343	PERKINS	SL.1212	FORD TRATORES		
K.11592	MWM	K.33390	PERKINS	SL.1212.20	FORD TRATORES		
K.11852	MBB	K.34343	PERKINS	SL.1229..F	AGRALE		
K.11924	MBB	K.41367	VOLVO	SL.1235..F	SCANIA		
K.12254	CATERPILLAR	K.41404	MWM	SL.1276..F	YANMAR		
K.12296	CATERPILLAR	K.42390	PERKINS	SL11283	PERKINS		
K.12346	MWM	K.43153	MBB	SL11283.20	PERKINS		
K.12924	MBB	K.43294	PERKINS	SL11283.30	PERKINS		
K.15001	CUMMINS	K.44153	MBB	SL11283.40	PERKINS		
K.15002	CUMMINS	K.44294	PERKINS	SL11289	PERKINS		
K.15003	CUMMINS	K.44296	CATERPILLAR	SL11289.20	PERKINS		
K.15004	CUMMINS	K.47001	VALMET / VALTRA	SL11289.30	PERKINS		
K.15005	CUMMINS	K.52390	PERKINS	SL11289.40	PERKINS		
K.15006	CUMMINS	K.54153	MBB	SL11291..F	MWM		
K.15007	CUMMINS	K.55153	MBB	SL11294	PERKINS		
K.15008	CUMMINS	K.55296	CATERPILLAR	SL11294.20	PERKINS		
K.15009	CUMMINS	K.56153	MBB	SL11294.30	PERKINS		
K.15010	CUMMINS	K.62291	MWM	SL11294.40	PERKINS		
K.15011	CUMMINS	K.64153	MBB	SL11296..F	CATERPILLAR		
K.15012	CUMMINS	K.66153	MBB	SL11346..F	MWM		
K.15013	CUMMINS	K.67153	MBB	SL11348..F	SCANIA		
K.15014	CUMMINS			SL11363	MBB		
				SL11363.10	MBB		
				SL11363.20	MBB		

CAMISAS PRÉ-MANDRILADAS

SL11485	MBB
SL11485.20	MBB

MAXI KIT COFAP

MK11404	MWM
MK21404	MWM
MK31404	MWM
MK62291	MWM
MK32346	MWM

CAMISAS DE CLINDROS

SL..111	MBB
---------	-----



TABELA DE CONVERSÃO

MILIMETERS - DECIMAL INCHES
MILLIMETRI - POLLICI
MILIMETROS - PULGADAS

mm	"	mm	"	mm	"
0,001	.000039	0,1	.00394	10	.39370
0,002	.000079	0,2	.00787	11	.43307
0,003	.000118	0,3	.01181	12	.47244
0,004	.000157	0,4	.01575	13	.51181
0,005	.000197	0,5	.01969	14	.55118
0,006	.000236	0,6	.02362	15	.59055
0,007	.000276	0,7	.02756	16	.62992
0,008	.000315	0,8	.03150	17	.66929
0,009	.000354	0,9	.03543	18	.70866
0,010	.00039	1	.03937	19	.74803
0,02	.00079	2	.07874	20	.7874
0,03	.00118	3	.11811	30	1,1811
0,04	.00157	4	.15748	40	1,5748
0,05	.00197	5	.19685	50	1,96850
0,06	.00236	6	.23622	60	2,36220
0,07	.00276	7	.27559	70	2,75590
0,08	.00315	8	.31496	80	3,14960
0,09	.00354	9	.35433	90	3,54330

Example: 73,832 mm - inches / pollici / pulgadas

Esempio:

70,0	-	2,7559
3,0	-	0,11811
0,8	-	0,03150
0,03	-	0,00118
0,002	-	0,000079
73,832	-	2,90677"

1" = 25,40000 mm

1 mm = 0,039370"

DECIMAL INCHES - MILIMETERS
POLLICI - MILLIMETRI
PULGADAS - MILIMETROS

"	mm	"	mm	"	mm
.0001	.00254	.010	.254	1	25,4
.0002	.00508	.020	.508	2	50,8
.0003	.00762	.030	.762	3	76,2
.0004	.01016	.040	1,016	4	101,6
.0005	.01270	.050	1,270	5	127,0
.0006	.01524	.060	1,524	6	152,4
.0007	.01778	.070	1,778	7	177,8
.0008	.02032	.080	2,032	8	203,2
.0009	.02286	.090	2,286	9	228,6
.0010	.0254	1	2,54	10	254,0
.002	.0508	2	5,08	20	508,0
.003	.0762	3	7,62	30	762,0
.004	.1016	4	10,16	40	1016
.005	.1270	5	12,70	50	1270
.006	.1524	6	15,24	60	1524
.007	.1778	7	17,78	70	1778
.008	.2032	8	20,32	80	2032
.009	.2286	9	22,86	90	2286

2,573" - mm

2,0000	-	50,80
.5000	-	12,70
.0700	-	1,778
.0040	-	0,1016
.0003	-	0,00762
2.5743	-	65,3872 mm



TABELA DE CONVERSÃO

1" = 25,40000 mm

1 mm = 0,039370"

FRACTION FRAZIONE FRACCIÓN		inches / pollici / pulgadas											
		0"	1"	2"	3"	4"	5"	6"	7"	8"	9"	10"	11"
		milimeters / milimetri / milímetros											
0	.0	0	25,400 0	50,800 0	76,200 0	101,600 0	127,000 0	152,400 0	177,800 0	203,200 0	228,600 0	254,000 0	279,400 0
1/64	.015625	0,396 9	25,796 9	51,193 8	76,590 7	101,987 6	127,384 5	152,781 4	178,178 3	203,575 2	228,972 1	254,369 0	279,766 9
1/32	.03125	0,793 8	26,193 8	51,593 8	76,993 8	102,393 8	127,793 8	153,193 8	178,593 8	203,993 8	229,393 8	254,793 8	280,193 8
3/64	.046875	1,190 6	26,590 6	51,990 6	77,390 6	102,790 6	128,190 6	153,590 6	178,990 6	204,390 6	229,790 6	255,190 6	280,590 6
1/16	.062 5	1,587 5	26,987 5	52,387 5	77,787 5	103,187 5	128,587 5	153,987 5	179,387 5	204,787 5	230,187 5	255,587 5	280,987 5
5/64	.078125	1,984 4	27,384 4	52,784 4	78,184 4	103,584 4	128,984 4	154,384 4	179,784 4	205,184 4	230,584 4	255,984 4	281,384 4
3/32	.09375	2,381 2	27,781 2	53,181 2	78,581 2	103,981 2	129,381 2	154,781 2	180,181 2	205,581 2	230,981 2	256,381 2	281,781 2
7/64	.109375	2,778 1	28,178 1	53,578 1	78,978 1	104,378 1	129,778 1	155,178 1	180,578 1	205,978 1	231,378 1	256,778 1	282,178 1
1/8	.125	3,175 0	28,575 0	53,975 0	79,375 0	104,775 0	130,175 0	155,575 0	180,975 0	206,375 0	231,775 0	257,175 0	282,575 0
9/64	.140625	3,571 9	28,971 9	54,371 9	79,771 9	105,171 9	130,571 9	155,971 9	181,371 9	206,771 9	232,171 9	257,571 9	282,971 9
5/32	.15625	3,968 8	29,368 8	54,768 8	80,168 8	105,568 8	130,968 8	156,368 8	181,768 8	207,168 8	232,568 8	257,968 8	283,368 8
11/64	.171875	4,365 6	29,765 6	55,165 6	80,565 6	105,965 6	131,365 6	156,765 6	182,165 6	207,565 6	232,965 6	258,365 6	283,765 6
3/16	.187 5	4,762 5	30,162 5	55,562 5	80,962 5	106,362 5	131,762 5	157,162 5	182,562 5	207,962 5	233,362 5	258,762 5	284,162 5
13/64	.203125	5,159 4	30,559 4	55,959 4	81,359 4	106,759 4	132,159 4	157,559 4	182,959 4	208,359 4	233,759 4	259,159 4	284,559 4
7/32	.21875	5,556 2	30,956 2	56,356 2	81,756 2	107,156 2	132,556 2	157,956 2	183,356 2	208,756 2	234,156 2	259,556 2	284,956 2
15/64	.234375	5,953 1	31,353 1	56,753 1	82,153 1	107,553 1	132,953 1	158,353 1	183,753 1	209,153 1	234,553 1	259,953 1	285,353 1
1/4	.25	6,350 0	31,750 0	57,150 0	82,550 0	107,950 0	133,350 0	158,750 0	184,150 0	209,550 0	234,950 0	260,350 0	285,750 0
17/64	.265625	6,746 9	32,146 9	57,546 9	82,946 9	108,346 9	133,746 9	159,146 9	184,546 9	209,946 9	235,346 9	260,746 9	286,146 9
9/32	.28125	7,143 8	32,543 8	57,943 8	83,343 8	108,743 8	134,143 8	159,543 8	184,943 8	210,343 8	235,743 8	261,143 8	286,543 8
19/64	.296875	7,540 6	32,940 6	58,340 6	83,740 6	109,140 6	134,540 6	159,940 6	185,340 6	210,740 6	236,140 6	261,540 6	286,940 6
5/16	.3125	7,937 5	33,337 5	58,737 5	84,137 5	109,537 5	134,937 5	160,337 5	185,737 5	211,137 5	236,537 5	261,937 5	287,337 5
21/64	.328125	8,334 4	33,734 4	59,134 4	84,534 4	109,934 4	135,334 4	160,734 4	186,134 4	211,534 4	236,934 4	262,334 4	287,734 4
11/32	.34375	8,731 2	34,131 2	59,531 2	84,931 2	110,331 2	135,731 2	161,131 2	186,531 2	211,931 2	237,331 2	262,731 2	288,131 2
23/64	.359375	9,128 1	34,528 1	59,928 1	85,328 1	110,728 1	136,128 1	161,528 1	186,928 1	212,328 1	237,728 1	263,128 1	288,528 1
3/8	.375	9,525 0	34,925 0	60,325 0	85,725 0	111,125 0	136,525 0	161,925 0	187,325 0	212,725 0	238,125 0	263,525 0	288,925 0
25/64	.390625	9,921 9	35,321 9	60,721 9	86,121 9	111,521 9	136,921 9	162,321 9	187,721 9	213,121 9	238,521 9	263,921 9	289,321 9
13/32	.40625	10,318 8	35,718 8	61,118 8	86,518 8	111,918 8	137,318 8	162,718 8	188,118 8	213,518 8	238,918 8	264,318 8	289,718 8
27/64	.421875	10,715 6	36,115 6	61,515 6	86,915 6	112,315 6	137,715 6	163,115 6	188,515 6	213,915 6	239,315 6	264,715 6	290,115 6
7/16	.4375	11,112 5	36,512 5	61,912 5	87,312 5	112,712 5	138,112 5	163,512 5	188,912 5	214,312 5	239,712 5	265,112 5	290,512 5
29/64	.453125	11,509 4	36,909 4	62,309 4	87,709 4	113,109 4	138,509 4	163,909 4	189,309 4	214,709 4	240,109 4	265,509 4	290,909 4
15/32	.46875	11,906 2	37,306 2	62,706 2	88,106 2	113,506 2	138,906 2	164,306 2	189,706 2	215,106 2	240,506 2	265,906 2	291,306 2
31/64	.484375	12,303 1	37,703 1	63,103 1	88,503 1	113,903 1	139,303 1	164,703 1	190,103 1	215,503 1	240,903 1	266,303 1	291,703 1
1/2	.5	12,700 0	38,100 0	63,500 0	88,900 0	114,300 0	139,700 0	165,100 0	190,500 0	215,900 0	241,300 0	266,700 0	292,100 0
33/64	.515625	13,096 9	38,496 9	63,896 9	89,296 9	114,696 9	140,096 9	165,496 9	190,896 9	216,296 9	241,696 9	267,096 9	292,496 9
17/32	.53125	13,493 8	38,893 8	64,293 8	89,693 8	115,093 8	140,493 8	165,893 8	191,293 8	216,693 8	242,093 8	267,493 8	292,893 8
35/64	.546875	13,890 6	39,290 6	64,690 6	90,090 6	115,490 6	140,890 6	166,290 6	191,690 6	217,090 6	242,490 6	267,890 6	293,290 6
9/16	.562 5	14,287 5	39,687 5	65,087 5	90,487 5	115,887 5	141,287 5	166,687 5	192,087 5	217,487 5	242,887 5	268,287 5	293,687 5
37/64	.578125	14,684 4	40,084 4	65,484 4	90,884 4	116,284 4	141,684 4	167,084 4	192,484 4	217,884 4	243,284 4	268,684 4	294,084 4
19/32	.59375	15,081 2	40,481 2	65,881 2	91,281 2	116,681 2	142,081 2	167,481 2	192,881 2	218,281 2	243,681 2	269,081 2	294,481 2
39/64	.609375	15,478 1	40,878 1	66,278 1	91,679 1	117,078 1	142,478 1	167,878 1	193,278 1	218,678 1	244,078 1	269,478 1	294,878 1
5/8	.625	15,875 0	41,275 0	66,675 0	92,075 0	117,475 0	142,875 0	168,275 0	193,675 0	219,075 0	244,475 0	269,875 0	295,275 0
41/64	.640625	16,271 9	41,671 9	67,071 9	92,471 9	117,871 9	143,271 9	168,671 9	194,071 9	219,471 9	244,871 9	270,271 9	295,671 9
21/32	.65625	16,668 8	42,068 8	67,468 8	92,868 8	118,268 8	143,668 8	169,068 8	194,468 8	219,868 8	245,268 8	270,668 8	296,068 8
43/64	.671875	17,065 6	42,465 6	67,865 6	93,265 6	118,665 6	144,065 6	169,465 6	194,865 6	220,265 6	245,665 6	271,065 6	296,465 6
11/16	.687 5	17,462 5	42,862 5	68,262 5	93,662 5	119,062 5	144,462 5	169,862 5	195,262 5	220,662 5	246,062 5	271,462 5	296,862 5
45/64	.703125	17,859 4	43,259 4	68,659 4	94,059 4	119,459 4	144,859 4	170,259 4	195,659 4	221,059 4	246,459 4	271,859 4	297,259 4
23/32	.71875	18,256 2	43,656 2	69,056 2	94,456 2	119,856 2	145,256 2	170,656 2	196,056 2	221,456 2	246,856 2	272,256 2	297,656 2
47/64	.734375	18,653 1	44,053 1	69,453 1	94,853 1	120,253 1	145,653 1	171,053 1	196,453 1	221,853 1	247,253 1	272,653 1	298,053 1
3/4	.75	19,050 0	44,450 0	69,850 0	95,250 0	120,650 0	146,050 0	171,450 0	196,850 0	222,250 0	247,650 0	273,050 0	298,450 0
49/64	.765625	19,446 9	44,846 9	70,246 9	95,646 9	121,046 9	146,446 9	171,846 9	197,246 9	222,646 9	248,046 9	273,446 9	298,846 9
25/32	.78125	19,843 8	45,243 8	70,643 8	96,043 8	121,443 8	146,843 8	172,243 8	197,643 8	223,043 8	248,443 8	273,843 8	299,243 8
51/64	.796875	20,240 6	45,640 6	71,040 6	96,440 6	121,840 6	147,240 6	172,640 6	198,040 6	223,440 6	248,840 6	274,240 6	299,640 6
13/16	.812 5	20,637 5	46,037 5	71,437 5	96,837 5	122,237 5	147,637 5	173,037 5	198,437 5	223,837 5	249,237 5	274,637 5	300,037 5
53/64	.828125	21,034 4	46,434 4	71,834 4	97,234 4	122,634 4	148,034 4	173,434 4	198,834 4	224,234 4	249,634 4	275,034 4	300,434 4
27/32	.84375	21,431 2	46,831 2										

MAGNETI

linha de produtos

Magneti Magneti

LINHA DE PRODUTOS MAGNETI MARELLI

BATERIA PARA CAMINHÕES E ÔNIBUS

Agrale, Chrysler, Ford, General Motors-Chevrolet, Iveco, Mercedes-Benz.....	98
Scania, Volkswagen.....	99
Volvo.....	100
Características técnicas e cuidados especiais.....	101

BATERIA PARA MÁQUINAS AGRÍCOLAS, EMPILHADEIRAS E TERRAPLANAGEM

AGCO-Massey Ferguson, Agrale tratores, Case (J. J. Case), Caterpillar, Clark tratores, Engesa.....	102
Fiat Allis, Huber Wabco/ Dresser, John Deere, Komatsu, Malves, Müller, New Holland.....	103
Poclain, Randon, Svedala Dynapac, Tema Terra, Terex, Valmet/ Valtra.....	104
Volvo Construction Equipament, Wabco, Yale, Zector.....	104
Cross reference.....	105
Procedimentos de recarga.....	106

BOMBA D'ÁGUA

AGCO.....	108
Agrale, Case, CBT.....	109
Chevrolet.....	110
Clark, Dynapac.....	111
Fiat Allis, Ford.....	112
Hyster, Ideal, JI Case, Marcoplan.....	115
Massey Ferguson, Maxion, Mercedes-Benz.....	116
MWM, Perkins.....	124
Scania, Valmet.....	125
Volkswagen.....	127

BOMBA D'ÁGUA PREMIUM

Iveco, Scania.....	130
--------------------	-----

BOMBA DE ÓLEO PREMIUM

Iveco, MWM.....	130
-----------------	-----

COMPRESSOR

Iveco, Scania, Volvo.....	130
---------------------------	-----

CORREIA AUTOMOTIVA PARA CAMINHÕES

Agrale, Fiat, Ford, General Motors.....	133
International, Iveco, Mercedes-Benz.....	134
Scania.....	135
Volkswagen.....	136

CORREIA AUTOMOTIVA PARA ÔNIBUS

Agrale, Ford, Mercedes-Benz.....	139
Scania, Volare.....	140
Volkswagen, Volvo.....	141

CORREIA AUTOMOTIVA PARA MÁQUINAS E IMPLEMENTOS AGRÍCOLAS

Agrale, Baber Greene, Caterpillar, CBT, Claas Consul, Clark Consul.....	143
Clayson Consul, Cummins Motors, Eaton, Fiat Allis, Ford, Hyster.....	144
Ideal Standard, Komatsu, Lavrale, Massey Ferguson.....	145
Müller, MWM, New Holland, Santa Matilde, Schneider Logemann, SLS John Deere, Sperry New Holland, Tema-Terra.....	146
Terex, Valmet, Valtra Valmet, Yanmar Valmet.....	147

FILTRO DE AR, ÓLEO, CABINE E COMBUSTÍVEL - CAMINHÕES E ÔNIBUS

Agrale.....	150
Clark, Fiat.....	151
Ford.....	152
General Motors.....	158
Iveco.....	159
Maferesa, Matra, Mercedes-Benz.....	160
Puma, Randon, Santa Matilde, Scania.....	171
Volvo.....	175
Volkswagen.....	179

LÂMPADAS AUTOMOTIVAS

Agrale, Ford, Iveco, Kia Motors, Mercedes-Benz.....	189
Peugeot, Renault, Scania.....	193
Volkswagen.....	194
Volvo.....	195
Índices de bases.....	196

MÁQUINA ROTANTE

Designações de terminais.....	198
Regulador de voltagem.....	199
Designações de terminais.....	208
Retificador.....	209
Designações de terminais.....	218
Módulo de Ignição.....	219

LINHA TÉRMICA

Ford, Iveco, Mercedes-Benz/ Daimler Chrysler.....	223
Scania.....	225
Volkswagen, Volvo.....	226
Desenhos Técnicos.....	230

VÁLVULA TERMOSTÁTICA

Caterpillar, Cummins.....	244
Mercedes-Benz, MWM, Scania.....	245
Volkswagen, Volvo.....	246
Guia e consulta.....	246

linha de
produtos

MAGNET
MARELL

bateria



Linha de produtos Magneti Marelli
Bateria para caminhões e ônibus



MARCA/ MODELO		DIESEL		
		PLUS	PESADA	PESADA SPA

AGRALE

1600 ÔNIBUS/ FURGÃO	Todos		PL100ER	
1800 DW	88/		PL150LA	SP150LR
4000/ 4200/ 4500/ 5000/ 7000/ 7500/ 8500	Todos		PL150LA	SP150LR
6000/ 8500	02/		PL100ER	
TX 1200	Todos	PL60ERH		
TX 1600	83/ 90		PL100ER	
TX 1600	91/		PL150LA	SP150LR
VOLARE	02/		PL100ER	
VOLARE W8/ W9	08/	PL70ERS		

CHRYSLER

E11/ E13/ E21	82/ 85		PL100ER	ANO
---------------	--------	--	---------	-----

FORD

CARGO 712/ 814/ 815	Todos		PL100ER	
CARGO 1113/ 1114/ 1117/ 1215/ 1217/ 1218/ 1313/ 1314/ 1317	Todos		PL150LA / PL150LR	SP150LR
CARGO 1415/ 1417/ 1418/ 1419/ 1421/ 1514/ 1517/ 1521	Todos		PL150LA / PL150LR	SP150LR
CARGO 1615/ 1617/ 1618/ 1619/ 1621/ 1622/ 1630	Todos		PL150LA / PL150LR	SP150LR
CARGO 2319/ 2322/ 2324/ 2421/2422/ 2425/ 2428	Todos		PL150LA / PL150LR	SP150LR
CARGO 2622/ 2626/ 2628/ 2630/ 2631/ 2632/ 2831/ 2932	Todos		PL150LA / PL150LR	SP150LR
CARGO 3222/ 3224/ 3530	Todos		PL150LA / PL150LR	SP150LR
CARGO 4030/ 4031/ 4331/ 4532e	Todos		PL100ERS	
F2000/ F4000	75/ 93		PL150LA / PL150LR	SP150LR
F4000	94/ 03		PL100ERS	
F4000	04/	PL70ERS		
F600/ F700	80/		PL150LA / PL150LR	SP150LR
FORD CARGO	85/ 90		PL100ERS	

GENERAL MOTORS - CHEVROLET

12-170/ 12-190/ 14-190/ 15-190/ 16-220	/99		PL100ERP	
5-90/ 6-100/ 6-150/ 7-110	/99	PL70ERS		
A10/ A20/ A40/ A60/ A70/ A80/ A90	81/	PL60DRH		
AC99 CANAVIEIRO	85/	PL70DR		
D11.000/ D12.000/ D14.000	Todos		PL170TD / PL170LR	
D6000	Todos	PL60ERH		
GMC 12170, 14190 E 16220 - Todos	97/		PL100ERS	

IVECO

CAVALLINO	Todos		PL100ERS	
DAILY	Todos	PL90DR		
EUROCARGO	Todos		PL100ERS	
EUROTECH	Todos		PL150LAS / PL150LRS	
EUROTRAKKER	Todos		PL150LAS / PL150LRS	
SCUDATO	Todos	PL90DR		
STRALIS	Todos		PL150LAS / PL150LRS	

MERCEDES-BENZ

SÉRIE 700: 709/ 710	Todos		PL100ER	
SÉRIE 700: 712 C	Todos		PL100ERS	
SÉRIE 800: 812/ 814	Todos		PL150LA / PL150LR	SP150LR
SÉRIE 900: 912/ 914/ 915 (MECÂNICO)	Todos		PL150LA / PL150LR	
SÉRIE 900: 914 C/ 915 C (ELETRÔNICO)	Todos		PL100ERS	
SÉRIE 1200: 1214/1214 C/1218	Todos		PL100ER	
SÉRIE 1200: 1215 C/ 1218 EL	Todos		PL100ERS	
SÉRIE 1300: 1318	Todos		PL100ERS	
SÉRIE 1400: 1417/ 1418 C/ 1420	Todos		PL150LAS / PL150LRS	SP150LR
SÉRIE 1400: 1414/ 1418	Todos		PL100ER	



Linha de produtos Magneti Marelli
Bateria para caminhões e ônibus



MARCA/ MODELO		DIESEL		
		PLUS	PESADA	PESADA SPA
MERCEDES-BENZ (cont.)				
SÉRIE 1500: 1518	Todos		PL150LA / PL150LR	SP150LR
SÉRIE 1500: 1518 C	Todos		PL150LAS / PL150LRS	SP150LR
SÉRIE 1600: 1614/ 1618/ 1620/ 1621/ 1622/ 1624/ 1615	Todos		PL100ER	
SÉRIE 1600: 1630/ 1632	Todos		PL150LA / PL150LR	
SÉRIE 1600: LS 1634	Todos		PL150LAS / PL150LRS	
SÉRIE 1600: 1620/ 1621/ 1623/ 1628/ 1635	Todos		PL100ER	
SÉRIE 1700: 1714/ 1718/ 1720/ 1721/ 1723/ 1728/ 1741	Todos		PL100ER	
SÉRIE 1700: 1718/ 1722	Todos		PL100ERS	
SÉRIE 1900: 1938/ 1944	Todos		PL150LAS / PL150LRS	
SÉRIE 1900: 1935/1941	Todos		PL150LA / PL150LR	
SÉRIE 2300: 2314/ 2316/ 2318/ 2325	Todos		PL100ER	
SÉRIE 2400: 2414/ 2416/ 2418	Todos		PL100ER	
SÉRIE 2400: 2423/ 2425/ 2428	Todos		PL100ERS	
SÉRIE 2600: 2635/ 2638	Todos		PL150LAS / PL150LRS	
SÉRIE 2700: 2726	Todos		PL100ERS	
2831	Todos		PL150LAS / PL150LRS	
ACCELO: 715C/ 915C (ELETRÔNICO)	Todos		PL100ERS	
ATEGO (ELETRÔNICO) 1315/ 1418/ 1518/ 1718/ 1725/ 1728/ 2415/ 2425/ 2428	Todos		PL100ERS	
912-9 (BATERIA DENTRO DA CABINE)	Todos		PL150LAS / PL150LRS	
AXOR Rodoviário - 1933 / 2035 / 2040 / 2044/ 2533/ 2540/ 2544/ 2640/ 2644 (TODOS)	Todos		PL150LAS / PL150LRS	
AXOR Fora de Estrada - 2826/ 2831/ 3340/ 3344/ 4140/ 4144	Todos		PL150LAS / PL150LRS	
L-709/ 912, LS-1934	88/		PL150LA / PL150LR	
LA, LP, LPO - 1113	69/86		PL150LA / PL150LR	SP150LR
LAK-1118 / 1314 / 1514 / 2014 / 2214	87/		PL150LA / PL150LR	SP150LR
LAK-1316, OF, OH-113	70/86		PL150LA / PL150LR	SP150LR
LAP / LAPK / LPK / LPS-321 / O-3226	58/ 86		PL150LA / PL150LR	SP150LR
LB-1516 / 2216, 1319 / 1524/ 2215	64/ 86		PL150LA / PL150LR	SP150LR
LB-1513 / 2013 / 2213 / 2217	70/86		PL150LA / PL150LR	SP150LR
LB-1515 / 1520	64/ 86		PL150LA / PL150LR	SP150LR
LK, LS-111	64/70		PL150LA / PL150LR	SP150LR
LO-608 D	71/86		PL150LA / PL150LR	SP150LR
LO-812	87/		PL150LA / PL150LR	SP150LR
LPO / O-321 / O-362 / O-362A	58/ 86		PL200LR	SP150LR
LS-1625 / LB-2318	87/		PL150LA / PL150LR	SP150LR
O-326	65/71		PL150LAS / PL150LRS	SP150LR
O-352	69/71		PL150LAS / PL150LRS	SP150LR
O-355	72/78		PL150LAS / PL150LRS	SP150LR
O-362 / O-362 A	71/78		PL170TD	
O-364 / 365 / 370 / 371	79/ 86		PL150LAS / PL150LRS	SP150LR
O-331, O-352, O-355	58/ 86		PL150LA / PL150LR	SP150LR
OH-1313, OH-1316	71/ 86		PL200LR	
OH -1115 / 1314 / 1315 / 1420 / 1318	87/		PL150LA / PL150LR	SP150LR
OH - 1419	82/86		PL150LA / PL150LR	SP150LR
OH-1517	76/86		PL150LA / PL150LR	SP150LR
LPO-1520 / L / LK	64/ 86		PL170TD	
SCANIA				
GAMINHÕES SÉRIE 4	Todos		PLS150TES	
F112HL/ K112/ L112/ S112/ T112/ L142	Todos		PL150LAS / PL150LRS	SP150LR
F113HL/ K113/ R113/ S113/ T113/ R143	Todos		PL150LAS / PL150LRS	
ÔNIBUS SÉRIE 4	Todos		PL175LRS	
ÔNIBUS URBANO	Todos		PL150LAS / PL150LRS	SP150LR
VOLKSWAGEN				
6-80 / 6-90 / 9-140 / 7-90 / S7.110 / 8-120 / 8-150	Todos		PL100ER	
11160	Todos		PL100ERS	
12140H / 14150 / 14200 / 14220 / 24250	Todos		PL170TD / PL170LR	



MARCA/ MODELO		DIESEL		
		PLUS	PESADA	PESADA SPA
VOLKSWAGEN (cont.)				
12660	Todos		PL100ERS	
13-150	Todos		PL100ER	
13-180 / 13-19 / 15-180 / 15-190	Todos		PL150LA / PL150LR	
13-180E (eletrônico)	Todos		PL100ERS	
17.210 / 17.220	Todos		PL150LA / PL150LR	
17240 OP	Todos		PL150LA / PL150LR	
22-140 / 22-160	Todos		PL150LA / PL150LR	
23.210 / 23.220	Todos		PL150LA / PL150LR	
26.220 / 26.260	Todos		PL150LA / PL150LR	
31260	Todos		PL150LA / PL150LR	
E11/ E13/ E21	Todos		PL100ER	
TITAN 18-310	Todos		PL100ERS	
TITAN CONSTELATION 13-180/ 24-250/ 23-250	Todos		PL100ERS	
TITAN CONSTELATION 19-320	Todos		PL150LAS / PL150LRS	
VOLVO				
B10M / B58	79/		PL150LRS	
B10M / B58 ARTICULADOS	79/		PL200LRS	
N104 / 10XH / 10XHT	79/		PL150LRS	
N1016/ N1020 / N1033	79/		PL150LRS	
N12 / 12XH / 12XHT / LINHA NL	79/		PL150LRS	
ÔNIBUS	99/		PLS170TDS	
SÉRIE FH E NH	99/02		PLS170TDS	
SÉRIE FH E NH	03/		PL175LRS	



CARACTERÍSTICAS TÉCNICAS:

TIPO	Características Elétricas +/- 10%				Dimensão Externa (mm)		
	C20 (Ah)	RC (min)	CCA (A)	CA (A)	comp.	larg.	alt.
PL150LR	150	270	950	*	511	213	236
PLS150TE	150	280	950	*	513	223	218
PL170TD	170	330	1000	*	510	213	235
PL170LR	170	330	1000	*	511	213	236
PLS170TD	170	300	1000	*	513	223	218
PL175LR	175	320	1100	*	513	223	218
PL200LR	200	360	1000	*	530	280	246
BATERIAS TIPO SPA							
SP45DR	45		300		210	175	175
SP45ER	45		300		210	175	175
SP60DR	60		375		240	175	175
SP60ER	60		375		240	175	175
SP150LR	150		850		510	213	235

Obs.: * O potencial de corrente do teste é muito alto e não pode ser realizado, pois a destruiria a construção interna da bateria.
** Valores de teste não declarados.
- Não possui equivalência

CUIDADOS ESPECIAIS:

ESTOCAGEM:

As baterias devem ser armazenadas sobre estrados de madeira (pallet), na posição horizontal (nunca inclinada ou deitada), em lugar seco, sem incidência de raios solares e com temperatura entre 10°C e 35°C.

O empilhamento máximo permitido é de:

- Baterias leves (até 90Ah) 5 baterias
- Baterias pesadas (acima de 90Ah) 3 baterias

MOVIMENTAÇÃO DO ESTOQUE

Para a conservação das baterias, siga o procedimento chamado FIFO (First in First out), ou seja, a primeira bateria a entrar no estoque deverá ser também a primeira a sair. Verifique, periodicamente, a condição de carga das baterias em estoque, medindo

ATENÇÃO: PARA UMA MANUTENÇÃO SEGURA É MUITO IMPORTANTE QUE TODAS AS REGRAS DE MANUSEIO DE UMA BATERIA SEJAM CUMPRIDAS.

NORMAS DE SEGURANÇA

- Sempre proteja os olhos e a face, usando óculos de segurança e máscara.
- O ácido sulfúrico é um líquido venenoso e corrosivo, que pode causar queimaduras e irritações na pele e nos olhos, podendo também danificar roupas.
- Nunca fume ao manusear uma bateria. O gás hidrogênio liberado pela bateria, quando em recarga, é explosivo e faíscas podem causar explosão.
- Para evitar curto circuito entre os polos, nunca coloque ferramentas sem isolamento sobre a bateria.
- Só faça recargas na bateria em local bem ventilado.
- Ao realizar um processo de recarga, certifique-se de que o carregador está desligado antes de conectar ou desconectar a bateria.
- Sempre lave bem as mãos após o manuseio de uma bateria.

CASOS DE EMERGÊNCIA

- Em contato com a pele ou olhos, lave o local imediatamente com água em abundância e procure socorro médico imediatamente.
- Em caso de ingestão, beba grande quantidade de água ou leite e em seguida leite de magnésia ou ovos batidos e procure socorro médico imediatamente.
- Em caso de vazamento de ácido, neutralize a área afetada com bicarbonato de sódio.



bateria - máquina agrícola

102

MARCA/ MODELO		DIESEL		
		PLUS	PESADA	PESADA SPA

AGCO - MASSEY FERGUSON

COLHEITADEIRA MF 34/ MF 35	Todos		PL150LA / PL150LR	
COLHEITADEIRA MF 3640 / MF3650	Todos		PL150LA / PL150LR	
COLHEITADEIRA 210/ 220/ 1630	Todos		PL100ER	
RETROESCAVADEIRA 750	/ 90		PL150LA	SP150LR
RETROESCAVADEIRA 751	91/	PL75DRS		
RETROESCAVADEIRA MF 86HS/ MF96	Todos		PL100ER	
TRATOR 250/ 265/ 266/ 270/ 272/ 275/ 283/ 285/ 290/ 292	Todos		PL100ER	
TRATOR 295/ 296/ 297/ 299	78/		PL150LA	SP150LR
TRATOR 4780	83/		PL150LA / PL150LR	SP150LR
TRATOR 50/ 55X/ 65/ 65X/ 85/ 85R/ 85X/ 86/ 95X	Todos		PL100ER	
TRATOR 5275/ 5285/ 5290/ 3000	Todos		PL100ER	
TRATOR 610/ 620	Todos		PL100ER	
TRATOR 630/ 640/ 650/ 660/ 680/ 970	Todos		PL150LA / PL150LR	
TRATOR 6350/ 6360	Todos		PL170TD PL170LR	
TRATOR 6855/ 9090	Todos		PL100ER	
TRATOR 9150/ 9170 (TURBO)	89/		PL100ER	

AGRALE TRATORES

AG 4200/ 4300	Todos		PL100ER	
BX60/ 90/ 100/ 130	90/ 98		PL150LA	SP150LR
BX4.60/ BX4.90/ BX4.110 BX4.130 BX4.150	90/ 00		PL150LA	SP150LR
BX6.110 / 6.150/ 6.180	90/ 98		PL150LA	SP150LR
4100/ 4118/ 4120/ 4230/ 4240/ 4300	77/	PL45DR		

CASE (J. J. CASE)

COLHEITADEIRA AXIAL-FLOW 284CV	Todos		PL100ER	
TRATOR MX MAGNUN 220-270CV	Todos	PL70DRP		
TRATOR MXM MAXXUM 137-177 CV	Todos	PL70DRP		
ESCAVADEIRA CX220	Todos		PL100ERS	
MOTONIVELADORA 845	Todos		PL100ERS	
PÁ CARREGADEIRA COMPACTA 40XT/ 60XT/ 70XT/ 75XT	Todos	PL70DRP		
PÁ CARREGADEIRA 521D/ 621D/ 721D/ 821C/ 921C	Todos		PL100ERS	
PÁ CARREGADEIRA W20/ 20A36	Todos		PL150LAS / PL150LRS	
RETROESCAVADEIRA 580L.3	Todos		PL100ER	
RETROESCAVADEIRA 580H	Todos		PL100ER	

CATERPILLAR

CAMINHÕES FORA DE ESTRADA 769/ 777/ 773E/ 775E	Todos		PL200LR	
CAMINHÕES FORA DE ESTRADA R-22/ 33303	73/		PL200LR	
CAMINHÕES FORA DE ESTRADA R-35	76/		PL200LR	
CAMINHÕES FORA DE ESTRADA R-70	Todos		PL200LR	
CAMINHÕES T/ TT-24T. D'ÁGUA	79/		PL200LR	
CARREGADEIRAS DE RODAS 920/ 955/ 973/ 977/ 980/ 988	Todos		PL200LR	
MOTO SCRAPERS F-24/ TS-24	Todos		PL200LR	
MOTO SCRAPERS TS-14R	73/		PL150LA	
MOTONIVELADORAS 14/ 16/ 112	Todos		PL200LR	
TRATOR D9N/ D7/ DL8/ D8	Todos		PL200LR	
TRATORES DE ESTEIRA PEQUENO E MÉDIO D3/ D4/ D5/ D6C/ 966C	Todos		PL150LA	

CLARK TRATORES

C300-HY40/ 50/ 60/ C500-HY70/ 80	Todos		PL100ER	
C500/ Y100/ Y135/ 155	81/		PL200LR	
CARREGADEIRAS 45C/ 55-A2 E 2.1/ 2JC	Todos		PL150LA / PL150LR	
CARREGADEIRAS 125 ART/ 125 X/ 75-III/ 75HD	70/		PL150LA	SP150LR
GUINDASTE AM720	78/		PL200LR	

ENGESA

EE 1124/ 1128/ 1428	80/		PL200LR	
EE 815/ 510	75/		PL150LA	SP150LR



Linha de produtos Magneti Marelli
Bateria para Empilhadeiras,
Máquinas Agrícolas
e Terraplanagem



MARCA/ MODELO		DIESEL		
		PLUS	PESADA	PESADA SPA
FIAT ALLIS				
AD 148/ AD 14C/ AD20/ FL4C/ FL8C/ 14B, S-9	Todos		PL150LA / PL150LR	
AD7B/ 7BTA/ 14CSTA/ 14CS	Todos		PL150LA / PL150LR	
HUBER WABCO/ DRESSER				
GUINDASTE 150A	73/		PL200LR	
JOHN DEERE				
COLHEITADEIRA 1165/ 1175	Todas		PL150LA / PL150LR	
COLHEITADEIRA 1450	Todas		PL150LA / PL150LR	
COLHEITADEIRA 1550	Todas		PL150LA / PL150LR	
COLHEITADEIRA 1650	Todas		PL150LA / PL150LR	
COLHEITADEIRA 9650/ 9660	Todas		PL150LA / PL150LR	
COLHEITADEIRA 9750	Todas		PL150LA / PL150LR	
COLHEITADEIRA DE CANA CH2500B	Todas		PL100ER	
FORRAGEIRAS	Todas		PL150LA / PL150LR	
PULVERIZADOR 4720	Todos		PL100ER	
TRATOR 5403/ 5605 (75 CV)	Todos		PL100ER	
TRATOR 5705 (85 CV)	Todos		PL100ER	
TRATOR 6415 (106 CV)	Todos		PL100ER	
TRATOR 6615 (121 CV)	Todos		PL150LA / PL150LR	
TRATOR 7515 (140 CV)	Todos		PL150LA / PL150LR	
TRATOR 7815 (200 CV)	Todos		PL150LA / PL150LR	
TRATOR 8420 (270 CV)	Todos		PL150LA / PL150LR	
KOMATSU				
TRATOR D50A/ D30E	Todos		PL150LA / PL150LR	
TRATOR D60/ D65A	Todos		PL200LR	
MALVES				
MD850/ 920 - P/ 2100	Todos		PL150LA / PL150LR	
MÜLLER				
AP20/ AP23/ AP26/ AP35	69/		PL150LA	SP150LR
ESCAVADEIRA C/ MOTOR M. BENZ	74/		PL150LA	SP150LR
TC-15B TRAT. COMPACT	73/		PL150LA	SP150LR
TC20	73/		PL100ER	
TI-18/ 25/ TC18/ 23/ 28	73/		PL150LA	SP150LR
TM 12/ 14/ 17/ 25/ 31	73/		PL150LA	SP150LR
VAP-70 VIBR. AUTOPROPUL.	74/		PL150LA	SP150LR
NEW HOLLAND				
4830 / 5030 / 6630 / 7830	/ 93		PL100ER	
8430 / 8030	Todos		PL150LA / PL150LR	
8630 / 8830	Todos		PL170TD / PL170LR	
MOTONIVELADORA RG140.B/ RG170B/ RG200.B	Todos		PL100ERS	
PÁ CARREGADEIRA 12B/ W130TC/ W160/ W200	Todos		PL100ERS	
RETROESCAVADEIRA LB90/ LB110	Todos		PL100ER	
TL C/ CABINE	Todos	PL60DRP		
TL S/ CABINE/ 7630	Todos		PL100ER	
TRATOR COLHEITADEIRA CS660	Todos	PL90DRP		
TRATOR COLHEITADEIRA TC/ PLATAFORMA DE GRÃOS	Todos		PL170TD / PL170LR	
TRATOR COLHEITADEIRA TM137 á 177 CV	Todos	PR70DRP		
TRATOR COLHEITADEIRA TL 62 á 98 CV	Todos		PL100ER	
TRATOR COLHEITADEIRA TS 104,4 á 119,6 CV	Todos		PL150LA / PL150LR	
TRATOR COLHEITADEIRA SÉRIE 30 S100 104,4 á 120,9 CV	Todos		PL100ER	
TRATOR DE ESTEIRA 7D/ D130/ D170	Todos		PL100ERS	



Linha de produtos Magneti Marelli
Bateria para Empilhadeiras,
Máquinas Agrícolas
e Terraplanagem



bateria - máquina agrícola

104

MARCA/ MODELO		DIESEL		
		PLUS	PESADA	PESADA SPA
POCLAIN				
2T/ 4/ T/ 67	78/		PL150LA	SP150LR
RANDON				
RK 628 C/ 425 B/ 430 B/ 435 N	Todos		PL150LA / PL150LR	
SVEDALA DYNAPAC				
COMPACT, VIBRATÓRIO MODO CA 25-M	Todos		PL150LA	
TEMA TERRA				
597-C/ 5299/ 5300/ 5530/ 5720	75/		PL150LA	SP150LR
84B PULV. - MIST. SOLO	71/ 76		PL150LA	SP150LR
SP-225	69/		PL200LR	
SP-5550	74/		PL100ER	
SP-8000/ SP-120000	Todos		PL150LA	
SPV-735/ 755-VA/ VP-15D/ VP-15DP	71/		PL100ER	
SSPRM-7	77/		PL150LA	SP150LR
TH-10/ TH-14/ TT-1014	Todos		PL100ER	
TT-4420	76/		PL150LA	SP150LR
TEREX				
MOTO NIVELADORA 619 SÉRIE C 922/ 933/ 944/ 955/ 966/ 977	60/ 63	PL75ERP		
PÁ CARREGADEIRA 72-51/ 72-52	74/		PL200LR	
SCRAPERS 621B, 62-7B/ PP631D, 637-D/ PP769B/ C	Todos		PL200LR	
SCRAPERS TS-14	78/		PL200LR	
SCRAPERS TS-24A/ F-24A	78/		PL200LR	
VALMET/ VALTRA				
TRATOR DE RODA BH140/ BH160/ BH180	Todos		PL100ER	
TRATOR DE RODA 1580/ 1780	Todos		PL100ER	
TRATOR DE RODA BM100/ BM110/ BM120	Todos		PL100ER	
TRATOR DE RODA BL88	Todos		PL100ER	
TRATOR SÉRIE 100 = 700/ 800/ 900	Todos		PL100ER	
TRATOR DE RODA LINHA LEVE 685C/ 785C	Todos		PL100ER	
TRATOR BF65/ BF75	Todos		PL100ER	
TRATOR 780 / 880 / 128 / 148	85/		PL100ER	
TRATOR 88/ 88PCR	81/		PL100ER	
TRATOR 885	89/		PL100ER	
TRATOR 985	90/		PL100ER	
TRATORES 118-A/ 118-4A/ 88A/ 88S	83/ 86		PL100ER	
TRATORES 980/ 1118/ 1280/ 1580/ 1780	85/		PL100ER	
VOLVO CONSTRUCTION EQUIPAMENT				
CAMINHÕES FORA DE ESTRADA A25D/ A30D/ A35D/ A40D	Todos		PL170TDS	ANO
WABCO				
CAMINHÕES FORA DE ESTRADA	Todos		PL200LR	
YALE				
EMPILHADEIRA C/ MOTOR WV 1300	80/	PL45DR		
TRATORES E MOTORES ESTACIONÁRIOS	Todos		PL200LR	
ZECTOR				

CROSS REFERENCE

HELIAR	AC DELCO	MAGNETI MARELLI	MOURA	TUDOR	CRAL	AJAX
RT100LE	22A100E2	PL100ER	MI100HE MI100HS	TF105MPD	CS100 E	AJ 100 MA
RT150TD	22A150D3	PL150LA	MP150BD	T150MVD	CS150D	AJ 150 MB AJ 160 MB
RTP150TD	33B150D3	PL150LR	-	TF150MVD	CP160HD	LS/LM 150 MB
SRT150TE	22T150E3	PLS150TE	-	T150MSE	-	AJ 150 SC
RT170TD	22A170D3	PL170TD	MP170BE	TF170MVD	CP180HD	AJ 175 MB / VO
RTP170TD	33B170D3	PL170LR	-	-	CP160HD	-
SRT170TD		PLS170TD	-	-	CO170VD	-
SRT175TE	22T175E3	PL175LR	-	T170MSE	CO170VE	-
RT200TD	22A200D3	PL200LR	MI200PD	T200MBD	CP205HD	AJ 200 ON

PROCEDIMENTO DE RECARGA:

O tempo de recarga varia de acordo com o estado de carga da bateria e a capacidade do equipamento de recarga. Para se fazer o controle do estado de carga deve-se utilizar um voltímetro com pelo menos duas casas decimais.

TABELA DE RECARGA: Tensão Constante 16V - Corrente Limitada a 25 A

Tensão da Bateria em Vazio (V)	Tempo de Recarga (Horas)
12,00 a 12,20	6 a 12
11,80 a 11,99	10 a 16
11,50 a 11,79	16 a 20
11,00 a 11,49	20 a 24
Baterias profundamente descarregadas	24 a 30

A temperatura da bateria não deve ultrapassar 50°C durante o processo de recarga.

TABELA DE RECARGA: Corrente Constante (10% Cap. Nominal)

Tensão da Bateria em Vazio (Volts)	Tempo de Recarga (Horas)
12,00 a 12,20	4.5
11,80 a 11,99	7.0
11,50 a 11,79	9.0
11,00 a 11,49	11.0
Baterias descarregadas (total)	15.0

A temperatura da bateria não deve ultrapassar 50°C durante o processo de recarga

Consumo Máximo por Equipamento:

Computador de Bordo	05 mA
Alarme	10 mA
Central de Levanta Vidros	05 mA
Central de Ignição	05 mA
Central de Injeção	05 mA
Relógio Digital	03 mA
Rádio com Sistema e Código	03 mA
Relógio Analógico	07 mA

Máxima corrente de fuga permitida:

Para baterias de até 45Ah = 20mA
Para baterias entre 50Ah e 75Ah = 40mA
Para baterias entre 90Ah e 100Ah = 70mA

INDICAÇÃO DO ESTADO DE CARGA - CHARGE EYE

Visor c/ cor Verde: Bateria com carga normal, acima de 65%

Visor c/ cor Preta: Bateria com carga abaixo de 65%, verificar sistema elétrico do veículo e estado de carga da bateria. A cor preta não significa que a bateria apresenta defeito.

Visor c/ cor Branca: Bateria sem condição de uso devido a possível sobrecarga. Verificar sistema elétrico do veículo. Baterias nesta condição não são cobertas pela garantia.

linha de
produtos

MAGNET
MARE

bomba d'água



CÓDIGO MAGNETI MARELLI	APLICAÇÃO	MOTOR		Obs.:	URBA	INDISA	CÓDIGO ORIGINAL
AGCO							
BMM0581	4400 Trator	3 Cil Diesel	01/76 a 12/86	Com Tampa Traseira	UB0581	7000200000	D8NN85601NA
BMM0582	4400 Trator	3 Cil Diesel	01/76 a 12/86	Sem Tampa Traseira	UB0582	7000201000	D8NN8501NA
BMM0581	4500 Trator	3 Cil Diesel	01/76 a 12/86	Com Tampa Traseira	UB0581	7000200000	D8NN85601NA
BMM0582	4500 Trator	3 Cil Diesel	01/76 a 12/86	Sem Tampa Traseira	UB0582	7000201000	D8NN8501NA
BMM0581	4600 Trator	3 Cil Diesel	01/76 a 12/86	Com Tampa Traseira	UB0581	7000200000	D8NN85601NA
BMM0582	4600 Trator	3 Cil Diesel	01/76 a 12/86	Sem Tampa Traseira	UB0582	7000201000	D8NN8501NA
BMM0581	4610 Trator	3 Cil Diesel	01/76 a 12/86	Com Tampa Traseira	UB0581	7000200000	D8NN85601NA
BMM0582	4610 Trator	3 Cil Diesel	01/76 a 12/86	Sem Tampa Traseira	UB0582	7000201000	D8NN8501NA
BMM0581	5000 Trator	Diesel	01/81 a 12/91	Com Tampa Traseira	UB0581	7000200000	D8NN85601NA
BMM0582	5000 Trator	Diesel	01/81 a 12/91	Sem Tampa Traseira	UB0582	7000201000	D8NN8501NA
BMM0581	5600 Trator	Diesel	01/81 a 12/91	Com Tampa Traseira	UB0581	7000200000	D8NN85601NA
BMM0582	5600 Trator	Diesel	01/81 a 12/91	Sem Tampa Traseira	UB0582	7000201000	D8NN8501NA
BMM0581	5610 Trator	Diesel	01/81 a 12/91	Com Tampa Traseira	UB0581	7000200000	D8NN85601NA
BMM0582	5610 Trator	Diesel	01/81 a 12/91	Sem Tampa Traseira	UB0582	7000201000	D8NN8501NA
BMM0581	6600 Trator	Diesel	01/81 a 12/91	Com Tampa Traseira	UB0581	7000200000	D8NN85601NA
BMM0582	6600 Trator	Diesel	01/81 a 12/91	Sem Tampa Traseira	UB0582	7000201000	D8NN8501NA
BMM0581	6610 Trator	Diesel	01/81 a 12/91	Com Tampa Traseira	UB0581	7000200000	D8NN85601NA
BMM0582	6610 Trator	Diesel	01/81 a 12/91	Sem Tampa Traseira	UB0582	7000201000	D8NN8501NA
BMM0576	AD7B Trator	MWM D225 6 Cil Diesel	01/80 a 12/90		UB0576	7000104000	
BMM0576	AD7BTA Trator Diesel	MWM D225 6 Cil Diesel	01/80 a 12/90		UB0576	7000104000	
BMM0576	FA120 Trator	MWM TD229 EC 6 Cil Diesel	01/80 a 12/90		UB0576	7000104000	
BMM0576	FB80 Trator	MWM D225 4 Cil Diesel	01/80 a 12/90		UB0576	7000104000	
BMM0576	FD9 Trator	MWM TD229 EC 6 Cil Diesel	01/80 a 12/90		UB0576	7000104000	
BMM0576	FD9B Trator	MWM TD229 EC 6 Cil Diesel	01/80 a 12/90		UB0576	7000104000	
BMM0313	FG70 Trator	OM 352 6 Cil Diesel	01/80 a 12/90	Com Tampa, Rotor com diam. 88 mm	UB0313	7000400000	3522003801, 3522003811, 3522009401
BMM0314	FG70 Trator	OM 352 6 Cil Diesel	01/80 a 12/90	Sem Tampa	UB0314	7000401001	3522003801, 3522003801X, 3522009401, 3522009401X
BMM0315	FG70 Trator	OM 352A 6 Cil Diesel	01/80 a 12/90	Com Tampa, Rotor Diam. 95 mm	UB0315	7000400001	3532000301
BMM0316	FG70 Trator	OM 352A 6 Cil Diesel	01/80 a 12/90	Sem Tampa, Rotor Diam. 95 mm	UB0316	7000401002	3532000301X
BMM0313	FG75 Trator	OM 352 6 Cil Diesel	01/80 a 12/90	Com Tampa, Rotor com diam. 88mm	UB0313	7000400000	3522003801, 3522003811, 3522009401
BMM0314	FG75 Trator	OM 352 6 Cil Diesel	01/80 a 12/90	Sem Tampa	UB0314	7000401001	3522003801, 3522003801X, 3522009401, 3522009401X



Linha de produtos Magneti Marelli Bomba d'água



CÓDIGO MAGNETI MARELLI	APLICAÇÃO	MOTOR		Obs.:	URBA	INDISA	CÓDIGO ORIGINAL
------------------------	-----------	-------	---	-------	------	--------	-----------------

AGCO (cont.)

BMM0315	FG75 Trator	OM 352A 6 Cil Diesel	01/80 a 12/90	Com Tampa, Rotor Diam. 95 mm	UB0315	7000400001	3532000301
BMM0316	FG75 Trator	OM 352A 6 Cil Diesel	01/80 a 12/90	Sem Tampa, Rotor Diam. 95 mm	UB0316	7000401002	3532000301X
BMM0578	FH200 Trator	MWM TD229 EC 6 Cil Diesel	01/80 a 12/90		UB0578	7000104001	
BMM0578	FR10B Trator	MWM TD229 EC 6 Cil Diesel	01/80 a 12/90		UB0578	7000104001	
BMM0578	FR12B Trator	MWM TD229 EC 6 Cil Diesel	01/80 a 12/90		UB0578	7000104001	
BMM0578	FR14B Trator	MWM TD229 EC 6 Cil Diesel	01/80 a 12/90		UB0578	7000104001	

AGRALE

BMM0576	1800	MWM D229 4 Cil Diesel	01/83 a 12/93		UB0576	7000104000	92200507310015, 922987310026
BMM5003	6000	MWM 2.8 Turbo Diesel - 4 Cil			-	7000105003	940707310055
BMM0576	7000	MWM D229 4 Cil Diesel	01/83 a 12/02		UB0576	7000104000	92200507310015, 922987310026
BMM0578	7500	MWM TD229 EC 4 Cil Diesel	01/80 a 12/90		UB0578	7000104001	922907310015, 922987310036
BMM0576	BX 100	MWM TD229 EC 4 Cil Diesel	01/80 a 12/90		UB0576	7000104000	92200507310015, 922987310026
BMM0576	BX 130	MWM D229 6 Cil Diesel	01/80 a 12/90		UB0576	7000104000	92200507310015, 922987310026
BMM0576	BX 4.130	MWM D229 6 Cil Diesel	01/80 a 12/90		UB0576	7000104000	92200507310015, 922987310026
BMM0578	BX 4.150	MWM TD229 EC 6 Cil Diesel	01/80 a 12/90		UB0578	7000104001	922907310015, 922987310036
BMM0576	BX 410	MWM TD229 EC 4 Cil Diesel	01/80 a 12/90		UB0576	7000104000	92200507310015, 922987310026
BMM0576	BX 490	MWM D229 4 Cil Diesel	01/80 a 12/90		UB0576	7000104000	92200507310015, 922987310026
BMM0576	BX 90	MWM D229 4 Cil Diesel	01/80 a 12/90		UB0576	7000104000	92200507310015, 922987310026
BMM0576	TX 1600	MWM D229 3 Cil Diesel	01/80 a 12/90		UB0576	7000104000	92200507310015, 922987310026

CASE

BMM0982	2470	Scania DS11 6 Cil Diesel	01/78 a 12/88		UB0982	7000553000	259065
BMM0982	4440	Scania DS11 6 Cil Diesel	01/80 a 12/90		UB0982	7000553000	259065
BMM0325	580H	Perkins 4236 4 Cil Diesel	01/80 a 12/90	Com Polia	UB0325	7000153003	70992287
BMM0325	580H	Perkins 4248 4 Cil Diesel	01/80 a 12/90	Com Polia	UB0325	7000153003	70992287
BMM0326	580H	Perkins 4236 4 Cil Diesel	01/80 a 12/90	Sem Polia	UB0326	7000152000	70991175X, 70992287X
BMM0326	580H	Perkins 4248 4 Cil Diesel	01/80 a 12/90	Sem Polia	UB0326	7000152000	70991175X, 70992287X
BMM0576	Escavadeira	MWM D225 4 Cil Diesel	01/80 a 12/90		UB0576	7000104000	
BMM0576	Escavadeira	MWM D225 6 Cil Diesel	01/80 a 12/90		UB0576	7000104000	
BMM0576	Escavadeira	MWM D229 6 Cil Diesel	01/80 a 12/90		UB0576	7000104000	

CBT

BMM0329	Trator 1000	Perkins 4203 4 Cil Diesel	01/66 a 12/76	Com Polia	UB0329	7000153001	70991412
BMM0330	Trator 1000	Perkins 4203 4 Cil Diesel	01/66 a 12/76	Sem Polia	UB0330	7000152001	70990329X
BMM0608	Trator 1065	MB OM 314 4 Cil Diesel	01/72 a 12/82		UB0608	7000401000	3142000601 e 3142002901
BMM0553	Trator 1090A	Perkins 6357 6 Cil Diesel	01/69 a 12/81	Com polia simples 5 1/2"	UB0553	7000153005	70990563, 70991409, P70991409A



CÓDIGO MAGNETI MARELLI	APLICAÇÃO	MOTOR		Obs.:	URBA	INDISA	CÓDIGO ORIGINAL
------------------------	-----------	-------	---	-------	------	--------	-----------------

CBT (cont.)

BMM0554	Trator 1090A	Perkins 6357 6 Cil Diesel	01/69 a 12/81	Sem Polia	UB0554	7000152004	70990553X, 70990563X, 70991409X, 7099168X, P70991409AX
BMM0313	Trator 1105	OM 352 6 Cil Diesel	01/73 a 12/83	Com Tampa,	UB0313	7000400000	3522003801, 3522003811, 3522009401
BMM0314	Trator 1105	OM 352 6 Cil Diesel	01/73 A 12/83	Sem Tampa	UB0314	7000401001	3522003801, 3522003801X, 3522009401, 3522009401X
BMM0562	Trator 2500	PERKINS QB20B - 6354 4/6 cil	Todos	Sem polia.	UB0562	7000152006	41313027, 6354141
BMM0562	Trator 8260 (4x4)	PERKINS QB20B - 6354 4/6 cil	Todos	Sem polia.	UB0562	7000152006	41313027, 6354141
BMM0576	Trator 8440	MWM D229 4 Cil Diesel	01/80 A 12/90		UB0576	7000104000	
BMM0578	Trator 8450	MWM TD229 EC 4 Cil Diesel	01/80 A 12/90		UB0578	7000104001	

CHEVROLET

BMM0334	6000	4.1 Maxion S4T Diesel	01/92 a 12/96		UB0334	7000153010	000S4054, 000S4056, 70992563
BMM0334	6000	4.1 Maxion S4T Plus Diesel	01/92 a 12/96		UB0334	7000153010	000S4054, 000S4056, 70992563
BMM0577	6150	MWM Sprint 4 Cil Diesel	01/85 a 12/06	Engrenagem 15°	UB0577	7000105002	940707310035
BMM0560	11000	Perkins Q20B 6 Cil Diesel	01/85 a 01/95	Sem polia	UB0560	7000253000	41313033, 41313047, 70992422
BMM0560	11000	Perkins 6354 6 Cil Diesel	01/85 a 01/95	Sem polia	UB0560	7000253000	41313033, 41313047, 70992422
BMM2004	11000	PERKINS QB20B 6 Cil	01/85 a ...		-	7000252004	70992422, 41313047, 41313033
BMM2004	12000	PERKINS QB20B 6 Cil	01/85 a ...		-	7000252004	70992422, 41313047, 41313033
BMM2004	13000	PERKINS QB20B 6 Cil	01/85 a ...		-	7000252004	70992422, 41313047, 41313033
BMM2004	14000	PERKINS QB20B 6 Cil	01/85 a ...		-	7000252004	70992422, 41313047, 41313033
BMM0732	16220	Cummins 6CT 8.3 Diesel	01/80 a 12/90		UB0732	7000452000	3802081, 3913430
BMM2004	21000	PERKINS QB20B 6 Cil	01/85 a ...		-	7000252004	70992422, 41313047, 41313033
BMM0560	22000	Perkins Q20B 6 Cil Diesel	01/85 a 01/95	Sem polia	UB0560	7000253000	41313033, 41313047, 70992422
BMM0560	22000	Perkins 6354 6 Cil Diesel	01/85 a 01/95	Sem polia	UB0560	7000253000	41313033, 41313047, 70992422
BMM2004	22000	PERKINS QB20B 6 Cil	01/85 a ...		-	7000252004	70992422, 41313047, 41313033
BMM0331	A/C/D 40	Perkins QB20B 4 Cil Diesel	01/84 a 12/92	Com Polia	UB0331	7000153006	70991456, 70992164, 70992165
BMM0332	A/C/D 40	Perkins QB20B 4 Cil Diesel	01/84 a 12/92	Sem Polia	UB0332	7000152002	70991456X, 70992164X, 70992165X, 70992165
BMM0553	A/C/D 60	Perkins 6357 6 Cil Diesel	01/69 a 12/80	Com polia simples 5 1/2"	UB0553	7000153005	70990563, 70991409, P70991409A
BMM0554	A/C/D 60	Perkins 6357 6 Cil Diesel	01/69 a 12/80	Sem Polia	UB0554	7000152004	70990553X, 70990563X, 70991409X, 7099168X, P70991409AX
BMM0558	A/C/D 60	Perkins 6358 6 Cil Diesel	01/81 a 12/84	Sem polia	UB0558	7000152005	70991410, 70991452, 90991410
BMM0560	A/C/D 60	Perkins Q20B 6 Cil Diesel	01/85 a 01/95	Sem polia	UB0560	7000253000	41313033, 41313047, 70992422



Linha de produtos Magneti Marelli Bomba d'água



CÓDIGO MAGNETI MARELLI	APLICAÇÃO	MOTOR		Obs.:	URBA	INDISA	CÓDIGO ORIGINAL
CHEVROLET (cont.)							
BMM0560	A/C/D 60	Perkins 6354 6 Cil Diesel	01/85 a 01/95	Sem polia	UB0560	7000253000	41313033, 41313047, 70992422
BMM0554	A/C/D 70	Perkins 6357 6 Cil Diesel	01/69 a 12/80	Sem Polia	UB0554	7000152004	70990553X, 70990563X, 70991409X, 7099168X, P70991409AX
BMM0558	A/C/D 70	Perkins 6358 6 Cil Diesel	01/81 a 12/84	Sem polia	UB0558	7000152005	70991410, 70991452, 90991410
BMM0560	A/C/D 70	Perkins Q20B 6 Cil Diesel	01/85 a 01/95	Sem polia	UB0560	7000253000	41313033, 41313047, 70992422
BMM0560	A/C/D 70	Perkins 6354 6 Cil Diesel	01/85 a 01/95	Sem polia	UB0560	7000253000	41313033, 41313047, 70992422
BMM0558	A/C/D 80	Perkins 6358 6 Cil Diesel	01/81 a 12/84	Sem polia	UB0558	7000152005	70991410, 70991452, 90991410
BMM0560	A/C/D 80	Perkins Q20B 6 Cil Diesel	01/85 a 01/95	Sem polia	UB0560	7000253000	41313033, 41313047, 70992422
BMM0560	A/C/D 80	Perkins 6354 6 Cil Diesel	01/85 a 01/95	Sem polia	UB0560	7000253000	41313033, 41313047, 70992422
BMM0560	A/C/D 90	Perkins Q20B 6 Cil Diesel	01/85 a 01/95	Sem polia	UB0560	7000253000	41313033, 41313047, 70992422
BMM0560	A/C/D 90	Perkins 6354 6 Cil Diesel	01/85 a 01/95	Sem polia	UB0560	7000253000	41313033, 41313047, 70992422
BMM0334	D40	4.1 Maxion S4T Diesel	01/92 a 12/96	Polia dupla	UB0334	7000153010	000S4054, 000S4056, 70992563
BMM0334	D40	4.1 Maxion S4T Plus Diesel	01/92 a 12/96	Polia dupla	UB0334	7000153010	000S4054, 000S4056, 70992563
BMM2004	D60	PERKINS QB20B 6 Cil	01/69 a 12/80		-	7000252004	70992422, 41313047, 41313033
BMM2004	D70	PERKINS QB20B 6 Cil	01/69 a 12/80		-	7000252004	70992422, 41313047, 41313033
BMM2004	D80	PERKINS QB20B 6 Cil	01/69 a 12/80		-	7000252004	70992422, 41313047, 41313033

CLARK

BMM0135	CFY-20	GM 151 4 Cil Diesel	01/63 a 12/71		UB0135	7000254000	7330495, 7322682
BMM0135	CFY-25	GM 151 4 Cil Diesel	01/63 A 12/71		UB0135	7000254000	7330495, 7322682
BMM0054	CFY-40	Ford BF 161 6 Cil Diesel	01/60 A 12/72		UB0054	7000204002	643564 e BD4B8501A
BMM0054	CFY-50	Ford BF 161 6 Cil Diesel	01/60 a 12/72		UB0054	7000204002	643564 e BD4B8501A
BMM0135	CFY-60	GM 250 6 Cil Diesel	01/69 a 12/83		UB0135	7000254000	7330495, 7322682
BMM0135	CHY-100	GM 250 6 Cil Diesel	01/69 a 12/83		UB0135	7000254000	7330495, 7322682
BMM0135	CHY-120	GM 250 6 Cil Diesel	01/69 a 12/83		UB0135	7000254000	7330495, 7322682
BMM0135	CHY-70	GM 250 6 Cil Diesel	01/69 a 12/83		UB0135	7000254000	7330495, 7322682
BMM0135	CHY-80	GM 250 6 Cil Diesel	01/69 a 12/83		UB0135	7000254000	7330495, 7322682

DYNAPAC

BMM2008	Trator C 300	Perkins D-3152 - 3 Cil	Todos	Sem polia	-	7000152008	70991414, 70990318
BMM2008	Trator C 40	Perkins D-3152 - 3 Cil	Todos	Sem polia	-	7000152008	70991414, 70990318
BMM2008	Trator C 50	Perkins D-3152 - 3 Cil	Todos	Sem polia	-	7000152008	70991414, 70990318
BMM2008	Trator C 60	Perkins D-3152 - 3 Cil	Todos	Sem polia	-	7000152008	70991414, 70990318
BMM0560	Rolo Compactador	Perkins Q20B 6 Cil Diesel	01/80 a 12/90	Sem polia	UB0560	7000253000	41313033, 41313047, 70992422
BMM0576	Rolo compactador	MWM D226 4 Cil Diesel	01/80 a 12/90		UB0576	7000104000	
BMM0576	Rolo compactador	MWM D229 4 Cil Diesel	01/80 a 12/90		UB0576	7000104000	
BMM0576	Rolo compactador	MWM D229 6 Cil Diesel	01/80 a 12/90		UB0576	7000104000	
BMM0576	Rolo compactador	MWM TD229 6 Cil Diesel	01/80 a 12/90		UB0576	7000104000	
BMM0562	Rolo compactador CP-27	PERKINS QB20B - 6354 4/6 cil	Todos	Sem polia.	UB0562	7000152006	41313027, 6354141



CÓDIGO MAGNETI MARELLI	APLICAÇÃO	MOTOR		Obs.:	URBA	INDISA	CÓDIGO ORIGINAL
------------------------	-----------	-------	---	-------	------	--------	-----------------

FIAT ALLIS

BMM0576	Trator de Esteiras	MWM TD229 6 Cil Diesel	01/80 a 12/90		UB0576	7000104000	
BMM0313	Trator Rodoviário	OM 352 6 Cil Diesel	01/80 a 12/90	Com Tampa, Rotor com diam. 88mm	UB0313	7000400000	3522003801, 3522003811, 3522009401
BMM0314	Trator Rodoviário	OM 352 6 Cil Diesel	01/80 a 12/90	Sem Tampa	UB0314	7000401001	3522003801, 3522003801X, 3522009401, 3522009401X
BMM0315	Trator Rodoviário	OM 352A 6 Cil Diesel	01/80 a 12/90	Com Tampa, Rotor Diam. 95 mm	UB0315	7000400001	3532000301
BMM0316	Trator Rodoviário	OM 352A 6 Cil Diesel	01/80 a 12/90	Sem Tampa, Rotor Diam. 95 mm	UB0316	7000401002	3532000301X

FORD

BMM0590	1215 Cargo	6.6 Diesel	01/76 a 12/96	Sem Tampa Traseira	UB0590	7000201003	E7HN8A513AB
BMM0731	1215 Cargo	Cummins 6BT-5.9 6 Cil Diesel	01/76 a 11/86		UB0731	7000452002	3802358, 3802970, BF5X/8501/A
BMM0731	1215 Cargo	Cummins 6BTA-5.9 6 Cil Diesel	01/76 a 11/86		UB0731	7000452002	3802358, 3802970, BF5X/8501/A
BMM0731	1215 Cargo	Cummins 6BTAA-5.9 6 Cil Diesel	01/76 a 11/86		UB0731	7000452002	3802358, 3802970, BF5X/8501/A
BMM0731	1217 Cargo	Cummins 6BT-5.9 6 Cil Diesel	01/76 a 11/86		UB0731	7000452002	3802358, 3802970, BF5X/8501/A
BMM0731	1217 Cargo	Cummins 6BTA-5.9 6 Cil Diesel	01/76 a 11/86		UB0731	7000452002	3802358, 3802970, BF5X/8501/A
BMM0731	1217 Cargo	Cummins 6BTAA-5.9 6 Cil Diesel	01/76 a 11/86		UB0731	7000452002	3802358, 3802970, BF5X/8501/A
BMM0590	1415 Cargo	6.6 Diesel	01/76 a 12/96	Sem Tampa Traseira	UB0590	7000201003	E7HN8A513AB
BMM0731	1415 Cargo	Cummins 6BT-5.9 6 Cil Diesel	01/76 a 11/86		UB0731	7000452002	3802358, 3802970, BF5X/8501/A
BMM0731	1415 Cargo	Cummins 6BTA-5.9 6 Cil Diesel	01/76 a 11/86		UB0731	7000452002	3802358, 3802970, BF5X/8501/A
BMM0731	1415 Cargo	Cummins 6BTAA-5.9 6 Cil Diesel	01/76 a 11/86		UB0731	7000452002	3802358, 3802970, BF5X/8501/A
BMM0731	1417 Cargo	Cummins 6BT-5.9 6 Cil Diesel	01/76 a 11/86		UB0731	7000452002	3802358, 3802970, BF5X/8501/A
BMM0731	1417 Cargo	Cummins 6BTA-5.9 6 Cil Diesel	01/76 a 11/86		UB0731	7000452002	3802358, 3802970, BF5X/8501/A
BMM0731	1417 Cargo	Cummins 6BTAA-5.9 6 Cil Diesel	01/76 a 11/86		UB0731	7000452002	3802358, 3802970, BF5X/8501/A
BMM0590	1418 Cargo	6.6 Diesel	01/76 a 12/96	Sem Tampa Traseira	UB0590	7000201003	E7HN8A513AB
BMM0732	1422 Cargo	Cummins 6CT 8.3 Diesel	01/80 a 12/90		UB0732	7000452000	3802081, 3913430
BMM0590	1615 Cargo	6.6 Diesel	01/76 a 12/96	Sem Tampa Traseira	UB0590	7000201003	E7HN8A513AB
BMM0731	1617 Cargo	Cummins 6BT-5.9 6 Cil Diesel	01/76 a 11/86		UB0731	7000452002	3802358, 3802970, BF5X/8501/A
BMM0731	1617 Cargo	Cummins 6BTA-5.9 6 Cil Diesel	01/76 a 11/86		UB0731	7000452002	3802358, 3802970, BF5X/8501/A
BMM0731	1617 Cargo	Cummins 6BTAA-5.9 6 Cil Diesel	01/76 a 11/86		UB0731	7000452002	3802358, 3802970, BF5X/8501/A
BMM0590	1618 Cargo	6.6 Diesel	01/76 a 12/96	Sem Tampa Traseira	UB0590	7000201003	E7HN8A513AB
BMM0732	1622 Cargo	Cummins 6CT 8.3 Diesel	01/80 a 12/90		UB0732	7000452000	3802081, 3913430
BMM0732	2322 Cargo	Cummins 6CT 8.3 Diesel	01/80 a 12/90		UB0732	7000452000	3802081, 3913430
BMM0732	2422 Cargo	Cummins 6CT 8.3 Diesel	01/80 a 12/90		UB0732	7000452000	3802081, 3913430
BMM0732	3224 Cargo	Cummins 6CTAA 8.3 Diesel	01/80 a 12/90		UB0732	7000452000	3802081, 3913430
BMM0732	3530 Cargo	Cummins 6CTAA 8.3 Diesel	01/80 a 12/90		UB0732	7000452000	3802081, 3913430



Linha de produtos Magneti Marelli
Bomba d'água



CÓDIGO MAGNETI MARELLI	APLICAÇÃO	MOTOR		Obs.:	URBA	INDISA	CÓDIGO ORIGINAL
FORD (cont.)							
BMM0584	4000 Cargo	4.4 Diesel	01/82 a 12/92	Sem Tampa Traseira	UB0584	7000201001	E1TN8501AB e E5TN8501AA e E6NN8501KB
BMM0576	Cargo	MWM D229 6 Cil Diesel	01/80 a 12/90		UB0576	7000104000	922507310015, 922987310026, WD5T8501A
BMM0588	Cargo	6.6 Diesel	01/76 a 12/86	Sem Tampa Traseira	UB0588	7000201002	E3HN8501AC e E3HN8501AC1
BMM0590	Cargo	6.6 Diesel	01/76 a 12/96	Sem Tampa Traseira	UB0590	7000201003	E7HN8A513AB
BMM1007	Cargo	Fase III FTO 7.8			-	7000201007	E9HN8A513CB
BMM0596	Colheitadeira TC 55	6 Cil	01/93	C/ polia dupla.	UB0596	7000201006	E7NN-8501-CB, E7NN-8501-CC, 81863835, 81872290
BMM0596	Colheitadeira TC 57	6 Cil	01/93	C/ polia dupla.	UB0596	7000201006	E7NN-8501-CB, E7NN-8501-CC, 81863835, 81872290
BMM0553	F 11000	Perkins 6357 6 Cil Diesel	01/79 a 12/89	Com polia simples 5 1/2"	UB0553	7000153005	70990563, 70991409, P70991409A
BMM0554	F 11000	Perkins 6357 6 Cil Diesel	01/79 a 12/89	Sem Polia	UB0554	7000152004	70990553X, 70990563X, 70991409X, 7099168X, P70991409AX
BMM0558	F 11000	Perkins 6358 6 Cil Diesel	01/79 a 12/89	Sem polia	UB0558	7000152005	70991410, 70991452, 90991410
BMM0576	F 11000	MWM 229 6 Cil Diesel	01/80 a 12/90		UB0576	7000104000	922507310015, 922987310026, WD5T8501A
BMM0558	F 12000	Perkins 6358 6 Cil Diesel	01/79 a 12/89	Sem polia	UB0558	7000152005	70991410, 70991452, 90991410
BMM0576	F 12000	MWM D229 6 Cil Diesel	01/80 a 12/90		UB0576	7000104000	922507310015, 922987310026, WD5T8501A
BMM0731	F 12000	Cummins 6BT-5.9 6 Cil Diesel	01/76 a 11/86		UB0731	7000452002	3802358, 3802970, BF5X/8501/A
BMM0731	F 12000	Cummins 6BTA-5.9 6 Cil Diesel	01/76 a 11/86		UB0731	7000452002	3802358, 3802970, BF5X/8501/A
BMM0731	F 12000	Cummins 6BTAA-5.9 6 Cil Diesel	01/76 a 11/86		UB0731	7000452002	3802358, 3802970, BF5X/8501/A
BMM0558	F 13000	Perkins 6358 6 Cil Diesel	01/79 a 12/89	Sem polia	UB0558	7000152005	70991410, 70991452, 90991410
BMM0576	F 13000	MWM D229 6 Cil Diesel	01/80 a 12/90		UB0576	7000104000	922507310015, 922987310026, WD5T8501A
BMM0576	F 14000	MWM D229 6 Cil Diesel	01/80 a 12/90		UB0576	7000104000	922507310015, 922987310026, WD5T8501A
BMM0731	F 14000	Cummins 6BT-5.9 6 Cil Diesel	01/76 a 11/86		UB0731	7000452002	3802358, 3802970, BF5X/8501/A
BMM0731	F 14000	Cummins 6BTA-5.9 6 Cil Diesel	01/76 a 11/86		UB0731	7000452002	3802358, 3802970, BF5X/8501/A
BMM0731	F 14000	Cummins 6BTAA-5.9 6 Cil Diesel	01/76 a 11/86		UB0731	7000452002	3802358, 3802970, BF5X/8501/A
BMM0731	F 16000	Cummins 6BT-5.9 6 Cil Diesel	01/76 a 11/86		UB0731	7000452002	3802358, 3802970, BF5X/8501/A
BMM0731	F 16000	Cummins 6BTA-5.9 6 Cil Diesel	01/76 a 11/86		UB0731	7000452002	3802358, 3802970, BF5X/8501/A
BMM0731	F 16000	Cummins 6BTAA-5.9 6 Cil Diesel	01/76 a 11/86		UB0731	7000452002	3802358, 3802970, BF5X/8501/A
BMM0576	F 19000	MWM D229 6 Cil Diesel	01/80 a 12/90		UB0576	7000104000	922507310015, 922987310026, WD5T8501A



CÓDIGO MAGNETI MARELLI	APLICAÇÃO	MOTOR		Obs.:	URBA	INDISA	CÓDIGO ORIGINAL
FORD (cont.)							
BMM0576	F 2000	MWM D229 4 Cil Diesel	01/80 a 12/90		UB0576	7000104000	922507310015, 922987310026, WD5T8501A
BMM0576	F 21000	MWM D229 6 Cil Diesel	01/80 a 12/90		UB0576	7000104000	922507310015, 922987310026, WD5T8501A
BMM0576	F 22000	MWM D229 6 Cil Diesel	01/80 a 12/90		UB0576	7000104000	922507310015, 922987310026, WD5T8501A
BMM0731	F 4000	Cummins 6BT-5.9 6 Cil Diesel	01/76 a 11/86		UB0731	7000452002	3802358, 3802970, BF5X/8501A
BMM0731	F 4000	Cummins 6BTA-5.9 6 Cil Diesel	01/76 a 11/86		UB0731	7000452002	3802358, 3802970, BF5X/8501A
BMM0731	F 4000	Cummins 6BTAA-5.9 6 Cil Diesel	01/76 a 11/86		UB0731	7000452002	3802358, 3802970, BF5X/8501A
BMM0553	F 600	Perkins 6357 6 Cil Diesel	01/69 a 12/81	Com polia simples 5 1/2"	UB0553	7000153005	70990563, 70991409, P70991409A
BMM0554	F 600	Perkins 6357 6 Cil Diesel	01/69	12/81	Sem Polia	UB0554	7000152004 70990553X, 70990563X, 70991409X, 7099168X, P70991409AX
BMM0558	F 700	Perkins 6358 6 Cil Diesel	01/79 a 12/89	Sem polia	UB0558	7000152005	70991410, 70991452, 90991410
BMM0553	F 7000	Perkins 6357 6 Cil Diesel	01/69 a 12/81	Com polia simples de 5 1/2"	UB0553	7000153005	70990563, 70991409, P70991409A
BMM0554	F 7000	Perkins 6357 6 Cil Diesel	01/69 a 12/81	Sem Polia	UB0554	7000152004	70990553X, 70990563X, 70991409X, 7099168X, P70991409AX
BMM0558	F 750	Perkins 6358 6 Cil Diesel	01/79 a 12/89	Sem polia	UB0558	7000152005	70991410, 70991452, 90991410
BMM0576	FB 4000	MWM D229 4 Cil Diesel	01/80 a 12/90		UB0576	7000104000	922507310015, 922987310026, WD5T8501A
BMM0610	Jeep	OM 364 4 Cil	01/80 a 12/90		UB0610	7000401008	3642000101, 3642002001
BMM0610	Jeep	OM 364A 4 Cil	01/80 a 12/90		UB0610	7000401008	3642000101, 3642002001
BMM0594	Trator 5610	4.2	01/86		UB0594	7000201005	E6NN-8501-HB, E6NN-8501-HD
BMM0594	Trator 6610	4.4	01/86		UB0594	7000201005	E6NN-8501-HB, E6NN-8501-HD
BMM0596	Trator 7810	6 Cil	01/90 a 12/93	Com polia dupla	UB0596	7000201006	E7NN-8501-CB, E7NN-8501-CC, 81863835, 81872290
BMM0596	Trator 7830	6 Cil	01/90 a 12/93	Com polia dupla	UB0596	7000201006	E7NN-8501-CB, E7NN-8501-CC, 81863835, 81872290
BMM0596	Trator 8030	6 Cil	01/90 a 12/93	Com polia dupla	UB0596	7000201006	E7NN-8501-CB, E7NN-8501-CC, 81863835, 81872290
BMM0592	Trator 5030	4 Cil	01/87	Com polia dupla Sem tampa	UB0592	7000201004	E6NN-8501-GD, E6NN-8501-CA, 87800109, 87800118
BMM0592	Trator 5630	4 Cil	01/87	Com polia dupla Sem tampa	UB0592	7000201004	E6NN-8501-GD, E6NN-8501-CA, 87800109, 87800118
BMM0592	Trator 6630	4 Cil	01/87	Com polia dupla Sem tampa	UB0592	7000201004	E6NN-8501-GD, E6NN-8501-CA, 87800109, 87800118



Linha de produtos Magneti Marelli Bomba d'água



CÓDIGO MAGNETI MARELLI	APLICAÇÃO	MOTOR		Obs.:	URBA	INDISA	CÓDIGO ORIGINAL
------------------------	-----------	-------	---	-------	------	--------	-----------------

FORD (cont.)

BMM0592	Trator 7610	4 Cil	01/87	Com polia dupla Sem tampa	UB0592	7000201004	E6NN-8501-GD, E6NN-8501-CA, 87800109, 87800118
BMM0592	Trator 7610 (4x4)	4 Cil	01/87	Com polia dupla Sem tampa	UB0592	7000201004	E6NN-8501-GD, E6NN-8501-CA, 87800109, 87800118

HYSTER

BMM0326	8596	Perkins 4236 4 Cil Diesel	01/76 a 01/86	Sem Polia	UB0326	7000152000	70991175X, 70992287X
BMM0326	8676	Perkins 4236 4 Cil Diesel	01/69 a 01/79	Sem Polia	UB0326	7000152000	70991175X, 70992287X
BMM0326	42361	Perkins 4236 4 Cil Diesel	01/69 a 01/86	Sem Polia	UB0326	7000152000	70991175X, 70992287X
BMM0135	110J	GM 250 6 Cil Diesel	01/69 a 12/92		UB0135	7000254000	7330495, 7322682
BMM0135	130J	GM 250 6 Cil Diesel	01/69 a 12/92		UB0135	7000254000	7330495, 7322682
BMM0135	150J	GM 250 6 Cil Diesel	01/69 a 12/92		UB0135	7000254000	7330495, 7322682
BMM0135	40K	GM 151 4 Cil Diesel	01/69 a 12/92		UB0135	7000254000	7330495, 7322682
BMM0135	50K	GM 151 4 Cil Diesel	01/69 a 12/92		UB0135	7000254000	7330495, 7322682
BMM0135	60J	GM 250 6 Cil Diesel	01/69 a 12/92		UB0135	7000254000	7330495, 7322682
BMM0135	70J	GM 250 6 Cil Diesel	01/69 a 12/92		UB0135	7000254000	7330495, 7322682
BMM0135	80J	GM 250 6 Cil Diesel	01/69 a 12/92		UB0135	7000254000	7330495, 7322682
BMM0135	90J	GM 250 6 Cil Diesel	01/69 a 12/92		UB0135	7000254000	7330495, 7322682

IDEAL

BMM0365	Colheitadeira	MB OM 366 6 Cil Diesel	01/80 a 12/90	Com tampa traseira	UB0365	7000400002	3662000401, 3662000701, 3662005901
BMM0365	Colheitadeira	MB OM 366 Turbo 6 Cil Diesel	01/80 a 12/90	Com tampa traseira	UB0365	7000400002	3662000401, 3662000701, 3662005901
BMM0366	Colheitadeira	OM 366 6 Cil Diesel	01/80 a 12/90	Sem Tampa Traseira	UB0366	7000401003	3662000401X, 3662000701X
BMM0366	Colheitadeira	OM 366 Turbo 6 Cil Diesel	01/80 a 12/90	Sem Tampa Traseira	UB0366	7000401003	3662000401X, 3662000701X
BMM0576	Colheitadeira	MWM D225 6 Cil Diesel	01/80 a 12/90		UB0576	7000104000	
BMM0576	Colheitadeira	MWM D226 4 Cil Diesel	01/80 a 12/90		UB0576	7000104000	
BMM0576	Colheitadeira	MWM D229 3 Cil Diesel	01/80 a 12/90		UB0576	7000104000	
BMM0576	Colheitadeira	MWM D229 6 Cil Diesel	01/80 a 12/90		UB0576	7000104000	
BMM0578	Colheitadeira	MWM TD229 EC 6 Cil Diesel	01/80 a 12/90		UB0578	7000104001	
BMM0562	Trator CA1175 / CA 1175 DS (colheitadeira)	PERKINS QB20B - 6354 4/6 cil	Todos	Sem polia	UB0562	7000152006	41313027, 6354141

JI.CASE

BMM0576	60	MWM D222 4 Cil Diesel	01/80 a 12/90		UB0576	7000104000	
---------	----	-----------------------	---------------	--	--------	------------	--

MARCOPLAN

BMM0054	E-300.00	Ford BF 161 6 Cil Diesel	01/60 a 12/72		UB0054	7000204002	643564 e BD4B8501A
BMM0553	E-300.00	Perkins 6357 6 Cil Diesel	01/69 a 12/81	Com polia simples 5 1/2"	UB0553	7000153005	70990563, 70991409, P70991409A
BMM0554	E-300.00	Perkins 6357 6 Cil Diesel	01/69 a 12/81	Sem Polia	UB0554	7000152004	70990553X, 70990563X, 70991409X, 7099168X, P70991409AX
BMM0553	E-700.00	Perkins 6357 6 Cil Diesel	01/69 A 12/81	Com polia simples 5 1/2"	UB0553	7000153005	70990563, 70991409, P70991409A



CÓDIGO MAGNETI MARELLI	APLICAÇÃO	MOTOR		Obs.:	URBA	INDISA	CÓDIGO ORIGINAL
------------------------	-----------	-------	---	-------	------	--------	-----------------

MARCOPLAN (cont.)

BMM0554	E-700.00	Perkins 6357 6 Cil Diesel	01/69 A 12/81	Sem Polia	UB0554	7000152004	70990553X, 70990563X, 70991409X, 7099168X, P70991409AX
---------	----------	---------------------------	---------------	-----------	--------	------------	--

MASSEY FERGUSON

BMM0562	Colheitadeira 3640 / 3640T / 5650 / 5650T	PERKINS QB20B - 6354 4/6 cil	Todos	Sem polia	UB0562	7000152006	41313027, 6354141
BMM0554	MF 3366	Perkins 6357 6 Cil Diesel	01/70 a 12/80	Sem Polia	UB0554	7000152004	70990553X, 70990563X, 70991409X, 7099168X, P70991409AX
BMM0555	MF 3366	Perkins 6.357 6 Cil Diesel	01/70 a 12/80	Com polia simples 4 5/8"	UB0555	7000153002	70990553
BMM0329	MF 5265	Perkins 4203 4 Cil Diesel	01/66 a 12/76	Com Polia	UB0329	7000153001	70991412
BMM0330	MF 5265	Perkins 4203 4 Cil Diesel	01/66 a 12/76	Sem Polia	UB0330	7000152001	70990329X
BMM0329	MF 65	Perkins 4203 4 Cil Diesel	01/66 a 12/76	Com Polia	UB0329	7000153001	70991412
BMM0330	MF 65	Perkins 4203 4 Cil Diesel	01/66 a 12/76	Sem Polia	UB0330	7000152001	70990329X
BMM0325	MF 85	Perkins 4236 4 Cil Diesel	01/76 a 12/86	Com Polia	UB0325	7000153003	70992287
BMM0325	MF 85	Perkins 4248 4 Cil Diesel	01/76 a 12/86	Com Polia	UB0325	7000153003	70992287
BMM0326	MF 85	Perkins 4236 4 Cil Diesel	01/76 a 12/86	Sem Polia	UB0326	7000152000	70991175X, 70992287X
BMM0326	MF 85	Perkins 4248 4 Cil Diesel	01/76 a 12/86	Sem Polia	UB0326	7000152000	70991175X, 70992287X
BMM0554	MF 95	Perkins 6357 6 Cil Diesel	01/70 a 12/80	Sem Polia	UB0554	7000152004	70990553X, 70990563X, 70991409X, 7099168X, P70991409AX
BMM0555	MF 95	Perkins 6.357 6 Cil Diesel	01/70 a 12/80	Com polia simples 4 5/8"	UB0555	7000153002	70990553

MAXION

BMM2008	Trator MF 235	Perkins D-3152 - 3 Cil	01/62 a ...	Sem polia	-	7000152008	70991414, 70990318
BMM2008	Trator MF 250	Perkins D-3152 - 3 Cil	01/62	...	Sem polia	-	7000152008 70991414, 70990318
BMM2009	Trator MF 275	Perkins 4000 Turbo / 4236 Turbo - 4 Cil	Todos	Sem polia	-	7000152009	70992424, 4236254
BMM2009	Trator MF 290	Perkins 4000 Turbo / 4236 Turbo - 4 Cil	Todos	Sem polia	-	7000152009	70992424, 4236254
BMM2009	Trator MF 292	Perkins 4000 Turbo / 4236 Turbo - 4 Cil	Todos	Sem polia	-	7000152009	70992424, 4236254
BMM0562	Trator MF 296 / 296.4CH - SH / 297 / 299	PERKINS QB20B - 6354 4/6 cil 4236 Turbo - 4 Cil	Todos	Sem polia	UB0562	7000152006	41313027, 6354141
BMM2008	Trator MF 35	Perkins D-3152 - 3 Cil	01/62 a ...	Sem polia	-	7000152008	70991414, 70990318
BMM2008	Trator MF 50	Perkins D-3152 - 3 Cil	01/62 a ...	Sem polia	-	7000152008	70991414, 70990318
BMM2008	Trator MF 50X	Perkins D-3152 - 3 Cil	01/62 a ...	Sem polia	-	7000152008	70991414, 70990318
BMM2008	Trator MF 55X	Perkins D-3152 - 3 Cil	01/62 a ...	Sem polia	-	7000152008	70991414, 70990318
BMM2009	Trator MF 610	Perkins 4000 Turbo / 4236 Turbo - 4 Cil	Todos	Sem polia	-	7000152009	70992424, 4236254
BMM2009	Trator MF 620	Perkins 4000 Turbo / 4236 Turbo - 4 Cil	Todos	Sem polia	-	7000152009	70992424, 4236254
BMM2009	Trator MF 750	Perkins 4000 Turbo / 4236 Turbo - 4 Cil	Todos	Sem polia	-	7000152009	70992424, 4236254
BMM0562	Trator MF 9110 / 9130 Turbo / 9150 / 9170	PERKINS QB20B - 6354 4/6 cil	Todos	Sem polia	UB0562	7000152006	41313027, 6354141

MERCEDES-BENZ

BMM0608	608	OM 314 4 Cil Diesel	01/72 a 12/90		UB0608	7000401000	3142000601 e 3142002901
---------	-----	---------------------	---------------	--	--------	------------	----------------------------



Linha de produtos Magneti Marelli
Bomba d'água



CÓDIGO MAGNETI MARELLI	APLICAÇÃO	MOTOR		Obs.:	URBA	INDISA	CÓDIGO ORIGINAL
MERCEDES-BENZ (cont.)							
BMM0610	709	OM 364 4 Cil Diesel	01/90 a 01/95		UB0610	7000401008	3642000101, 3642002001
BMM0380	712	OM 904LA 4 Cil Diesel	01/98 a 12/06		UB0380	7000401013	9042000201, 9042000701, 9042001901, 9042002001, 9042002201, 9042002501
BMM0610	712	OM 364A 4 Cil Diesel	01/90 a 01/95		UB0610	7000401008	3642000101, 3642002001
BMM0610	809	OM 364 4 Cil Diesel	01/90 a 12/98		UB0610	7000401008	3642000101, 3642002001
BMM0610	812	OM 364 4 Cil Diesel	01/90 a 12/98		UB0610	7000401008	3642000101, 3642002001
BMM0610	812	OM 364A 4 Cil Diesel	01/90 a 01/95		UB0610	7000401008	3642000101, 3642002001
BMM0610	912	OM 364A 4 Cil Diesel	01/90 a 12/06		UB0610	7000401008	3642000101, 3642002001
BMM0380	914	OM 904LA 4 Cil Diesel	01/98 a 12/06		UB0380	7000401013	9042000201, 9042000701, 9042001901, 9042002001, 9042002201, 9042002501
BMM0610	914	OM 364A 4 Cil Diesel	01/81 a 12/06		UB0610	7000401008	3642000101, 3642002001
BMM0313	1111	OM 352 6 Cil Diesel	01/69 a 12/70	Com Tampa, Rotor com diam. 88mm	UB0313	7000400000	3522003801, 3522003811, 3522009401
BMM0314	1111	OM 352 6 Cil Diesel	01/69 a 12/70	Sem Tampa	UB0314	7000401001	3522003801, 3522003801X, 3522009401, 3522009401X
BMM0313	1113	OM 352 6 Cil Diesel	01/69 a 12/70	Com Tampa, Rotor com diam. 88mm	UB0313	7000400000	3522003801, 3522003811, 3522009401
BMM0314	1113	OM 352 6 Cil Diesel	01/69 a 12/70	Sem Tampa	UB0314	7000401001	3522003801, 3522003801X, 3522009401, 3522009401X
BMM0315	1113	OM 352A 6 Cil Diesel	01/86 a 12/89	Com Tampa, Rotor Diam. 95 mm	UB0315	7000400001	3532000301
BMM0316	1113	OM 352A 6 Cil Diesel	01/86 a 12/89	Sem Tampa, Rotor Diam. 95 mm	UB0316	7000401002	3532000301X
BMM0362	1113	OM 352 6 Cil Diesel	01/74 a 12/89	Rebaixado s/ tampa Rotor c/ diâmetro 87,5 mm	UB0362	7000401006	3522005401X, 3522009601X
BMM0363	1113	OM 352A 6 Cil Diesel	01/74 a 12/89	Rebaixado c/ tampa Rotor c/ diâm. 95 mm	UB0363	7000400004	3532001101
BMM0364	1113	OM 352A 6 Cil Diesel	01/74 a 12/89	Rebaixado s/ tampa Rotor c/ diâm. 95 mm	UB0364	7000401007	3532001101X, 353200111X
BMM0313	1116	OM 352 6 Cil Diesel	01/69 a 12/70	Com Tampa, Rotor c/ diam. 88mm	UB0313	7000400000	3522003801, 3522003811, 3522009401
BMM0314	1116	OM 352 6 Cil Diesel	01/69 a 12/70	Sem Tampa	UB0314	7000401001	3522003801, 3522003801X, 3522009401, 3522009401X
BMM0315	1116	OM 352A 6 Cil Diesel	01/86 a 12/89	C/ Tampa, Rotor Diam. 95 mm	UB0315	7000400001	3532000301



CÓDIGO MAGNETI MARELLI	APLICAÇÃO	MOTOR		Obs.:	URBA	INDISA	CÓDIGO ORIGINAL
MERCEDES-BENZ (cont.)							
BMM0316	1116	OM 352A 6 Cil Diesel	01/86 a 12/89	Sem Tampa, Rotor Diam. 95 mm	UB0316	7000401002	3532000301X
BMM0365	1214	OM 366/366A 6 Cil Diesel	01/89 a 12/99	Com tampa traseira	UB0365	7000400002	3662000401, 3662000701, 3662005901
BMM0366	1214	OM 366/366A 6 Cil Diesel	01/89 a 12/99	Sem Tampa Traseira	UB0366	7000401003	3662000401X, 3662000701X
BMM0380	1215	OM 904LA 4 Cil Diesel	01/98 a 12/06		UB0380	7000401013	9042000201, 9042000701, 9042001901, 9042002001, 9042002201, 9042002501
BMM0365	1218	OM 366/366A 6 Cil Diesel	01/89 a 12/99	Com tampa traseira	UB0365	7000400002	3662000401, 3662000701, 3662005901
BMM0366	1218	OM 366/366A 6 Cil Diesel	01/89 a 12/99	Sem Tampa Traseira	UB0366	7000401003	3662000401X, 3662000701X
BMM0380	1218	OM 904LA 4 Cil Diesel	01/98 a 12/06		UB0380	7000401013	9042000201, 9042000701, 9042001901, 9042002001, 9042002201, 9042002501
BMM0313	1313	OM 352 6 Cil Diesel	01/69 a 12/70	Com Tampa, Rotor com diam. 88mm	UB0313	7000400000	3522003801, 3522003811, 3522009401
BMM0314	1313	OM 352 6 Cil Diesel	01/69 a 12/70	Sem Tampa	UB0314	7000401001	3522003801, 3522003801X, 3522009401, 3522009401X
BMM0315	1313	OM 352A 6 Cil Diesel	01/86 a 12/89	Com Tampa, Rotor Diam. 95 mm	UB0315	7000400001	3532000301
BMM0316	1313	OM 352A 6 Cil Diesel	01/86 a 12/89	Sem Tampa, Rotor Diam. 95 mm	UB0316	7000401002	3532000301X
BMM0365	1315	OM 366/366A 6 Cil Diesel	01/89 a 12/96	Com tampa traseira	UB0365	7000400002	3662000401, 3662000701, 3662005901
BMM0366	1315	OM 366/366A 6 Cil Diesel	01/89 a 12/96	Sem Tampa Traseira.	UB0366	7000401003	3662000401X, 3662000701X
BMM0313	1316	OM 352 6 Cil Diesel	01/69 a 12/70	Com Tampa, Rotor com diam. 88mm	UB0313	7000400000	3522003801, 3522003811, 3522009401
BMM0314	1316	OM 352 6 Cil Diesel	01/69 a 12/70	Sem Tampa	UB0314	7000401001	3522003801, 3522003801X, 3522009401, 3522009401X
BMM0315	1316	OM 352A 6 Cil Diesel	01/86 a 12/89	Com Tampa, Rotor Diam. 95 mm	UB0315	7000400001	3532000301
BMM0316	1316	OM 352A 6 Cil Diesel	01/86 a 12/89	Sem Tampa, Rotor Diam. 95 mm	UB0316	7000401002	3532000301X
BMM0365	1318	OM 366/366A 6 Cil Diesel	01/89 a 12/99	Com tampa traseira	UB0365	7000400002	3662000401, 3662000701, 3662005901
BMM0366	1318	OM 366/366A 6 Cil Diesel	01/89 a 12/99	Sem Tampa Traseira	UB0366	7000401003	3662000401X, 3662000701X
BMM0365	1414	OM 366/366A 6 Cil Diesel	01/89 a 12/99	Com tampa Traseira	UB0365	7000400002	3662000401, 3662000701, 3662005901
BMM0366	1414	OM 366/366A 6 Cil Diesel	01/89 a 12/99	Sem Tampa Traseira	UB0366	7000401003	3662000401X, 3662000701X



Linha de produtos Magneti Marelli
Bomba d'água



CÓDIGO MAGNETI MARELLI	APLICAÇÃO	MOTOR		Obs.:	URBA	INDISA	CÓDIGO ORIGINAL
MERCEDES-BENZ (cont.)							
BMM0365	1418	OM 366/366A 6 Cil Diesel	01/89 a 12/99	Com tampa traseira.	UB0365	7000400002	3662000401, 3662000701, 3662005901
BMM0366	1418	OM 366/366A 6 Cil Diesel	01/89 a 12/99	Sem Tampa Traseira	UB0366	7000401003	3662000401X, 3662000701X
BMM0380	1418	OM 904LA 4 Cil Diesel	01/98 a 12/06		UB0380	7000401013	9042000201, 9042000701, 9042001901, 9042002001, 9042002201, 9042002501
BMM0313	1513	OM 352 6 Cil Diesel	01/69 a 12/70	Com Tampa, Rotor com diam. 88mm	UB0313	7000400000	3522003801, 3522003811, 3522009401
BMM0314	1513	OM 352 6 Cil Diesel	01/69 a 12/70	Sem Tampa	UB0314	7000401001	3522003801, 3522003801X, 3522009401, 3522009401X
BMM0315	1513	OM 352A 6 Cil Diesel	01/86 a 12/89	Com Tampa, Rotor Diam. 95 mm	UB0315	7000400001	3532000301
BMM0316	1513	OM 352A 6 Cil Diesel	01/86 a 12/89	Sem Tampa, Rotor Diam. 95 mm	UB0316	7000401002	3532000301X
BMM0313	1516	OM 352 6 Cil Diesel	01/69 a 12/70	Com Tampa, Rotor com diam. 88mm	UB0313	7000400000	3522003801, 3522003811, 3522009401
BMM0314	1516	OM 352 6 Cil Diesel	01/69 a 12/70	Sem Tampa	UB0314	7000401001	3522003801, 3522003801X, 3522009401, 3522009401X
BMM0315	1516	OM 352A 6 Cil Diesel	01/86 a 12/89	Com Tampa, Rotor Diam. 95 mm	UB0315	7000400001	3532000301
BMM0316	1516	OM 352A 6 Cil Diesel	01/86 a 12/89	Sem Tampa, Rotor Diam. 95 mm	UB0316	7000401002	3532000301X
BMM0355	1517	OM 355 5/6 Cil Diesel	01/79 a 12/92	Rotor 115 mm	UB0355	7000401004	3452007101
BMM0355	1519	OM 355 5/6 Cil Diesel	01/79 a 12/92	Rotor 115 mm	UB0355	7000401004	3452007101
BMM0365	1614	OM 366/366A 6 Cil Diesel	01/89 a 12/99	Com tampa traseira	UB0365	7000400002	3662000401, 3662000701, 3662005901
BMM0366	1614	OM 366/366A 6 Cil Diesel	01/89 a 12/99	Sem Tampa Traseira	UB0366	7000401003	3662000401X, 3662000701X
BMM0365	1618	OM 366/366A 6 Cil Diesel	01/89 a 12/99	Com tampa traseira	UB0365	7000400002	3662000401, 3662000701, 3662005901
BMM0366	1618	OM 366/366A 6 Cil Diesel	01/89 a 12/99	Sem Tampa Traseira	UB0366	7000401003	3662000401X, 3662000701X
BMM0579	1618	MWM Série 10 Turbo 6 Cil Diesel	01/92 a 12/06		UB0579	7000105001	
BMM0365	1620	OM 366/366A 6 Cil Diesel	01/89 a 12/99	Com tampa traseira	UB0365	7000400002	3662000401, 3662000701, 3662005901
BMM0366	1620	OM 366/366A 6 Cil Diesel	01/89 a 12/99	Sem Tampa Traseira	UB0366	7000401003	3662000401X, 3662000701X
BMM0365	1621	OM 366/366A 6 Cil Diesel	01/89 a 12/99	Com tampa traseira	UB0365	7000400002	3662000401, 3662000701, 3662005901
BMM0366	1621	OM 366/366A 6 Cil Diesel	01/89 a 12/99	Sem Tampa Traseira	UB0366	7000401003	3662000401X, 3662000701X
BMM0380	1622	OM 924LA 4 Cil Diesel	01/98 a 12/06		UB0380	7000401013	9042000201, 9042000701, 9042001901, 9042002001, 9042002201, 9042002501



CÓDIGO MAGNETI MARELLI	APLICAÇÃO	MOTOR		Obs.:	URBA	INDISA	CÓDIGO ORIGINAL
MERCEDES-BENZ (cont.)							
BMM0365	1714	OM 366/366A 6 Cil Diesel	01/89 a 12/99	Com tampa traseira	UB0365	7000400002	3662000401, 3662000701, 3662005901
BMM0366	1714	OM 366/366A 6 Cil Diesel	01/89 a 12/99	Sem Tampa Traseira	UB0366	7000401003	3662000401X, 3662000701X
BMM0365	1718	OM 366/366A 6 Cil Diesel	01/89 a 12/99	Com tampa traseira	UB0365	7000400002	3662000401, 3662000701, 3662005901
BMM0366	1718	OM 366/366A 6 Cil Diesel	01/89 a 12/99	Sem Tampa Traseira	UB0366	7000401003	3662000401X, 3662000701X
BMM0380	1718	OM 904LA 4 Cil Diesel	01/98 a 12/07		UB0380	7000401013	9042000201, 9042000701, 9042001901, 9042002001, 9042002201, 9042002501
BMM0365	1721	OM 366/366A 6 Cil Diesel	01/89 a 12/99	Com tampa traseira	UB0365	7000400002	3662000401, 3662000701, 3662005901
BMM0366	1721	OM 366/366A 6 Cil Diesel	01/89 a 12/99	Sem Tampa Traseira	UB0366	7000401003	3662000401X, 3662000701X
BMM0357	1924	OM 355 Turbo 5/6 Cil Diesel	01/80 a 12/92	Rotor com Diam.120,5 mm	UB0357	7000401005	3452000201
BMM0357	1929	OM 355 Turbo 5/6 Cil Diesel	01/80 a 12/92	Rotor com Diam.120,5 mm	UB0357	7000401005	3452000201
BMM0313	2013	OM 352 6 Cil Diesel	01/69 a 12/70	Com Tampa, Rotor com diam. 88mm	UB0313	7000400000	3522003801, 3522003811, 3522009401
BMM0314	2013	OM 352 6 Cil Diesel	01/69 a 12/70	Sem Tampa	UB0314	7000401001	3522003801, 3522003801X, 3522009401, 3522009401X
BMM0315	2013	OM 352A 6 Cil Diesel	01/86 a 12/89	Com Tampa, Rotor Diam. 95 mm	UB0315	7000400001	3532000301
BMM0316	2013	OM 352A 6 Cil Diesel	01/86 a 12/89	Sem Tampa, Rotor Diam. 95 mm	UB0316	7000401002	3532000301X
BMM0313	2016	OM 352 6 Cil Diesel	01/69 a 12/70	Com Tampa, Rotor com diam. 88mm	UB0313	7000400000	3522003801, 3522003811, 3522009401
BMM0314	2016	OM 352 6 Cil Diesel	01/69 a 12/70	Sem Tampa	UB0314	7000401001	3522003801, 3522003801X, 3522009401, 3522009401X
BMM0315	2016	OM 352A 6 Cil Diesel	01/86 a 12/89	Com Tampa, Rotor Diam. 95 mm	UB0315	7000400001	3532000301
BMM0316	2016	OM 352A 6 Cil Diesel	01/86 a 12/89	Sem Tampa, Rotor Diam. 95 mm	UB0316	7000401002	3532000301X
BMM0313	2213	OM 352 6 Cil Diesel	01/69 a 12/70	Com Tampa, Rotor com diam. 88mm	UB0313	7000400000	3522003801, 3522003811, 3522009401
BMM0314	2213	OM 352 6 Cil Diesel	01/69 a 12/70	Sem Tampa	UB0314	7000401001	3522003801, 3522003801X, 3522009401, 3522009401X
BMM0315	2213	OM 352A 6 Cil Diesel	01/86 a 12/89	Com Tampa, Rotor Diam. 95 mm	UB0315	7000400001	3532000301
BMM0316	2213	OM 352A 6 Cil Diesel	01/86 a 12/89	Sem Tampa, Rotor Diam. 95 mm	UB0316	7000401002	3532000301X



Linha de produtos Magneti Marelli
Bomba d'água



CÓDIGO MAGNETI MARELLI	APLICAÇÃO	MOTOR		Obs.:	URBA	INDISA	CÓDIGO ORIGINAL
MERCEDES-BENZ (cont.)							
BMM0313	2216	OM 352 6 Cil Diesel	01/69 a 12/70	Com Tampa, Rotor com diam. 88mm	UB0313	7000400000	3522003801, 3522003811, 3522009401
BMM0314	2216	OM 352 6 Cil Diesel	01/69 a 12/70	Sem Tampa	UB0314	7000401001	3522003801, 3522003801X, 3522009401, 3522009401X
BMM0315	2216	OM 352A 6 Cil Diesel	01/86 a 12/89	Com Tampa, Rotor Diam. 95 mm	UB0315	7000400001	3532000301
BMM0316	2216	OM 352A 6 Cil Diesel	01/86 a 12/89	Sem Tampa, Rotor Diam. 95 mm	UB0316	7000401002	3532000301X
BMM0355	2219	OM 355 5/6 Cil Diesel	01/79 a 12/92	Rotor 115 mm	UB0355	7000401004	3452007101
BMM0365	2314	OM 366/366A 6 Cil Diesel	01/89 a 12/99	Com tampa traseira	UB0365	7000400002	3662000401, 3662000701, 3662005901
BMM0366	2314	OM 366/366A 6 Cil Diesel	01/89 a 12/99	Sem Tampa Traseira	UB0366	7000401003	3662000401X, 3662000701X
BMM0365	2318	OM 366/366A 6 Cil Diesel	01/89 a 12/99	Com tampa traseira	UB0365	7000400002	3662000401, 3662000701, 3662005901
BMM0366	2318	OM 366/366A 6 Cil Diesel	01/89 a 12/99	Sem Tampa Traseira	UB0366	7000401003	3662000401X, 3662000701X
BMM0365	2418	OM 366/366A 6 Cil Diesel	01/89 a 12/99	Com tampa traseira	UB0365	7000400002	3662000401, 3662000701, 3662005901
BMM0366	2418	OM 366/366A 6 Cil Diesel	01/89 a 12/99	Sem Tampa Traseira	UB0366	7000401003	3662000401X, 3662000701X
BMM0380	2423	OM 904LA 4 Cil Diesel	01/98 a 12/06		UB0380	7000401013	9042000201, 9042000701, 9042001901, 9042002001, 9042002201, 9042002501
BMM0380	2428	OM 906LA 4 Cil Diesel	01/98 a 12/06		UB0380	7000401013	9042000201, 9042000701, 9042001901, 9042002001, 9042002201, 9042002501
BMM0372	1628L-59 / 1635L-30 / 1635L-59	OM447A / OM447LA / OM449A / OM449LA (5/6 cil)	Todos	S/ tampa tras. Com polia de 169 mm	UB0372	7000401010	4752000001, 4752000101, 4752000201
BMM0372	1935 / 1941/ 2325 / 2635	OM447A / OM447LA / OM449A / OM449LA (5/6 cil)	Todos	S/ tampa tras. C/ polia 169mm	UB0372	7000401010	4752000001, 4752000101, 4752000201
BMM0372	400RSE / 400UP / 400 UPA / 1315 / 1318 / 1420 / 1620	OM447A / OM447LA / OM449A / OM449LA (5/6 cil)	Todos	S/ tampa tras. C/ polia 169mm	UB0372	7000401010	4752000001, 4752000101, 4752000201
BMM0367	Diversos	OM 366LA Intercooler 6 Cil Diesel	01/96 a 12/05	C/ tampa. C/ rolamento reforçado.	UB0367	7000400006	3662006801, 3762000901
BMM0368	Diversos	OM 366LA Intercooler 6 Cil Diesel	01/96 a 12/05	Sem tampa. C/ rolamento reforçado.	UB0368	7000401012	3662006801, 3662006801X, 3762000901X
BMM0370	Diversos	OM 366 Ecológico 6 Cil Diesel	01/80 a 12/90	Sem tampa.	UB0370	7000401011	3762000001X, 3762000501, 3762000601X
BMM0372	L / LB / LK / LS - 1625 / 1630 / 1632 / 1634-45	OM447A / OM447LA / OM449A / OM449LA (5/6 cil)	Todos	S/ tampa tras. C/ polia 169mm.	UB0372	7000401010	4752000001, 4752000101, 4752000201
BMM0373	LK2638-40 6x4 / LS2638-40 6x4	OM 457 6 Cil Diesel	01/90 a 12/06	Eletrônico Euro II Conama Fase IV. C/ rotor 136mm.	UB0373	7000401014	4572000101, 4572000201, 4572004701, 4572007001, 4032004701



CÓDIGO MAGNETI MARELLI	APLICAÇÃO	MOTOR		Obs.:	URBA	INDISA	CÓDIGO ORIGINAL
MERCEDES-BENZ (cont.)							
BMM0380	LO914	OM 904LA 4 Cil Diesel	01/98 a 12/06		UB0380	7000401013	9042000201, 9042000701, 9042001901, 9042002001, 9042002201, 9042002501
BMM0373	LS1938-46 / LS1938S-37/	OM 457 6 Cil Diesel	01/90 a 12/06	Eletrônico Euro II Conama Fase IV. C/ rotor 136 mm.	UB0373	7000401014	4572000101, 4572000201, 4572004701, 4572007001, 4032004701
BMM0372	O / OF / OH / OHL - 371/ 371R / 371UP / 400RSD	OM447A / OM447LA / OM449A / OM449LA (5/6 cil)	Todos	S/ tampa tras. C/ polia 169mm	UB0372	7000401010	4752000001, 4752000101, 4752000201
BMM0313	O352	OM 352 6 Cil Diesel	01/70 a 12/89	C/ Tampa, Rotor c/ diam. 88mm	UB0313	7000400000	3522003801, 3522003811, 3522009401
BMM0314	O352	OM 352 6 Cil Diesel	01/70 a 12/89	Sem Tampa	UB0314	7000401001	3522003801, 3522003801X, 3522009401, 3522009401X
BMM0315	O352	OM 352A 6 Cil Diesel	01/86 a 12/89	C/ Tampa, Rotor Diam. 95 mm	UB0315	7000400001	3532000301
BMM0316	O352	OM 352A 6 Cil Diesel	01/86 a 12/89	S/ Tampa, Rotor Diam. 95 mm	UB0316	7000401002	3532000301X
BMM0357	O355	OM 355 Turbo 5/6 Cil Diesel	01/80 a 12/92	Rotor c/ Diam. 120,5 mm	UB0357	7000401005	3452000201
BMM0362	O362	OM 352 6 Cil Diesel	01/74 a 12/89	Rebaixado s/ tampa. Rotor c/ diam. 87,5mm	UB0362	7000401006	3522005401X, 3522009601X
BMM0363	O362	OM 352A 6 Cil Diesel	01/74 a 12/89	Rebaixado c/ tampa. Rotor c/ diam. 95mm	UB0363	7000400004	3532001101
BMM0364	O362	OM 352A 6 Cil Diesel	01/74 a 12/89	Rebaixado s/ tampa. Rotor c/ diam. 95 mm.	UB0364	7000401007	3532001101X, 3532001111X
BMM0355	O364	OM 355 5/6 Cil Diesel	01/80 a 12/92	Rotor 115 mm	UB0355	7000401004	3452007101
BMM0357	O364	OM 355 Turbo 5/6 Cil Diesel	01/80 a 12/92	Rotor c/ diam. 120,5 mm	UB0357	7000401005	3452000201
BMM0362	O364	OM 352 5/6 Cil Diesel	01/82 a 12/89	Rebaixado s/ tampa. Rotor c/ diam. 87,5mm	UB0362	7000401006	3522005401X, 3522009601X
BMM0363	O364	OM 352A 5/6 Cil Diesel	01/82 a 12/89	Rebaixado c/ tampa. Rotor c/ diam. 95mm	UB0363	7000400004	3532001101
BMM0364	O364	OM 352A 5/6 Cil Diesel	01/82 a 12/89	Rebaixado s/ tampa. Rotor c/ diâm. 95 mm.	UB0364	7000401007	3532001101X, 3532001111X
BMM0365	O371	OM 366/366A 6 Cil Diesel	01/89 a 12/99	C/ tampa tras.	UB0365	7000400002	3662000401, 3662000701, 3662005901
BMM0366	O371	OM 366/366A 6 Cil Diesel	01/89 a 12/99	S/ Tampa Tras.	UB0366	7000401003	3662000401X, 3662000701X
BMM0373	O-400RSD / O-400RSE / O-400UPA	OM 457 6 Cil Diesel	01/90 a 12/06	Eletrônico Euro II Conama Fase IV. C/ rotor 136mm.	UB0373	7000401014	4572000101, 4572000201, 4572004701, 4572007001, 4032004701
BMM0380	O500	OM 906LA 4 Cil Diesel	01/98 a 12/06		UB0380	7000401013	9042000201, 9042000701, 9042001901, 9042002001, 9042002201, 9042002501
BMM0380	O500M	OM 906LA 4 Cil Diesel	01/98 a 12/06		UB0380	7000401013	9042000201,



Linha de produtos Magneti Marelli
Bomba d'água



CÓDIGO MAGNETI MARELLI	APLICAÇÃO	MOTOR		Obs.:	URBA	INDISA	CÓDIGO ORIGINAL
MERCEDES-BENZ (cont.)							
							9042000701, 9042001901, 9042002001, 9042002201, 9042002501
BMM0380	O500R	OM 906LA 4 Cil Diesel	01/98 a 12/06		UB0380	7000401013	9042000201, 9042000701, 9042001901, 9042002001, 9042002201, 9042002501
BMM0380	O500U	OM 906LA 4 Cil Diesel	01/98 a 12/06		UB0380	7000401013	9042000201, 9042000701, 9042001901, 9042002001, 9042002201, 9042002501
BMM0362	OF1113	OM 352 6 Cil Diesel	01/82 a 12/89	Rebaixado s/ tampa. Rotor c/ diam 87,5mm	UB0362	7000401006	3522005401X, 3522009601X
BMM0363	OF1113	OM 352A 6 Cil Diesel	01/82 a 12/89	Rebaixado c/ tampa. Rotor c/ diam. 95mm	UB0363	7000400004	3532001101
BMM0364	OF1113	OM 352A 6 Cil Diesel	01/82 a 12/89	Rebaixado s/ tampa. Rotor c/ diam. 95 mm.	UB0364	7000401007	3532001101X, 353200111X
BMM0365	OF1115	OM 366/366A 6 Cil Diesel	01/89 a 12/99	C/ tampa tras.	UB0365	7000400002	3662000401, 3662000701, 3662005901
BMM0366	OF1115	OM 366/366A 6 Cil Diesel	01/89 a 12/99	S/ Tampa Tras.	UB0366	7000401003	3662000401X, 3662000701X
BMM0362	OF1313	OM 352 6 Cil Diesel	01/74 a 12/89	Rebaixado s/ tampa. Rotor c/ diam. 87,5mm	UB0362	7000401006	3522005401X, 3522009601X
BMM0363	OF1313	OM 352A 6 Cil Diesel	01/74 a 12/89	Rebaixado c/ tampa. Rotor c/ diam. 95 mm	UB0363	7000400004	3532001101
BMM0364	OF1313	OM 352A 6 Cil Diesel	01/74 a 12/89	Rebaixado s/ tampa. Rotor c/ diam. 95 mm.	UB0364	7000401007	3532001101X, 353200111X
BMM0365	OF1313	OM 366/366A 6 Cil Diesel	01/89 a 12/99	C/ tampa tras.	UB0365	7000400002	3662000401, 3662000701, 3662005901
BMM0366	OF1313	OM 366/366A 6 Cil Diesel	01/89 a 12/99	S/ Tampa Tras.	UB0366	7000401003	3662000401X, 3662000701X
BMM0365	OF1318	OM 366/366A 6 Cil Diesel	01/89 a 12/99	C/ tampa tras.	UB0365	7000400002	3662000401, 3662000701, 3662005901
BMM0366	OF1318	OM 366/366A 6 Cil Diesel	01/89 a 12/99	S/ Tampa Tras.	UB0366	7000401003	3662000401X, 3662000701X
BMM0380	OF1417	OM 904LA 4 Cil Diesel	01/98 a 12/06		UB0380	7000401013	9042000201, 9042000701, 9042001901, 9042002001, 9042002201, 9042002501
BMM0369	OF1721	OM 366 Ecológico 6 Cil Diesel	01/80 a 12/90	Com Tampa.	UB0369	7000400005	3662005601, 3762000001, 3762000501, 3762000601, 3762000701
BMM0362	OH1313	OM 352 6 Cil Diesel	01/82 a 12/89	Rebaixado s/ tampa. Rotor c/ diam. 87,5mm	UB0362	7000401006	3522005401X, 3522009601X
BMM0363	OH1313	OM 352A 6 Cil Diesel	01/82 a 12/89	Rebaixado	UB0363	7000400004	3532001101



CÓDIGO MAGNETI MARELLI	APLICAÇÃO	MOTOR		Obs.:	URBA	INDISA	CÓDIGO ORIGINAL
------------------------	-----------	-------	---	-------	------	--------	-----------------

MERCEDES-BENZ (cont.)

					c/ tampa. Rotor c/ diam. 95mm		
BMM0364	OH1313	OM 352A 6 Cil Diesel	01/82 a 12/89	Rebaixado s/ tampa. Rotor c/ diam. 95mm.	UB0364	7000401007	3532001101X, 353200111X
BMM0362	OH1316	OM 352 6 Cil Diesel	01/82 a 12/89	Rebaixado s/ tampa. Rotor c/ diam. 87,5mm	UB0362	7000401006	3522005401X, 3522009601X
BMM0363	OH1316	OM 352A 6 Cil Diesel	01/82 a 12/89	Rebaixado c/ tampa. Rotor c/ diam. 95mm	UB0363	7000400004	3532001101
BMM0364	OH1316	OM 352A 6 Cil Diesel	01/82 a 12/89	Rebaixado s/ tampa. Rotor c/ diam. 95mm.	UB0364	7000401007	3532001101X, 353200111X
BMM0365	OH1317	OM 366/366A 6 Cil Diesel	01/89 a 12/99	C/ tampa tras.	UB0365	7000400002	3662000401, 3662000701, 3662005901
BMM0366	OH1317	OM 366/366A 6 Cil Diesel	01/89 a 12/99	S/ Tampa Tras.	UB0366	7000401003	3662000401X, 3662000701X
BMM0355	OH1419	OM 355 5/6 Cil Diesel	01/79 a 12/92	Rotor 115 mm	UB0355	7000401004	3452007101
BMM0577	MWM	4.2 Sprint Turbo 4 Cil Diesel	01/99 a 12/06	Engrenagem 15°	UB0577	7000105002	

MWM

BMM0577	MWM	Sprint 4 Cil Diesel	01/85 a 12/06	Engrenagem 15°	UB0577	7000105002	
BMM0578	MWM	TD229 EC 6 Cil Diesel	01/80 a 12/90		UB0578	7000104001	
BMM0579	MWM	Série 10 4 Cil Diesel	01/80 a 12/90		UB0579	7000105001	
BMM0579	MWM	Série 10 6 Cil Diesel	01/80 a 12/90		UB0579	7000105001	
BMM0562	Colheitadeira Maxion MF 3640 /	QB20B - 6354 4/6 cil	Todos	Sem polia.	UB0562	7000152006	41313027, 6354141

PERKINS

		3640T / 5650 / 5650T					
BMM0318	PERKINS	3152 3 Cil Diesel	01/62 a 12/72	Com Polia	UB0318	7000153000	70990318, 70991414
BMM0320	PERKINS	AD 3152 3 Cil Diesel	01/89 a 12/99	Com Polia	UB0320	7000153008	70992200
BMM0324	PERKINS	4236 4 Cil Diesel	01/82 a 12/85	Com Polia	UB0324	7000153004	70992425
BMM0325	PERKINS	Perkins 4248 4 Cil Diesel	01/76 a 12/86	Com Polia	UB0325	7000153003	70992287
BMM0325	PERKINS	Perkins 4236 4 Cil Diesel	01/76 a 12/81	Com Polia	UB0325	7000153003	70992287
BMM0326	PERKINS	4236 4 Cil Diesel	01/76 a 12/81	Sem Polia	UB0326	7000152000	70991175X, 70992287X
BMM0326	PERKINS	4248 4 Cil Diesel	01/76 a 12/86	Sem Polia	UB0326	7000152000	70991175X, 70992287X
BMM0329	PERKINS	4203 4 Cil Diesel	01/66 a 12/76	Com Polia	UB0329	7000153001	70991412
BMM0330	PERKINS	4203 4 Cil Diesel	01/66 a 12/76	Sem Polia	UB0330	7000152001	70990329X
BMM0331	PERKINS	QB20B 4 Cil Diesel	01/84 a 12/92	Com Polia	UB0331	7000153006	70991456, 70992164, 70992165
BMM0332	PERKINS	QB20B 4 Cil Diesel	01/84 a 12/92	Sem Polia	UB0332	7000152002	70991456X, 70992164X, 70992165X, 70992165
BMM0553	PERKINS	6357 6 Cil Diesel	01/69 a 12/81	C/ polia simples de 5 1/2"	UB0553	7000153005	70990563, 70991409, P70991409A
BMM0554	PERKINS	6357 6 Cil Diesel	01/69 a 12/81	Sem Polia	UB0554	7000152004	70990553X, 70990563X, 70991409X, 7099168X, P70991409AX
BMM0558	PERKINS	6358 6 Cil Diesel	01/79	12/84	Sem polia	UB0558	7000152005 70991410, 70991452, 90991410
BMM0562	Rolo compactador Dynapac CP-27	QB20B - 6354 4/6 cil	Todos	Sem polia.	UB0562	7000152006	41313027, 6354141
BMM0562	Trator CBT 2500	QB20B - 6354 4/6 cil	Todos	Sem polia.	UB0562	7000152006	41313027, 6354141



Linha de produtos Magneti Marelli
Bomba d'água



CÓDIGO MAGNETI MARELLI	APLICAÇÃO	MOTOR		Obs.:	URBA	INDISA	CÓDIGO ORIGINAL
------------------------	-----------	-------	--	-------	------	--------	-----------------

PERKINS (cont.)

BMM0562	Trator CBT 8260 (4x4)	QB20B - 6354 4/6 cil	Todos	Sem polia.	UB0562	7000152006	41313027, 6354141
BMM0562	Trator Ideal CA1175 / CA 1175 DS (colheitadeira)	QB20B - 6354 4/6 cil	Todos	Sem polia.	UB0562	7000152006	41313027, 6354141
BMM0562	Trator Maxion MF 296 / 296.4CH - SH / 297/ 299	QB20B - 6354 4/6 cil	Todos	Sem polia.	UB0562	7000152006	41313027, 6354141
BMM0562	Trator Maxion MF 9110 / 9130 Turbo / 9150 / 9170	QB20B - 6354 4/6 cil	Todos	Sem polia.	UB0562	7000152006	41313027, 6354141
BMM0576	110	MWM D225 3 Cil Diesel	01/73 a 01/83		UB0576	7000104000	

SCANIA

BMM0576	110	MWM D225 4 Cil Diesel	01/73 a 01/83		UB0576	7000104000	
BMM0576	110	MWM D225 6 Cil Diesel	01/73 a 01/83		UB0576	7000104000	
BMM0982	110	DS11 6 Cil Diesel	01/75 a 12/76	C/ Filtro Dentro	UB0982	7000553000	259065
BMM5520	Caminhão P, R, T114GA 4x2, 6x4	NA/NZ 330, 360, 400, 420, 480, 1202 6cc			-	7000552000	1353072
BMM0984	K112	DS11 6 Cil DIESEL	01/83 a 12/93		UB0984	7000553001	524866
BMM0982	L111	DS11 6 Cil Diesel	01/75 a 12/76	C/ Filtro Dentro	UB0982	7000553000	259065
BMM0982	LS111	DS11 6 Cil Diesel	01/75 a 12/76	C/ Filtro Dentro	UB0982	7000553000	259065
BMM0982	LT111	DS11 6 Cil Diesel	01/75 a 12/76	C/ Filtro Dentro	UB0982	7000553000	259065
BMM5520	Ônibus Classe E	NA/NZ 330, 360, 400, 420, 480, 1202 6cc			-	7000552000	1353072
BMM5520	Ônibus Classe I 4x2, 6x2	NA/NZ 330, 360, 400, 420, 480, 1202 6cc			-	7000552000	1353072
BMM0324	P400	Perkins 4236 4 Cil Diesel	01/76 a 12/80	Com Polia	UB0324	7000153004	70992425
BMM0326	P400	Perkins 4236 4 Cil Diesel	01/76 a 12/80	Sem Polia	UB0326	7000152000	70991175X, 70992287X
BMM0984	S112	DS11 6 Cil DIESEL	01/83 a 12/93		UB0984	7000553001	524866
BMM0984	T112	DS11 6 Cil DIESEL	01/83 a 12/93		UB0984	7000553001	524866
BMM0576	62	MWM D225 3 Cil Diesel	01/73 a 01/83		UB0576	7000104000	

VALMET

BMM0576	62	MWM D225 4 Cil Diesel	01/73 a 01/83		UB0576	7000104000	
BMM0576	62	MWM D225 6 Cil Diesel	01/73 a 01/83		UB0576	7000104000	
BMM0576	65	MWM D225 3 Cil Diesel	01/73 a 01/83		UB0576	7000104000	
BMM0576	65	MWM D225 4 Cil Diesel	01/73 a 01/83		UB0576	7000104000	
BMM0576	65	MWM D225 6 Cil Diesel	01/73 a 01/83		UB0576	7000104000	
BMM0576	68	MWM D229 3 Cil Diesel	01/80 a 01/90		UB0576	7000104000	
BMM0576	68	MWM D229 4 Cil Diesel	01/80 a 01/90		UB0576	7000104000	
BMM0576	68	MWM D229 6 Cil Diesel	01/80 a 01/90		UB0576	7000104000	
BMM0576	85	MWM D225 3 Cil Diesel	01/73 a 01/83		UB0576	7000104000	
BMM0576	85	MWM D225 4 Cil Diesel	01/73 a 01/83		UB0576	7000104000	
BMM0576	85	MWM D225 6 Cil Diesel	01/73 a 01/83		UB0576	7000104000	
BMM0576	86	MWM D226 4 Cil Diesel	01/73 a 01/83		UB0576	7000104000	
BMM0576	88	MWM D229 3 Cil Diesel	01/80 a 01/90		UB0576	7000104000	
BMM0576	88	MWM D229 4 Cil Diesel	01/80 a 01/90		UB0576	7000104000	
BMM0576	88	MWM D229 6 Cil Diesel	01/80 a 01/90		UB0576	7000104000	
BMM0576	118	MWM D229 3 Cil Diesel	01/80 a 01/90		UB0576	7000104000	
BMM0576	118	MWM D229 4 Cil Diesel	01/80 a 01/90		UB0576	7000104000	
BMM0576	118	MWM D229 6 Cil Diesel	01/80 a 01/90		UB0576	7000104000	
BMM0576	138	MWM D229 3 Cil Diesel	01/80 a 01/90		UB0576	7000104000	
BMM0576	138	MWM D229 4 Cil Diesel	01/80 a 01/90		UB0576	7000104000	
BMM0576	138	MWM D229 6 Cil Diesel	01/80 a 01/90		UB0576	7000104000	
BMM0576	1780	MWM D229 3 Cil Diesel	01/80 a 01/90		UB0576	7000104000	
BMM0576	1780	MWM D229 4 Cil Diesel	01/80 a 01/90		UB0576	7000104000	
BMM0576	1780	MWM D229 6 Cil Diesel	01/80 a 01/90		UB0576	7000104000	



CÓDIGO MAGNETI MARELLI	APLICAÇÃO	MOTOR		Obs.:	URBA	INDISA	CÓDIGO ORIGINAL
------------------------	-----------	-------	---	-------	------	--------	-----------------

VALMET (cont.)

BMM0576	CF	MWM D229 3 Cil Diesel	01/80 a 01/90		UB0576	7000104000	
BMM0576	CF	MWM D229 4 Cil Diesel	01/80 a 01/90		UB0576	7000104000	
BMM0576	CF	MWM D229 6 Cil Diesel	01/80 a 01/90		UB0576	7000104000	
BMM0576	Empilhadeira	MWM D225 4 Cil Diesel	01/68 a 12/75		UB0576	7000104000	
BMM0576	Empilhadeira	MWM D229 3 Cil Diesel	01/80 a 01/90		UB0576	7000104000	
BMM0576	Empilhadeira	MWM D229 4 Cil Diesel	01/80 a 01/90		UB0576	7000104000	
BMM0576	Empilhadeira	MWM D229 6 Cil Diesel	01/80 a 01/90		UB0576	7000104000	
BMM0576	ID 110	MWM D225 3 Cil Diesel	01/73 a 12/83		UB0576	7000104000	
BMM0576	ID 110	MWM D225 4 Cil Diesel	01/73 a 12/83		UB0576	7000104000	
BMM0576	ID 110	MWM D225 6 Cil Diesel	01/73 a 12/83		UB0576	7000104000	
BMM0576	ID 62	MWM D225 3 Cil Diesel	01/73 a 12/83		UB0576	7000104000	
BMM0576	ID 62	MWM D225 4 Cil Diesel	01/73 a 12/83		UB0576	7000104000	
BMM0576	ID 62	MWM D225 6 Cil Diesel	01/73 a 12/83		UB0576	7000104000	
BMM0576	ID 65	MWM D225 3 Cil Diesel	01/73 a 12/83		UB0576	7000104000	
BMM0576	ID 65	MWM D225 4 Cil Diesel	01/73 a 12/83		UB0576	7000104000	
BMM0576	ID 65	MWM D225 6 Cil Diesel	01/73 a 12/83		UB0576	7000104000	
BMM0576	ID 85	MWM D225 3 Cil Diesel	01/73 a 12/83		UB0576	7000104000	
BMM0576	ID 85	MWM D225 4 Cil Diesel	01/73 a 12/83		UB0576	7000104000	
BMM0576	ID 85	MWM D225 6 Cil Diesel	01/73 a 12/83		UB0576	7000104000	
BMM0576	ID 86	MWM D226 4 Cil Diesel	01/73 a 12/83		UB0576	7000104000	
BMM0578	TA 985	MWM TD229 EC 4 Cil Diesel	01/80 a 12/90		UB0578	7000104001	
BMM0576	TF	MWM D225 3 Cil Diesel	01/73 a 12/83		UB0576	7000104000	
BMM0576	TF	MWM D225 4 Cil Diesel	01/73 a 12/83		UB0576	7000104000	
BMM0576	TF	MWM D225 6 Cil Diesel	01/73 a 12/83		UB0576	7000104000	
BMM0576	TM 78	MWM D229 4 Cil Diesel	01/80 a 12/90		UB0576	7000104000	
BMM0576	TM 88	MWM D229 4 Cil Diesel	01/80 a 12/90		UB0576	7000104000	
BMM0576	TM 880	MWM D229 4 Cil Diesel	01/80 a 12/90		UB0576	7000104000	
BMM0576	TM 885	MWM D229 4 Cil Diesel	01/80 a 12/90		UB0576	7000104000	
BMM0576	TS 78	MWM D229 4 Cil Diesel	01/80 a 12/90		UB0576	7000104000	
BMM0576	TS 88	MWM D229 4 Cil Diesel	01/80 a 12/90		UB0576	7000104000	
BMM0578	TS 980	MWM TD229 4 Cil Diesel	01/80 a 12/90		UB0578	7000104001	
BMM0576	TS 985	MWM TD229 4 Cil Diesel	01/80 a 12/90		UB0576	7000104000	
BMM0576	TV 118	MWM D229 6 Cil Diesel	01/80 a 12/90		UB0576	7000104000	
BMM0576	TV 138	MWM TD229 6 Cil Diesel	01/80 a 12/90		UB0576	7000104000	
BMM0576	TV 68	MWM D229 3 Cil Diesel	01/80 a 12/90		UB0576	7000104000	
BMM0576	TV 78	MWM D229 4 Cil Diesel	01/80 a 12/90		UB0576	7000104000	
BMM0576	TV 88	MWM D229 4 Cil Diesel	01/80 a 12/90		UB0576	7000104000	
BMM0578	VA 1580	MWM TD229 EC 6 Cil Diesel	01/80 a 12/90		UB0578	7000104001	
BMM0578	VA 1780	MWM TD229 EC 6 Cil Diesel	01/80 a 12/90		UB0578	7000104001	
BMM0576	VB 685	MWM D229 3 Cil Diesel	01/80 a 12/90		UB0576	7000104000	
BMM0576	VE 78	MWM D229 4 Cil Diesel	01/80 a 12/90		UB0576	7000104000	
BMM0576	VE 88	MWM D229 4 Cil Diesel	01/80 a 12/90		UB0576	7000104000	
BMM0578	VM 128	MWM D229 6 Cil Diesel	01/80 a 12/90		UB0578	7000104001	
BMM0578	VM 1280	MWM D229 6 Cil Diesel	01/80 a 12/90		UB0578	7000104001	
BMM0578	VM 1580	MWM TD229 EC 6 Cil Diesel	01/80 a 12/90		UB0578	7000104001	
BMM0578	VM 1780	MWM TD229 EC 6 Cil Diesel	01/80 a 12/90		UB0578	7000104001	
BMM0576	VM 68	MWM D229 3 Cil Diesel	01/80 a 12/90		UB0576	7000104000	
BMM0576	VM 685	MWM D229 3 Cil Diesel	01/80 a 12/90		UB0576	7000104000	
BMM0576	VM 78	MWM D229 4 Cil Diesel	01/80 a 12/90		UB0576	7000104000	
BMM0576	VM 88	MWM D229 4 Cil Diesel	01/80 a 12/90		UB0576	7000104000	
BMM0576	VM 985	MWM TD229 EC 4 Cil Diesel	01/80 a 12/90		UB0576	7000104000	
BMM0576	VO 78	MWM D229 4 Cil Diesel	01/80 a 12/90		UB0576	7000104000	
BMM0576	VO 88	MWM D229 4 Cil Diesel	01/80 a 12/90		UB0576	7000104000	
BMM0576	VP 78	MWM D229 4 Cil Diesel	01/80 a 12/90		UB0576	7000104000	
BMM0576	VP 88	MWM D229 4 Cil Diesel	01/80 a 12/90		UB0576	7000104000	



Linha de produtos Magneti Marelli Bomba d'água



CÓDIGO MAGNETI MARELLI	APLICAÇÃO	MOTOR		Obs.:	URBA	INDISA	CÓDIGO ORIGINAL
VALMET (cont.)							
BMM0578	VR 128	MWM D229 6 Cil Diesel	01/80 a 12/90		UB0578	7000104001	
BMM0576	VR 148	MWM TD229 6 Cil Diesel	01/80 a 12/90		UB0576	7000104000	
BMM0576	VR 78	MWM D229 4 Cil Diesel	01/80 a 12/90		UB0576	7000104000	
BMM0576	VR 88	MWM D229 4 Cil Diesel	01/80 a 12/90		UB0576	7000104000	
BMM0576	VR 985	MWM TD229 4 Cil Diesel	01/80 a 12/90		UB0576	7000104000	
BMM0576	VS 128	MWM D229 6 Cil Diesel	01/80 a 12/90		UB0576	7000104000	
BMM0576	VS 138	MWM TD229 6 Cil Diesel	01/80 a 12/90		UB0576	7000104000	
BMM0576	VS 148	MWM TD229 6 Cil Diesel	01/80 a 12/90		UB0576	7000104000	
BMM0576	VS 685	MWM D229 3 Cil Diesel	01/80 a 12/90		UB0576	7000104000	
BMM0576	VS 78	MWM D229 4 Cil Diesel	01/80 a 12/90		UB0576	7000104000	
BMM0576	VS 88	MWM D229 4 Cil Diesel	01/80 a 12/90		UB0576	7000104000	
BMM8000	Trator BF65				-	7000800000	836764215K
BMM8000	Trator BF75				-	7000800000	836764215K
BMM8000	Trator BL77				-	7000800000	836764215K
BMM8000	Trator BL88				-	7000800000	836764215K
BMM8000	Trator BM100				-	7000800000	836764215K
BMM8000	Trator BM110				-	7000800000	836764215K
BMM8000	Trator BM600				-	7000800000	836764215K
BMM8000	Trator BM700				-	7000800000	836764215K
BMM8000	Trator BM800				-	7000800000	836764215K
BMM8000	Trator BM85				-	7000800000	836764215K
BMM8000	Trator BM900				-	7000800000	836764215K
VOLKSWAGEN							
BMM0576	11-130	MWM D229 6 Cil Diesel	01/80 a 12/90		UB0576	7000104000	2RB121005, 922987310026, 922507310015
BMM0576	11-140	MWM D229 6 Cil Diesel	01/80 a 12/90		UB0576	7000104000	2RB121005, 922987310026, 922507310015
BMM0576	12-140	MWM D229 6 Cil Diesel	01/82 a 12/06		UB0576	7000104000	2RB121005, 922987310026, 922507310015
BMM0576	13-130	MWM D229 6 Cil Diesel	01/80 a 12/90		UB0576	7000104000	2RB121005, 922987310026, 922507310015
BMM0579	14-150	MWM série 10 Aspirado 6 Cil Diesel	01/80 a 12/90		UB0579	7000105001	
BMM0579	14-200	MWM série 10 Turbo 6 Cil Diesel	01/80 a 12/90		UB0579	7000105001	
BMM0732	14-220	Cummins 6CT 8.3 Diesel	01/80 a 12/90		UB0732	7000452000	3802081, 3913430
BMM0731	16-170	Cummins 6BT-5.9 6 Cil Diesel	01/76 a 11/86		UB0731	7000452002	3802358, 3802970, BF5X/8501/A
BMM0731	16-170	Cummins 6BTA-5.9 6 Cil Diesel	01/76 a 11/86		UB0731	7000452002	3802358, 3802970, BF5X/8501/A
BMM0731	16-170	Cummins 6BTAA-5.9 6 Cil Diesel	01/76 a 11/86		UB0731	7000452002	3802358, 3802970, BF5X/8501/A
BMM0579	16-180CO	MWM série 10 Turbo 6 Cil Diesel	01/80 a 12/90		UB0579	7000105001	
BMM0732	24-220	Cummins 6CT 8.3 Diesel	01/80 a 12/90		UB0732	7000452000	3802081, 3913430
BMM0732	24-250	Cummins 6CTAA 8.3 Diesel	01/80 a 12/90		UB0732	7000452000	3802081, 3913430
BMM0732	35-300	Cummins 6CTAA 8.3 Diesel	01/80 a 12/90		UB0732	7000452000	3802081, 3913430
BMM0324	6-80	Perkins 4236 4 Cil Diesel	01/82 a 12/85	Com Polia	UB0324	7000153004	70992425
BMM0326	6-80	Perkins 4236 4 Cil Diesel	01/82 a 12/85	Sem Polia	UB0326	7000152000	70991175X, 70992287X
BMM0576	6-90	MWM D229 4 Cil Diesel	01/80 a 12/90		UB0576	7000104000	2RB121005, 922987310026, 922507310015
BMM0579	7-100	MWM série 10 Aspirado 4 Cil Diesel	01/92 a 12/02		UB0579	7000105001	



CÓDIGO MAGNETI MARELLI	APLICAÇÃO	MOTOR		Obs.:	URBA	INDISA	CÓDIGO ORIGINAL
VOLKSWAGEN (cont.)							
BMM0578	7-110 CO	MWM TD229 EC 4 Cil Diesel	01/80 a 12/90		UB0578	7000104001	
BMM0576	7-90 CO	MWM D229 4 Cil Diesel	01/80 a 12/90		UB0576	7000104000	2RB121005, 922987310026, 922507310015
BMM0579	8-140	MWM série 10 Turbo 4 Cil Diesel	01/80 a 12/90		UB0579	7000105001	
BMM0054	51C-050	Ford BF 161 6 Cil Diesel	01/60 a 12/72		UB0054	7000204002	643564 e BD4B8501A
BMM0054	51P-030	Ford BF 161 6 Cil Diesel	01/60 a 12/72		UB0054	7000204002	643564 e BD4B8501A
BMM0054	51P-040	Ford BF 161 6 Cil Diesel	01/60 a 12/72		UB0054	7000204002	643564 e BD4B8501A
BMM0054	51P-050	Ford BF 161 6 Cil Diesel	01/60 a 12/72		UB0054	7000204002	643564 e BD4B8501A
BMM0135	83P-060	GM 250 6 Cil Diesel	01/69 a 12/92		UB0135	7000254000	7330495, 7322682
BMM0135	83P-080	GM 250 6 Cil Diesel	01/69 a 12/92		UB0135	7000254000	7330495, 7322682
BMM0135	83P-100	GM 250 6 Cil Diesel	01/69 a 12/92		UB0135	7000254000	7330495, 7322682

linha de
produtos

MAGNET
MARET

bomba d'água e
óleo premium,
compressor



Linha de produtos Magneti Marelli
Bomba d'água, óleo premium
e compressor



Linha de produtos Magneti Marelli - Bomba d'água premium

APLICAÇÃO/ DESCRIÇÃO	Nº ORIGINAL	MAGNETI MARELLI	URBA	SCHADEK
IVECO				
IVECO CURSOR 13	500356553 504276057 99483937	BMMP0892	-	-
SCANIA				
Caminhões P/R/T 114 / R/T 124 (05/...) Ônibus Classe E - DSC 1202 / 1205 - Classe I - K 124 Para motores NA/NZ - 330 / 360 / 400 / 420 / DSC 1202 / DSC 1205 Série 4 - 6 cil. / For NA/NZ - 330 / 360 / 400 / 420 / DSC 1202 / DSC 1205 Série 4 - Com tampa traseira	1.787.120 1.789.522	BMMP0890	-	20195-A
Caminhões P/R/T 114 / R/T 124 (05/...) Ônibus Classe E - DSC 1202 / 1205 - Classe I - K 124 Para motores NA/NZ - 330 / 360 / 400 / 420 / DSC 1202 / DSC 1205 Série 4 - 6 cil. / For NA/NZ - 330 / 360 / 400 / 420 / DSC 1202 / DSC 1205 Série 4 - Sem tampa traseira	1.787.120	BMMP0891	UB0981	20195

Linha de produtos Magneti Marelli - Bomba de óleo premium

APLICAÇÃO/ DESCRIÇÃO	Nº ORIGINAL	MAGNETI MARELLI	SCHADEK
IVECO			
Eurostar LD 440 / Eurotrakker MP 190 E / Eurotrakker MP 260 E Eurotrakker MP 340 E / Eurotrakker MP 380 E / Eurotrakker MP 410 E Stralis AS 260 S 48 / Stralis AS 260 S 54 / Stralis AS 440 S 48/ Stralis AS 440 S 54 / Trakker AD 190 T 38W / AT 190 T 38W / Trakker AD 190 T 44W / AT 190 T 44W Trakker AD 260 T 38 / AT 260 T 38 Polia com 12 dentes	504374587 504128373 99452340	BMMOP10505	-
MWM			
Motores: 4.12TCE -150 a 206 cv - 4,8 litros 4 cil./6.12TCE - 210 a 310 cv - 7,2 litros 6 cil. Volare: W8 / W9 / A8 Agrale:8500/ 8500D/ 9200/ 9200D/ Chassi MA 7.5/ MA 8.5/ MA 9.2 VW: 13.170E/ 13.180E/ 14.180E OD/ 15.170E/ 15.180E/ 15.180EOD / 15.190E/ 8.150EOD/ 9.150EOD/ 17.210E/ 23.210E/ 17.210EOD/17.260EOD/ 17.260EOT/ 18.320E/ 26.260E/ 26.260E/ 31.260E(6X4) Volvo: VM 210/ VM 260/ VM 310 Corpo em ferro / Com engrenagem de 0º / With 0º gear	9.612.0.730.001.6 9.612.0.730.003.6 VW: 2R0/115105-C 2R0/115105-A	BMMOP10241	10241

Linha de produtos Magneti Marelli - Compressor

MAGNETI MARELLI	APLICAÇÃO/ DESCRIÇÃO	CÓDIGO OE
IVECO		
8FK351108961	Compressor - IVECO STRALIS / EUROESTAR 06 - SE10B17 110MM 24V POLY V4	99488569
SCANIA		
8FK351134821	Compressor - Compressor - SCANIA 124/T114/T124/114 SE7H15 123MM 24V POLY V8 95-98	
VOLVO		
8FK351132671	Compressor - Volvo SE7H15 132MM 24V POLY V8	

linha de
produtos

MAGNET

correia automática

caminhões, ônibus, máquinas e
implementos agrícolas



Linha de produtos Magneti Marelli
Correia automotiva para caminhões



MODELO	MOTOR	ANO	APLICAÇÃO	TIPO CORREIA	CÓDIGO
--------	-------	-----	-----------	--------------	--------

AGRALE

8500	MWM 4.10T 4 CILS.	todos	GIR / ALT / BA (C/ALT 14 V 55A)	multi V	8MM1400
4500 / RS / RSD / 5000 / RS / 7000	TODOS	todos	GIR / ALT / BA	V	MMX13X1250
6000 / 6000 CD	MWM SPRINT 4.07 TCA 4 CILINDROS	todos	GIR / ALT / BA	multi V	6MM894
7000D / RD	MWM 4.10T 4 CILS.	todos	GIR / ALT / BA (C/ALT 14 V 55A)	multi V	8MM1400
7500 TDX	MWM 4.10T 4 CILS.	todos	GIR / ALT / BA (C/ALT 14 V 55A)	multi V	8MM1400
ULTRAVAN RD	MAXION 5.4	todos	GIR / ALT / BA	V	MMX13X1275

FIAT

130 F 15		75/...	GIR / ALT / BA	V	MMX13X1260
190 F / 190 H		75/85	GIR / ALT / BA	V	MMX10X1025
190 F / 190 H		75/85	GIR / PLI / BA	V	MMX13X1425

FORD

C-1215 / 1415 / 1617	CUMMINS 6BT 5.9	95/...	GIR / ALT / BA / DH	multi V	8MM1435
C-2422 / 2425 / 2630	CUMMINS 6BT 8.3	95/...	GIR / ALT / BA / DH	multi V	8MM1600
CARGO - 1422 / 1622 / 2322 / 3224 / 3530 / 4030	CUMMINS 6CTAA 8.3L	95/...	GIR / ALT / BA / DH	multi V	8MM1420
CARGO (C / ACD) 1113 / 1114 / 1117 / 1313 / 1314 / 1317 / 1514 / 1517	FORD	85/...	GIR / PLI / ACD	V	MMX13X1600
CARGO 1113 / 1114 / 1117 / 1313 / 1314 / 1317 / 1514 / 1517	FORD	85/...	GIR / ALT / BA		MMX13X1450
CARGO 1215 / 1217 / 1415 / 1417 / 1421 / 1617 / 1621 / 2322 / F12000 / F14000 / F16000	CUMMINS 6BTAA 5.9L	95/...	GIR / ALT / BA / DH	multi V	8MM1445
CARGO TODOS	FORD	85/94	GIR / DH	V	MMX13X1025
F-1000 / F-2000 / F-4000	MWM 229.4 / 229.6	96/...	GIR / ALT / BA / DH / S/ACD	multi V	8MM1376
F-11000 / 12000 / 13000	PERKINS	80/...	GIR / ALT / BA	V	MMX13X1300
F-11000 / 12000 / 13000	PERKINS 6 CILS.	80/...	GIR / DH		MMX13X900
F-12000 / 13000 / 14000 / 21000	MWM 6 CILS.	80/...	GIR / DH	V	MMX10X1238
F-12000 / 13000 / 19000 / 21000	MWM 6 CILS.	80/89	GIR / ALT / BA	V	MMX13X1350
F-12000 / 14000	MWM 229 6 CILS.	93/...	GIR / ALT / BA	V	MMX13X1200
F-12000 / 14000 (C/DH)	MWM 6CILS.	93/...	GIR / DH	V	MMX13X1300
F-12000 / F-14000 / F-16000	MWM 229.6	90/95	GIR / ALT / BA	V	MMX13X1188
F-14000	MWM 4.10T	96/...	GIR / ALT / BA / DH	multi V	8MM1435
F2000	FORD 4.9 I	94/...	GIR / ALT / BA / DH / ACD	multi V	6MM2063
F2000	MAXION HSD	96/...	GIR / ALT / BA / DH C/ OU S/ ACD	multi V	7MM1530
F-2000 / F-4000	MWM 229.4 / 229.6	96/...	GIR / ALT / BA / DH S/ACD	multi V	8MM1376
F-250 / F-350 / F-4000	CUMMINS 4BTAA/4BTAA 3.9L	98/...	GIR / ALT / BA / DH / ACD	multi V	8MM2063
F-350	CUMMINS 4BTAA 3.9L	98/...	GIR / ALT / BA / DH	multi V	8MM1420
F-4000	FORD	84/87	DH	V	MMX13X1075
F-4000	CUMMINS 4BTAA 3.9L	96/set 98	GIR / ALT / BA / DH	multi V	8MM1420
F-4000	FORD	84/87	GIR / DH	V	MMX13X1060
F-4000	MWM 229.4	93/95	GIR / DH	V	MMX13X938
F-600 / F-700 / F-750 (DIESEL)	PERKINS 6 CILS.	68/...	GIR / ALT / BA	V	MMX13X1300

GENERAL MOTORS

12-170 / 14-190 / 16-220	CATERPILLAR 3116 6 CIL.	96/...	GIR / ALT / DH	multi V	7MM1795
15-190	CATERPILLAR 3116 6 CIL.	96/...	GIR / ALT / DH	multi V	7MM1400
15-90 (CAMINHÃO)	CATERPILLAR 3116 6 CIL.	96	GIR / ALT / DH	multi V	7MM1400
3500HD	MWM SPRINT 6.07 T 4.2L	00/...	GIR / ALT / BA / DH	multi V	6MM1250
3500HD	MWM SPRINT 6.07T 4.2L	00/...	GIR / ALT / BA / DH / ACD	multi V	6MM1885
5-90	ISUZU 4JG2 3.1L	98/...	GIR / ALT / BA / DH	V	MMX17X1040
6-100	MAXION S4 4 CILS.	96	GIR / ALT / BA	V	MMX10X1175
6150 (C/ACD)	MWM 6.07 THD 4.2L	96/...	GIR / ALT / BA / DH	multi V	6MM1885
7-110	MWM 4HF1 4.1L	96/...	GIR / ALT / VT	V	MMX13X1050
A/ C/ 40/ 6 / 70/ 80/ 90		85/...	GIR / BA / CPA / DH	V	MMX13X1260
A/ C/ 60/ 70/ 80/ 90 (FREIO A AR)		85/...	GIR / VT / CPA	V	MMX13X1260

ACD - ar condicionado
ALT - alternador
BA - bomba d'água
BH - bomba hidráulica
BHP - bomba hidr. princ.
CP - comp.

VT - ventilador
CVA - comando de válvula
DH - direção hidráulica
GIR - virabrequim
PLI - polia intermediária
CPA - compressor de ar

(2) Conj. 2 Correias
(3) Conj. 3 Correias



MODELO	MOTOR	ANO	APLICAÇÃO	TIPO CORREIA	CÓDIGO
--------	-------	-----	-----------	--------------	--------

GENERAL MOTORS (cont.)

D-60 / 70 / 80 / 90	PERKINS	70/84	GIR / ALT / VT	V	MMX13X1285
D-60 / 70 / 80 / 90 (C/DH)		81/...	GIR / BA / CPA / DH	V	MMX13X1175
D-60 / 70 / 80 / 90 (S/DH)		81/...	GIR / ALT / BA	V	MMX13X1000
D-60 / 70 / 80 / 90 / 11000	PERKINS	90/93	GIR / ALT / BA	V	MMX13X1350
GMC 6100 / 6150 / 6000 / 6000 TURBO (C/DH)	4.1 MAXION	96/...	GIR / ALT / BA / DH	V	MMX13X1275

INTERNATIONAL

4700	INTERNATIONAL DT466E 6 CIL.	todos	GIR / ALT / BA / DH	multi V	8MM1813
4900 16T / 4900 24T	INTERNATIONAL DT466E 6 CIL.	todos	GIR / ALT / BA / DH	multi V	8MM1840
9200 16T / 9200 24T	CUMMINS ISM 380 / ISM 405E 6 CIL.	todos	ACD	V	MMX17X1250

IVECO

DAILY 35.10 / 49.12	2.8 TURBO DIESEL	97/00	GIR / ALT / BA / S/ACD	V	MMX10X940
DAILY 35.10 / 49.12	2.8 TURBO DIESEL	97/00	DH	V	MMX13X890
DAILY 35.10 / 49.12	35.10 IVECO 8140.23	todos	ACD NÃO ORIGINAL DUPLO AR	multi V	6MM1390
EUROTECH	450E37 IVECO 8210.42K	98/...	ALT	V	MMX13X1050
EUROTRAKKER	450E37 IVECO 8210.42K	98/...	ALT	V	MMX13X1050
MA 7.5T (C/ALT. 55AH)	MWM 4.10T 4 CILS.	todos	GIR / ALT / BA / DH	multi V	8MM1400

MERCEDES-BENZ

K 1720	OM366-A / LA 6 CILINDROS	todos	GIR / ALT / BA	V	MMX13X1350
S 1723	OM366-A / LA 6 CILINDROS	todos	GIR / ALT / BA	V	MMX13X1350
1618	366 TURBINADO		GIR / ALT / BA	V	MMX13X1338
1721	MBB - OM 366-A		GIR / ALT / BA	V	MMX13X1300
1111/ 1113/ L-LA/ K/ S-LK-LS 1114/ 1313/ 1314/ 1316/ 1513/	MBB - OM 352		GIR / ALT / BA	V	MMX13X1475
1214/ 1614/ 1714/ 2314	MBB - OM 366		GIR / ALT	V	MMX13X1350
1215/ 1315/ 1316/ 1320/ 1420	OM-366 / 366A	todos	GIR / PLI	V	MMX13X1700
1217/ 1318/ 1418R/ K 1720/ S 1723	OM366 / OM366-A / LA 6 CILINDROS	todos	GIR / ALT / BA / DH	V	MMX13X1025
1217/OF/ 1318/OF/ 1414/ 1517/LP/ 1614/ 1620/OF/ 1621/ 1718/OF/ 1721/OF/ 2314/ 2318/L-LA-LK/ 2420/LK	OM366 A 6CIL / OM366-A / LA 6 CIL	todos	DH	V	MMX13X920/925
1218 / 1414 / 1418 / 1618 / 1620 / 1621 / 1718 / 1721	MBB - OM 366-L / LA / S		GIR / ALT / BA	V	MMX13X1350
1218 / 1418 / 1517 / 1718	MBB - OM 366-A		GIR / ALT / BA	V	MMX13X1350
1513 / L-LA-LK-LS-LAK-LAS / 2013 / L-LA-LK-LS-LAK-LAS	OM352	todos	BA / DH	V	MMX13X900
1514 / 1516 / 2013 / 2014 / 2213 / 2216 / L-LB 1518 / 2017				V	MMX13X1475
1519 / 1924 / 1924A / 1929 / 1932 / 2019 / 2219 / 2224 / 2419/	MBB - OM 355 / 5 E 6 CILS.		GIR / CPA / BA	V	MMX13X1750
1620	-	todos	ALT	V dupla	2XMMX13X1375
1630 / 1929	MBB - OM 449-LA		GIR / ALT / BA	V	MMX13X1575
1718M	904 LA	todos	GIR / ALT / BA	multi V	8MM1420
1721/OF	OM366 A 6CIL.	99/...	GIR / ALT / BA	V dupla	2XMMX13X1375
1929	OM449-LA	todos	ALT / ACD	V dupla	2XMMX13X1150
1938 ELETRÔNICO (S/ACD) - VENTUINHA	MBB-OM 457-LA NO. ORIG. 0149976692		GIR / ALT	multi V	8MM1600
2214 L / LA / LK / LS	MBB - OM 352		GIR / BA / DH	V	MMX13X875
2216/ 17/ LB2216/ 17/ L-LK1118/ 13171318 L-LK-LS 1517 / 1518	MBB - OM 352-A		GIR / BA / DH	V	MMX13X875
2220 / 2224 / 2419 / 2432 / 2624 C/ INJ.DIRETA	MBB - OM 355 / 5 E 6 CILS.		GIR / ALT	V	MMX13X1150
2325 / 1625	MBB - OM 449-A		GIR / ALT / BA	V	MMX13X1575
2423B / 2423K	OM-906 LA 4 CILS.	todos	GIR / ALT / BA	multi V	8MM1420
2432 / 2624 C/INJ.DIRETA	MBB - OM 355 / 5 E 6 CILS.		GIR / CPA / BA	V	MMX13X1750
2638 L-LS-LK	OM 457-LA		GIR / ALT / BA	multi V	8MM1600

ACD - ar condicionado
ALT - alternador
BA - bomba d'água
BH - bomba hidráulica
BHP - bomba hidr. princ.
CP - comp.

VT - ventilador
CVA - comando de válvula
DH - direção hidráulica
GIR - virabrequim
PLI - polia intermediária
CPA - compressor de ar

(2) Conj. 2 Correias
(3) Conj. 3 Correias



Linha de produtos Magneti Marelli
Correia automotiva para caminhões



MODELO	MOTOR	ANO	APLICAÇÃO	TIPO CORREIA	CÓDIGO
--------	-------	-----	-----------	--------------	--------

MERCEDES-BENZ (cont.)

608D / 708D / 708E	OM314	todos	GIR / ALT / BA	V	MMX13X1275
709/L / 812/OF	OM364-A 4 CIL	todos	BA / DH	V	MMX13X920/925
710 / L-LA-LK 709 / 1214 / 1215 / 1621 / 2420 / OF-712 / 812 / 912 OH-1317 / 1318 / 1319 / 1320	OM364-A / LA 4 CILINDROS	todos	GIR / ALT / BA	V	MMX13X1300
712C / 914C	OM-904-LA NO. ORIG. 906.997.0792	98/...	GIR / ALT / BA	multi V	8MM1480
712C / 914C / 1215C	OM-904 LA 4 CILS.	todos	GIR / ALT / BA	multi V	8MM1420
C180	1.8 16V	93/96	GIR / ALT / BA / DH / ACD	multi V	6MM2145
C180 / C200	1.8 16V / 2.0 16V	96/...	GIR / ALT / BA / DH / ACD	multi V	6MM2155
C200	2.0 16V	93/96	GIR / ALT / BA / DH / ACD	multi V	6MM2145
C280	2.8	93/01	GIR / ALT C / ACD	multi V	6MM2145
CAMINHÕES ELETRÔNICOS	OM-904/906 LA	98/...	GIR / ALT / BA	multi V	8MM1230
CAMINHÕES ELETRÔNICOS	OM-906-LA NO. ORIG. 906.997.2892	98/...	GIR / ALT / BA	multi V	8MM1905
ELETRÔNICO	OM-904/906 LA	98/...	ALT	multi V	8MM2063
ELETRÔNICO	OM-906-LA	98/...	ALT	multi V	8MM1988
L / LK 1214 / L 1618 / 2418	MBB - OM 366-A / LA		GIR / ALT / BA	V	MMX13X1375
L / LK-LS 1116 / 1316 / 1318 /	MBB - OM 352-A		GIR / ALT / BA	V	MMX13X1475
L / LS / LB / LK 1519 / 1520 / 1924A/ 1929 / 1932 / 2019 / 2219	MBB - OM 355 / 5 E 6 CILS.		GIR / ALT	V	MMX13X1150
L / LS / LK1218 / 1414 / 1418 / 1618 / 1620 / 1621 / 1718 / 1721	MBB - OM 366-L/LA		GIR / DH	V	MMX13X1025
L / LS 1935 / 1938 / 1941	MBB - OM 447-LA		GIR / CPA / BA	V	MMX13X1575
L / LS-LK1935/ 1938/ 1941/ 1945 (TOP BRAKE)	MBB-OM 447-LA		GIR / ALT / BA / VT	V	MMX13X1575
L / LS-LK2325 / 2635	MBB-OM 449-A 5 CILS.		GIR / ALT / BA / VT	V	MMX13X1575
L 1218 / L-LK 1621 / 2420 / L-LA-LK 1418 / 1618 / 1720 / 2318	MBB - OM 366-A / LA		GIR / ALT / BA	V	MMX13X1300
L 608 / L 708	MBB - OM 314		GIR / ALT / BA	V	MMX13X1260
L 709 / 912	MBB - OM 364-A		GIR / ALT / BA	V	MMX13X1300
L 709 / L710 / L 912	MBB - OM 364		GIR / BA / DH	V	MMX13X968
L 709 / L914	MBB - OM 364-A		GIR / BA / DH	V	MMX13X950
L 709 / OF 812	OM364-A 4 CILINDROS	todos	BA / DH	V	MMX13X925
L 914 (C/DH)	MBB - OM 364-A		GIR / ALT / BA	V	MMX13X1275
L / LK 1214 / 1215 / 1414 / 1614 / 1714 / 1715 / 2314	MBB - OM 366		GIR / ALT / BA	V	MMX13X1325
L / LA / LK 1214 / 1215 / 1414 / 1418 / 1614 / 1618 / 1621 / 1720 / 2314 / 2318 / 2420	MBB - OM 366-A		GIR / DH	V	MMX13X925
L1622	924 LA	todos	GIR / ALT / BA	multi V	8MM1420
L914	MBB - OM 364-A		GIR / DH	V	MMX13X925
LP 1517 / OF 1217 / 1318 / 1620 / 1718 / 1721	MBB - OM 366-A		GIR / DH	V	MMX13X925
MB180	OM616	todos	GIR / DH	V	MMX13X685
SPRINTER / FURGÃO 312D/35.5 - 412D / 35.5 E 40.25 - 312D / 30 E 35.5	OM-014 LA 4CIL 2.5L	01/...	GIR / ALT / BA	multi V	6MM2265
SPRINTER / FURGÃO 312D/ 35.5 - 412D / 35.5 E 40.25 - 312D / 30 E 35.5	OM-014 LA 4CIL 2.5L	01/...	GIR / ALT / BA / ACD	multi V	6MM2272
114 - 124	DSC-1101 / DSC-1201	98/...	ALT / ACD	multi V	8MM1988
114 (C/ACD)	NO. ORIG. 1371533 / 1389042	98/...	GIR / ALT / ACD	multi V	8MM2163

SCANIA

B-110L / LS / LT 101 / 110	SCANIA	71/78	GIR / ALT / BA / PLI	V	MMX13X1600
K-112 / L-113	TODOS	84/...	GIR / ALT / BA	V	MMX13X1863
K-124	C/ 01 ALT.	98/...	GIR / ALT / BA	multi V	8MM1509
K-124	COM 2 ALTERNADORES	98/...	GIR / ALT / BA	multi V	8MM2063
K-124	DSC 1205	98/...	GIR / ALT / BA C/2 ALT	multi V	8MM2063
L / LK 140 / 141			GIR / ALT / BA	V	MMX13X1325
L / LS / LT 111 1ªSÉRIE		71/78	GIR / ALT / BA	V	MMX13X1575
L/LS/LT 111 2ªSÉRIE		78/...	GIR / ALT / BA	V	MMX13X1625

ACD - ar condicionado
ALT - alternador
BA - bomba d'água
BH - bomba hidráulica
BHP - bomba hidr. princ.
CP - comp.

VT - ventilador
CVA - comando de válvula
DH - direção hidráulica
GIR - virabrequim
PLI - polia intermediária
CPA - compressor de ar

(2) Conj. 2 Correias
(3) Conj. 3 Correias



MODELO	MOTOR	ANO	APLICAÇÃO	TIPO CORREIA	CÓDIGO
--------	-------	-----	-----------	--------------	--------

SCANIA (cont.)

P-114 6A	DSC 1107	todos	GIR / ALT / BA / DH / S/ACD	multi V	8MM2063
P-114 6A	DSC-1107	98/...	GIR / ALT / BA / DH S/ACD	multi V	8MM2063
P-114 CA 6X4 NZ (S/ACD)	DSC11 6 CILS.	todos	GIR / ALT / BA / DH	multi V	8MM1509
P-124	NZ 420	todos	GIR / ALT / BA / DH	multi V	8MM1509
P-124 6A	NZ 360	todos	GIR / ALT / BA / DH	multi V	8MM1509
P-124 CA 6X4 NZ (S/ACD)	DSC12 6 CILS.	todos	GIR / ALT / BA / DH	multi V	8MM1509
P124-6A	DSC-1202	todos	GIR / ALT / BA / DH / ACD	multi V	8MM2063
P124-6A	DSC-1205	todos	GIR / ALT / BA / DH / ACD	multi V	8MM2063
R / T - 114 GB 4X2 NZ	DSC1107	todos	GIR / ALT / BA / DH S / ACD	multi V	8MM2115
R / T-124 LA 4X2 NA / 6X4 NZ / 6X2 NA	DSC-1202	todos	GIR / ALT / BA / DH C / ACD	multi V	8MM1980
R/T-114GB 4 X 2 NZ	DCS-1107	todos	GIR / ALT / BA / DH / S/ACD	multi V	8MM2063
R/T-124LA 4 X 2 NA / R/T-124LA 6 X 4 NZ / R-124LA 6 X 2 NA	DSC 12 6CIL	todos	GIR / ALT / BA / DH	multi V	8MM1550
R/T-124LA 4 X 2 NA / R/T-124LA 6 X 4 NZ / R-124LA 6 X 2 NA	DSC-1202	todos	GIR / ALT / BA / DH S/ACD	multi V	8MM1538
R-114 / T-114 / T-124	DSC-1107/ DSC-1202/ DSC-1201/ DSC-1205	todos	GIR / ALT / BA / DH S/ACD	multi V	8MM1580
R-124	DSC-1205	todos	GIR / ALT / BA / DH / ACD	multi V	8MM1980
R-124 / T-124	DSC-1201	todos	GIR / ALT / BA / DH / ACD	multi V	8MM1980
R-124 / T-124	DSC-1201 / DSC-1205	todos	GIR / ALT / BA / DH S/ACD	multi V	8MM1538
S-112		81/...	GIR / ALT / BA	V	MMX13X1625
S-112A (C/ALT 105AH)	SCANIA	83/...	GIR / ALT / BA	V	MMX13X1750
T-112 / R-112HS	(ALT EMBAIXO)	82/89	GIR / ALT / BA	V	MMX13X1575
T-112H / HW / T-113H (C/ACD)		novos	GIR / ALT / BA	V	MMX13X1575
T-112H / HW R-112H / HW		81/...	GIR / ALT / BA	V	MMX13X1625
T-112HS / R-112HS	(ALT EM CIMA)	82/89	GIR / ALT / BA	V	MMX13X1600
T-112HW		90/97	GIR / ALT / BA	V	MMX13X1550
T-113		90/97	GIR / ALT / BA	V	MMX13X1550
T-113H / R-113H		94/...	GIR / ALT / VT	V	MMX13X1550
T-124	DSC-1202	todos	GIR / ALT / BA / DH / S/ACD	multi V	8MM2063
T-124	NZ 360	todos	GIR / ALT / BA / DH / ACD	multi V	8MM1509
T-142 / R-142H / HW (C/ACD)	SCANIA	81/...	GIR / ALT / BA	V	MMX13X1425
T-142 / R-142H / HW (S/ACD)	SCANIA	81/...	GIR / ALT / BA	V	MMX13X1225
T-143H / R-143H		94/...	GIR / ALT / VT	V	MMX13X1225
680	PERKINS 4236 / 4	todos	GIR / ALT / BA	V	MMX13X1300
14.150	MWM 6.10	todos	GIR / ALT / BA	multi V	8MM1435

VOLKSWAGEN

14.150	MWM 6.10	nov95/out 97	GIR / ALT / BA	multi V	8MM1400
16.180	MWM 6.10 T	todos	GIR / ALT / BA	multi V	8MM1435
24.220	CUMMINS 6CT 8.3L	jan91/fev00	GIR / ALT / BA	multi V	8MM1420
11.140 / 12.140 C/ MWM	MWM 229 6 CILS.	todos	GIR / ALT / BA	V	MMX10X1175
12.140T	MWM D229EC-6 T	abr97/out97	GIR / ALT / BA	multi V	8MM1400
12-140 H	MWM D229EC-6	jul91/mar98	DH	V	MMX13X1025
12-180 / 14-180 / 14-150	MWM 6.10T	99/00	GIR / ALT / BA	multi V	8MM1445
13-130	MWM	todos	DH	V	MMX13X975
13-130	MWM	todos	GIR / ALT / BA	V	MMX13X1250
13-130	MWM	todos	CPA	V	MMX13X1275
13-190/ 15-190/ 17-210/ 17-2101BG	CUMMINS 6CTAA 8.3L	00/...	GIR / ALT / BA	multi V	8MM1445
14.220/ 16.220	CUMMINS 6CT 8.3L	jan91/fev00	GIR / ALT / BA	multi V	8MM1420
14.220/ 16.220/ 16.300/ 17.300/ 24.250 / 26.300 / 35.300 / 40.300	CUMMINS 6CTAA 8.3L	jan91/fev00	GIR / ALT / BA	multi V	8MM1420
14-140	MWM	todos	DH	V	MMX13X1275
14-150	MWM 6.10 T	jul91/nov95	GIR / ALT / BA	V	MMX13X1300
14-200	MWM 6.10 T	jul91/jul94	ALT	V	MMX13X1300
15-180 / 13-180	MWM 6.10T	00/...	GIR / ALT / BA	multi V	8MM1445
16.170 BT	CUMMINS 6BT 5.9	todos	GIR / ALT / BA	multi V	8MM1435
16.170C / 16.210	CUMMINS 6CT 8.3	95/...	GIR / ALT / BA	multi V	8MM1500

ACD - ar condicionado
ALT - alternador
BA - bomba d'água
BH - bomba hidráulica
BHP - bomba hidr. princ.
CP - comp.

VT - ventilador
CVA - comando de válvula
DH - direção hidráulica
GIR - virabrequim
PLI - polia intermediária
CPA - compressor de ar

(2) Conj. 2 Correias
(3) Conj. 3 Correias



Linha de produtos Magneti Marelli
Correia automotiva para caminhões



MODELO	MOTOR	ANO	APLICAÇÃO	TIPO CORREIA	CÓDIGO
VOLKSWAGEN (cont.)					
16-170 BT / 12-170 BT / 13-170 / 16-200 / 14-170 BT / 15-170	CUMMINS 6BT 5.9L / 6BTAA 5.9L / 6BTAA TURBO	93/00	GIR / ALT / BA	multi V	8MM1445
16-180 CO/ 16-210 CO/ 17-240 OT	MWM 6.10TCA 6.45L	93/01	GIR / ALT / BA	multi V	8MM1445
17.220 / 17.310 / 26.220 / 26.260 / 26.310	CUMMINS	00/...	GIR / ALT / BA	multi V	8MM1420
6.90 / 7.90 / 7.11 / 11.130 / 13.130	MWM	todos	GIR / ALT / BA	V	MMX10X1250
7.100/ 8.100/ 8.140/ 8.140 CO / CE	MWM X-10 4.10L	mar94/set97	GIR / ALT / BA	multi V	8MM1400
7.110 S	MWM TD229 EC-4	out87/mar94	GIR / ALT / BA	V	MMX10X1250
7.110 S	MWM TD229 EC-4	out87/mar94	GIR / DH	V	MMX13X975
7.90 S	MWM D229 EC-4	jan87/mar94	GIR / ALT / BA	V	MMX10X1250
7.90 S	MWM D229 EC-4	jan87/mar94	GIR / DH	V	MMX13X975
CARGO 1215 / 1217 / 1415 / 1417	CUMMINS 6BTAA 5.9L	95/...	GIR / ALT / BA / DH	multi V	8MM1420
L-80	MWM 4.10T 4 CILS.	ago96/out97	GIR / ALT	multi V	8MM1400
FH12 380 4X2 OU 6X4 / FM12 380 6X4 / NH12 380 4X2 OU 6X4	D12C 380 6 CIL	98/...	GIR / ALT / BA / DH / ACD	multi V	10MM1115
FH12 420 4X2 OU 6X4 / FM12 420 6X4 / NH12 420 4X2 OU 6X4	D12C 420 6 CIL	98/...	GIR / ALT / BA / DH / ACD	multi V	10MM1150
FH12 / NH12	340	94/00	GIR / ALT	multi V	8MM1030
FH12 / NH12	340	94/00	GIR / VT	multi V	8MM1050
FH12 / NH12	380	00/...	ALT / GIR	multi V	8MM800
FH12 / NH12	380	00/...	VT / GIR	multi V	8MM955
N / NL 10 / NL 12	TODOS	84/89	GIR / ALT (C/ALT 45A)	V	MMX13X1120
N 10	TD 123 ES TB / TD101		ALT	multi V	10MM1115
N 10 / N12	VOLVO	81/...	GIR / ALT	V	MMX10X1060
N 10 / NL 10 / N 12 / NL 12	VOLVO	84/...	GIR / ALT	V	MMX10X1125
N 1020 (N10)	VOLVO	80/...	GIR / PLI / BA	V	MMX13X1200
N 1220 (N 12)	VOLVO	81/...	GIR / PLI / BA	V	MMX13X1475
NL 10 280 / 310 / 320 / 340	VOLVO	90/...	GIR / ALT / BA	V	MMX13X1525
NL 12 410 - INTERC. (C/ E S/ ACD)	VOLVO	90/...	GIR / ALT / PLI	V	MMX13X1525
NL 12 EDC (C/ E S/ACD)	123 E / 123 ES INTERCOOLER	96/...	GIR / ALT 55AH	V	MMX10X1200
VM 17	MWM 6A206	04/...	GIR / ALT	multi V	8MM975
VM 23	MWM 6A240	04/...	GIR / ALT / ACD	multi V	8MM975
VM17 / VM23	MWM 6A206 / MWM 6A240	04/...	GIR / ALT / ACD	multi V8	MM1376

ACD - ar condicionado
ALT - alternador
BA - bomba d'água
BH - bomba hidráulica
BHP - bomba hidr. princ.
CP - comp.

VT - ventilador
CVA - comando de válvula
DH - direção hidráulica
GIR - virabrequim
PLI - polia intermediária
CPA - compressor de ar

(2) Conj. 2 Correias
(3) Conj. 3 Correias



Linha de produtos Magneti Marelli Correia automotiva para ônibus



MODELO	MOTOR	ANO	APLICAÇÃO	TIPO CORREIA	CÓDIGO
AGRALE					
MA 7.5T (C/ALT. 55AH)	MWM 4.10T 4 CILS.	4.300C	GIR / ALT / BA / DH	multi V	8MM1400
MARCOPOLO VOLARE (S/ACD)	MWM SPRINTER 4 CILS.	98/...	GIR / ALT	multi V	6MM1642
VOLARE MICRO ÔNIBUS A5 / A6	MWM 4.07 T	98/...	VENTILADOR	V	MMX10X900
FORD					
B-12000	MWM 229.4	todos	GIR / ALT / BA / DH	V	MMX13X1188
B-12000	MWM 6 CILS.	80/...	GIR / DH	V	MMX10X1240
B-1618	MWM 6.10 T	90/...	GIR / ALT / BA / DH	multi V	8MM1435
B-1618	MWM 6.10T	90/...	GIR / ALT / BA	multi V	8MM1445
MERCEDES-BENZ					
OF 1714/ OF 1715/ OF 1718	OM366-A	todos	GIR / ALT / BA	V	MMX13X1350
1116 / 1118 / 1317 / 1318 / 1517	MBB - OM 352-A		GIR / ALT / BA	V	MMX13X1475
1516 / 17 / 18 / 2017 / 2216 / 17 - O352	MBB - OM 352-A		GIR / BA / DH	V	MMX13X875
2014 / 2213 / 2214	MBB - OM 352		GIR / BA / DH	V	MMX13X900
712C / 914C	OM-904-LA NO. ORIG. 906.997.0792	98/...	GIR / ALT / BA	multi V	8MM1480
LO-610	364-A	todos	GIR / ALT / BA	V	MMX13X1300
LP1517 / OF 1620	OM366-A	todos	CPA / BA	V	MMX13X1025
O352/ 1113/ LPO - 1313/ 1314/ 1513/ 1514/ 2013	MBB - OM 352		GIR / ALT / BA	V	MMX13X1475
O355	MBB - OM 355 / 5 E 6 CILS.		GIR / PLI / VT	V	MMX13X1015
O355	MBB - OM 355 / 5 E 6 CILS.		GIR / ALT	V	MMX13X1150
O355	MBB - OM 355 / 5 E 6 CILS.		GIR / CPA / BA	V	MMX13X1750
O355	MBB - OM 355 / 5 E 6 CILS.		GIR / PLI	V	MMX13X1875
O362 / A	MBB - OM 352-A		GIR / PLI	V	MMX13X1875
O362 / O364	MBB - OM 352-A		GIR / ALT / BA	V	MMX13X1325
O362 / O364	OM352	todos	PLI / VT	V	MMX13X1025
O362 / OH1316	MBB - OM 352-A		GIR / BA / DH	V	MMX13X975
O364	MBB - OM 352 / 352 - A		GIR / PLI	V	MMX13X1950
O364	OM352	todos	GIR / PLI	V	2XMMX13X1950
O364	MBB - OM 352		GIR / PLI / VT	V	MMX13X1000
O364 / O365 / OF1313 / 1314	MBB - OM 352		GIR / DH	V	MMX13X975
O364 / O370 COM 1 ALT	OM355 5 E 6 CIL / OM352	todos	ALT / ACD	V	2XMMX13X1150
O364 / OH 1419 / 1517	MBB - OM 355 / 5 E 6 CILS.		GIR / PLI	V	MMX13X1950
O370 / O371	MBB - OM 355 / 5 E 6 CILS.		GIR / CPA / BA / DH	V	MMX13X1750
O370 / O371	MBB - OM 355 / 5 E 6 CILS.	todos	GIR / BA / ALT1 / ALT2	V	MMX13X1200
O370 / O371 (E TBÉM C/1 ALT.)	MBB - OM 355 / 5 E 6 CILS.		GIR / ALT / BA	V	MMX13X1050
O370 / O371 RODOV. (C/ACD E C/ 1E2 ALT.)	MBB - OM 355 / 5 E 6 CILS.		GIR / BA / ALT 1-2	V	MMX13X1150
O371	M366-GASOLINA	todos	GIR / PLI / VT	V	MMX13X975
O371	MBB - OM 366		GIR / ALT / BA	V	MMX13X1325
O371 - UP / O400 - UP	MBB - OM 449-A / LA		GIR / ALT / BA	V	MMX13X1718
O371 / O400 / OH 1635L	MBB - OM 447-A / LA		GIR / ALT / BA	V	MMX13X1718
O371 / O400 / OH 1635L	MBB - OM 447-LA		GIR / PLI / VT	V	MMX13X1800
O371 / O400 / OH 1635L	MBB - OM 447-LA / 449-A / LA		GIR / PLI	V	MMX13X1400
O371 / OF1113 / OF1315	OM366-A / M366-GAS.	todos	DH	V	MMX13X925
O371 RODOVIÁRIO	MBB-OM 449-A / LA		GIR / ALT / ACD	V	MMX13X1100
O371 RODOVIÁRIO	MBB - OM 447 / 5 E 6 CILS.		GIR / CPA / BA	V	MMX13X1575
O371-RSD / O400 - RSD	MBB - OM 449-A / LA		GIR / PLI / VT	V	MMX13X1800
O400	MBB - OM 447 / 449		GIR / PLI / VT	V	MMX13X1450
O400	MBB - OM 447 / 449		GIR / ALT / BA	V	MMX13X1750
O400	MBB - OM 447 / 449		GIR / PLI	V	MMX13X1800
O400 C/ ACD THERMO KING	MBB - OM 447 / 449		GIR / CP / ALT	V	MMX13X1050
O500 M / OF 1417	924 LA	todos	GIR / ALT / BA	multi V	8MM1420
O500 R	926 LA		GIR / ALT / BA	multi V	8MM1905
O500 R / RS / RSD	926 LA	01/...	GIR / ALT / BA / DH	multi V	8MM1905

ACD - ar condicionado
ALT - alternador
BA - bomba d'água
BH - bomba hidráulica
BHP - bomba hidr. princ.
CP - comp.

VT - ventilador
CVA - comando de válvula
DH - direção hidráulica
GIR - virabrequim
PLI - polia intermediária
CPA - compressor de ar

(2) Conj. 2 Correias
(3) Conj. 3 Correias



MODELO	MOTOR	ANO	APLICAÇÃO	TIPO CORREIA	CÓDIGO
--------	-------	-----	-----------	--------------	--------

MERCEDES-BENZ (cont.)

OF 1215/ 1313/ 1317/ 1318/ 1320/ 1618/ 1620/ 1714/ 1715/	MBB - OM 366-LA		GIR / DH	V	MMX13X925
OF 1217	OM366-A	todos	GIR / ALT / BA	V	MMX13X1025
OF 1217/ 1290/ 1318/ 1620/ LP-1517	MBB - OM 366-LA		GIR / ALT / BA	V	MMX13X1350
OF 1315 / OH 1315 / O-371-ST	MBB - OM 366 GAS.		GIR / ALT / BA	V	MMX13X1325
OF 1318	OM366-A	todos	GIR / ALT / BA	V	MMX13X1025
OF 1318/ OH 1418	MBB - OM 366-LA		GIR / ALT / BA	V	MMX13X1375
OF 1318/ OH 1418	OM366-A	todos	GIR / ALT / BA	V	MMX13X1025
OF 1618/ 1620/ OH 1313/ 1316	MBB - OM 366		GIR / PLI / VT	V	MMX13X1015
OF 1618/ 1620/ OH 1313/ 1316 C/ALT. 75-AMP.	MBB - OM 366-LA		GIR / PLI / VT	V	MMX13X1375
OF 315/ O371 - ST A GÁS	MBB - OM 366 GÁS		GIR / DH	V	MMX13X925
OF 712/ 812 / 912	MBB - OM 364-A		GIR / ALT / BA	V	MMX13X1300
OF 712/ 912	MBB - OM 364-A		GIR / DH	V	MMX13X950
OF 812	MBB - OM 364-A		GIR / DH	V	MMX13X925
OH 1313/ 1314/ O-362/ OF1113/ O-364	MBB - OM 352		GIR / ALT / BA	V	MMX13X1325
OH 1315	MBB - OM 366-LA		GIR / DH	V	MMX13X975
OH 1315/ 1215/ O371	MBB - OM 366-LA		GIR / ALT / BA	V	MMX13X1325
OH 1315/ 1318 A GÁS	MBB - OM 366 GÁS		GIR / DH	V	MMX13X975
OH 1317/ 1318/ 1319/ 1320	MBB - OM 366-A		GIR / ALT / BA	V	MMX13X1300
OH 1318/ O371/ LP 1218/ 1418/ 1420/ 1517/ 1718/ 2418				V	MMX13X925
OH 1419 / 1517 / O364	MBB - OM 355 / 5 E 6 CILS.		GIR / CPA / BA	V	MMX13X1750
OH 1621	MBB - OM 366-LA	98/...	GIR / PLI	V	MMX13X1600
OH1419 / 1517 / 1518 / O364	MBB - OM 355/ 5 E 6 CILS.	todos	GIR / ALT	V	MMX13X1150

SCANIA

B-111 2ªSÉRIE (C/ALT. BOSCH)		78/...	GIR / ALT / BA	V	MMX13X1625
B-111 2ªSÉRIE (C/ALT. WAPSA)		78/...	GIR / ALT / BA	V	MMX13X1650
BR-115		.../mai 75	GIR / ALT / BA	V	MMX13X1625
BR-116 (C/ALT. BOSCH)		78/84	GIR / ALT / BA	V	MMX13X1625
BR-116 (C/ALT. WAPSA)		78/84	GIR / ALT / BA	V	MMX13X1850
F-114 RODOVIÁRIO	DSC 12 6CIL	todos	GIR / ALT / BA / DH	multi V	8MM1550
F-114-RODOVIÁRIO	TODOS	todos	GIR / ALT / BA / DH	multi V	8MM1538
F94	DSC-911	todos	GIR / ALT / BA / DH S/ACD	multi V	8MM2063
F-94 / L94	DSC911	todos	GIR / ALT / BA / DH / ACD	multi V	8MM2115
K / L - 113		84/...	GIR / ALT / BA	V	MMX13X1900
K-112		83/84	GIR / ALT / BA	V	MMX13X1900
K-112 (C/INTERCOOLER)		87/...	GIR / ALT / BA	V	MMX13X1900
K-112 / K-113		93/...	GIR / PLI / VT	V	MMX13X1500
K-112 / L-113	TODOS	84/...	GIR / ALT / BA	V	MMX13X1863
K-112 / L-113	SCANIA	84/...	GIR / PLI / VT	V	MMX13X1425
K-112 / L-113		84/...	GIR / ALT / BA	V	MMX13X1850
K-113 (C/ACD THERMO KING)		93/...	GIR / ALT / ACD	V	MMX13X1050
K-124	C/ 01 ALT.	98/...	GIR / ALT / BA	multi V	8MM1509
K-124	DSC-1205	98/...	GIR / ALT / BA C / 2 ALT	multi V	8MM2063
L-94	DSC-911	todos	GIR / ALT / BA / DH S/ACD	multi V	8MM2585
R 164	DSC-1602	03/...	GIR / ALT / BA / DH / ACD	multi V	8MM2085
R 164	NZ 480	03/...	GIR / ALT / BA / DH S/ACD	multi V	8MM1255

VOLARE

A5 / A6	MWM 4.07 T	98/...	GIR / BA / DH / ACD	multi V	6MM2115
A5 / A6	MWM 4.07T	98/...	GIR / BA / DH	multi V	6MM1642
A8	MWM 4.10T	00/...	GIR / ALT / DH	multi V	6MM1375
A8	MWM 4.10T	00/...	GIR / ALT / DH C/ACD UX 20	multi V	6MM1800
A8	MWM 4.10T	00/...	GIR / ALT / DH C/ACD TM16	multi V	6MM1850

ACD - ar condicionado
ALT - alternador
BA - bomba d'água
BH - bomba hidráulica
BHP - bomba hidr. princ.
CP - comp.

VT - ventilador
CVA - comando de válvula
DH - direção hidráulica
GIR - virabrequim
PLI - polia intermediária
CPA - compressor de ar

(2) Conj. 2 Correias
(3) Conj. 3 Correias



Linha de produtos Magneti Marelli
Correia automotiva para ônibus



MODELO	MOTOR	ANO	APLICAÇÃO	TIPO CORREIA	CÓDIGO
VOLKSWAGEN					
14-140	MWM	todos	DH	V	MMX13X1275
14-150	MWM	91/95	GIR / ALT / BA	V	MMX13X1300
14-150	MWM 6.10T	nov95/out97	GIR / ALT / BA	multi V	8MM1400
14-200	MWM	todos	GIR / ALT / BA	V	MMX13X1300
16-180	MWM 6.10 T	todos	GIR / ALT / BA	multi V	8MM1440
17-240 OT (C/ ACD)	MWM	00/...	GIR / ALT / BA	multi V	8MM1500
18-320 EOT	CUMMINS ISC	04/...	GIR / ALT	multi V	8MM1900
8-140/ 8-140 CO/ CE	MWMX 10 4.10T	mar94/set97	GIR / ALT / BA	multi V	8MM1400
12-180/ 14-180/ 14-150	MWM 6.10T	99/00	GIR / ALT / BA	multi V	8MM1445
12-180/ 14-180/ 14-150	MWM 6.10T	99/00	GIR / ALT / BA	multi V	8MM1445
13-190/ 15-190/ 17-210/ 17-2101BG	CUMMINS 6CTAA 8.3L	00/...	GIR / ALT / BA	multi V	8MM1445
15-180 / 13-180	MWM 6.10T	00/...	GIR / ALT / BA	multi V	8MM1445
16-170 BT/ 12-170 BT/ 13-170/ 16-200/ 14-170 BT/ 15-170	CUMMINS 6BT 5.9L / 6BTAA 5.9L / 6BTAA TURBO	93/00	GIR / ALT / BA	multi V	8MM1445
16-180 CO/ 16-210 CO/ 17-240 OT	MWM 6.10TCA 6.45L	93/01	GIR / ALT / BA	multi V	8MM1445
ONIBUS 18310 / 1724	MWM/CUMMINS-TRAS.	01/...	GIR / ALT / BA	multi V	8MM1530
ONIBUS 18310 / 1724	MWM/CUMMINS-TRAS.	01/...	GIR / ALT / BA	multi V	8MM2585
ONIBUS PROTEUS	MWM-17240 TRASEIRO	01/...	ALT / 140 AMPERES	multi V	8MM1560
ONIBUS PROTEUS	MWM-17240 TRASEIRO	01/...	VENTILADOR / RADIADOR	multi V	8MM2523

VOLVO					
B10M	340	94/...	GIR / ALT	V	MMX10X1125
B-10M (C/2 ALT. 45AH)		87/...	GIR / ALT1 / ALT2	V	MMX10X1200
B-12		94/...	GIR / VT	V	MMX13X1400
B-12		94/...	GIR / VT	V	MMX10X1400
B-12 B	TODOS	97/...	VENT	V	MMX13X1410
B-12R	D12D 380	todos	GIR / ALT / BA / DH / ACD	multi V	10MM1115
B-12R	D12D 420	todos	GIR / ALT / BA / DH / ACD	multi V	10MM1150
B-58 (C/ALT. 75AH)	TODOS	84/...	GIR / ALT	V	MMX10X1250
B-58 E (C/ALT. 45AH)		86/...	GIR / ALT	V	MMX10X1200
B7R	D 7B230/ D 7B260 / D 7A285	02/...	GIR / ALT	V	MMX10X1175



Linha de produtos Magneti Marelli
Correia automotiva para máquinas
e implementos agrícolas



MODELO	MOTOR	ANO	APLICAÇÃO	TIPO CORREIA	CÓDIGO
AGRALE					
4100	TODOS	todos	GIR / ALT	V	MMX13X950
4200 / 4300	TODOS	todos	GIR / ALT	V	MMX13X1325
5060 / 5060.4	ZETOR 5201 T	todos	GIR / ALT / VT	V	MMX13X1175
5070 / 5070.4	ZETOR 7701	todos	GIR / ALT / VT	V	MMX13X1175
5080 / 5080.4	ZETOR 7301	todos	GIR / ALT / VT	V	MMX13X1175
BX 6150	MWM TD229EC6 TURBO	todos	GIR / ALT / VT	V	MMX13X1375
BX100 / 130 / 4100 / 4130 / BX4.9 / BX90	MWM TD229 EC6	todos	GIR / ALT / VT	V	MMX13X1375

BABER GREENE					
20VG / 22VG	MWM D229.4 4 CILS.	.../90	GIR / VT	V	MMX13X1250
40VG	MWM TD229 EC6	todos		V	MMX13X1375

CATERPILLAR					
834			GIR / GER / BA	V	MMX13X1600
621-B			GIR / VT (3)	V	MMX13X1750
824-B			GIR / VT-ALT (2)	V	MMX13X1600
CA1170	MWM D229.4 4 CILS.	.../90	GIR / VT	V	MMX10X1238
CA1175	MWM D229.4 4 CILS.	.../90	GIR / VT	V	MMX13X1250
CA1175	MWM TD229 EC6	todos	GIR / ALT / VT	V	MMX13X1375
D-3306 / D-379			GIR / ALT	V	MMX13X950
D-333			GIR / ALT	V	MMX13X975
D8H			GIR / ALT	V	MMX13X1600

CBT					
1000	PERKINS 4203	72/...	GIR / ALT / BA	V	MMX13X1350
1020	MBB - OM 321	62/66	GIR / ALT / BA	V	MMX13X1450
1065	MBB - OM-314	73/...	GIR / ALT / BA	V	MMX13X1260
1090	PERKINS		GIR / ALT / BA	V	MMX13X1300
2105	MBB - OM - 353		GIR / BA / DH	V	MMX13X875
2105	MBB - OM 352		GIR / ALT / BA (2)	V	MMX13X1475
2500	PERKINS 6358		GIR / ALT / BA (2)	V	MMX13X1250
2600	MBB - OM - 353		GIR / ALT / BA	V	MMX13X875
2600	MBB - OM 352		GIR / BA / DH	V	MMX13X1475
8240	PERKINS ÁLCOOL 4236		GIR / ALT / BA	V	MMX13X1260
8240	PERKINS DIESEL 4248		GIR / ALT / BA	V	MMX13X1350
8440	MWM (D229-4)	.../90	GIR / VT	V	MMX13X1250
8440	MWM((D229-4)		GIR / ALT / BA / VT	V	MMX10X1175
8450	MWM TD229 EC6	todos	GIR / ALT / VT	V	MMX13X1375
1090 / 1090-A / 1105	MBB - OM 352	todos	GIR / ALT / BA (2)	V	MMX13X1475
1090 / 1090-A / 1106	MBB - OM - 352	todos	GIR / BA / DH	V	MMX10X865
2400 INT	DETROIT DIESEL 453N	todos	GIR / ALT / BA	V	MMX13X1075
8060 (4X4) TURBO	MBB - OM 352		GIR / ALT / BA / VT	V	MMX13X1500
824.B	D.333	todos	GIR / ALT	V	MMX13X975

CLAAS CONSUL					
CLAAS CONSUL	MARCADOR DE VELOCIDADE		POLIAS MOV./ MOTORA	V	MMX10X865
CLAAS CONSUL			GIR / ALT / BA / VT	V	MMX13X1260

CLARK CONSUL					
65R / 75HD			GIR / ALT / BA	V	MMX13X1250
C500 X 50	PERKINS 4 CILS.			V	MMX13X1225
CLARK 55	MBB - OM 352 (DIESEL)		GIR / ALT / BA	V	MMX13X1475
CLARK GUINDASTE 714			GIR / ALT / BA	V	MMX13X1450
MICHIGAN 45C	MBB - OM 352		GIR / ALT / BA	V	MMX13X1475

ACD - ar condicionado
ALT - alternador
BA - bomba d'água
BH - bomba hidráulica
BHP - bomba hidr. princ.
CP - comp.

VT - ventilador
CVA - comando de válvula
DH - direção hidráulica
GIR - virabrequim
PLI - polia intermediária
CPA - compressor de ar

(2) Conj. 2 Correias
(3) Conj. 3 Correias



Linha de produtos Magneti Marelli
Correia automotiva para máquinas
e implementos agrícolas



MODELO	MOTOR	ANO	APLICAÇÃO	TIPO CORREIA	CÓDIGO
--------	-------	-----	-----------	--------------	--------

CLARK CONSUL (cont.)

MICHIGAN 75	MBB - OM 321 (DIESEL)		GIR / ALT / BA	V	MMX13X1450
MICHIGAN 75	PERKINS 6340 (DIESEL)		GIR / ALT / BA	V	MMX13X1250

CLAYSON CONSUL

1530			GIR / ALT / BA / VT	V	MMX13X1175
4040	MBB - OM 352		GIR / ALT / BA / VT	V	MMX13X1475
89 / 122 / 133 / 135			GIR / ALT / BA / VT	V	MMX13X1200

CUMMINS MOTORS

MOTOR 855NT - VEICULAR			GIR / ALT(2)	V	MMX13X1175
------------------------	--	--	--------------	---	------------

EATON

134 A	MBB - OM 321	todos	GIR / ALT / BA	V	VMMX13X1450
134 A	MBB - OM 352	todos	GIR / ALT / BA	V	MMX13X1475
G51 / 030 / 050	CHRYSLER	65/...	BOMBA.HIDR.PRINCIPAL (2)	V	MMX13X1025
G51 / 050	WILLYS	65/...	GIR / ALT	V	MMX10X1238
G51 / 050	WILLYS	65/...	GIR / BA(2)	V	MMX10X1238
G51P	WILLYS	todos	GIR / BA	V	MMX10X1238
G51P / L	PERKINS		GIR / ALT / BA	V	MMX13X1250
G83P	PERKINS		GIR / ALT / BA	V	MMX13X1250
TROJAN 1500B / 1900B	MBB - OM 352	todos	GIR / ALT / BA	V	MMX13X1475
TROJAN 3000B	SCANIA	todos	GIR / ALT / BA	V	MMX13X1525

FIAT ALLIS

1900B	MBB - OM 352		GIR / ALT / BA	V	MMX13X1475
7D	MWM D229.6 6 CILS.	todos	GIR / ALT / VT	V	MMX13X1425
AD-14			GIR / ALT / BA (2)	V	MMX13X1325
AD-14C	SCANIA		GIR / ALT	V	MMX13X1000
AD-14C	SCANIA		GIR / VT (2)	V	MMX13X1525
AD-7B	MWM (D225/6)		GIR / ALT / BA	V	MMX13X1425
AD-7B / AD7C	MWM D229.6 6 CILS.	todos	GIR / ALT / VT	V	MMX13X1425
AD-7C	MOTOR ITALIANO		GIR / ALT / BA	V	MMX13X1300
AD-7C			GIR / ALT / BA	V	MMX10X850
FA 120	MWM D229 .6 6 CILS.	todos	GIR / ALT / VT	V	MMX13X1350
FA120 / FD9	MWM TD229 EC6	todos	GIR / ALT / VT	V	MMX13X1375
FB80 / FE105 / FE105B	MWM D229.6 6 CILS.	todos	GIR / ALT / VT	V	MMX13X1425
FD9	MWM D229 .6 6 CILS.	todos	GIR / ALT / VT	V	MMX13X1350
FD9B	MWM D229 .6 6 CILS.	todos	GIR / ALT / VT	V	MMX13X1350
FG70 / FR10	MBB - OM 352		GIR / ALT / BA	V	MMX13X1475
FR10B	MWM D229.4 (12V)	.../90	GIR / VT	V	MMX13X1250
FR11B	MWM D229.4 4 CILS.	.../90	GIR / VT	V	MMX13X1250
FR12B	MWM D229.4 (12V)	.../90	GIR / VT	V	MMX13X1250
FR14	MWM D229.4	.../90	GIR / VT	V	MMX13X1250

FORD

4600 / 4800 / 5600 / 6600			GIR / ALT / BA	V	MMX13X1400
4610 / 4810 / 5610 / 6610			GIR / ALT / BA	V	MMX13X1425

HYSTER

EMPILHADEIRAS		84/...	GIR / ALT (2)	V	MMX13X1575
EMPILHADEIRAS H-165-H			GIR / VT	V	MMX13X1450
EMPILHADEIRAS H-50-K			GIR / VT	V	MMX13X1175
EMPILHADEIRAS YE-40 / H	CONTINENTAL		GIR / ALT	V	MMX13X1450
GUINDASTE KF	WILLYS		GIR / ALT	V	MMX10X950

ACD - ar condicionado
ALT - alternador
BA - bomba d'água
BH - bomba hidráulica
BHP - bomba hidr. princ.
CP - comp.

VT - ventilador
CVA - comando de válvula
DH - direção hidráulica
GIR - virabrequim
PLI - polia intermediária
CPA - compressor de ar

(2) Conj. 2 Correias
(3) Conj. 3 Correias



Linha de produtos Magneti Marelli
Correia automotiva para máquinas
e implementos agrícolas



MODELO	MOTOR	ANO	APLICAÇÃO	TIPO CORREIA	CÓDIGO
--------	-------	-----	-----------	--------------	--------

IDEAL STANDARD

1170		.../nov 83	GIR / ALT / BA / VT	V	MMX10X1238
1170		.../nov 83	GIR / PLI / DH	V	MMX13X1350

KOMATSU

D-30 E-16B	MBB - OM 352		GIR / ALT / BA	V	MMX13X1450
D-50 A-15C	MBB - OM 352		GIR / DH	V	MMX13X950
D-60 A-6B	CUMMINS 855 NT		GIR / ALT / BA	V	MMX13X1450
D-60 E-6B	CUMMINS 855 NT		GIR / DH	V	MMX13X950

LAVRALE

L300	MWM TD229.4 4 CILS.	.../90	GIR / VT	V	MMX10X1238
------	---------------------	--------	----------	---	------------

MASSEY FERGUSON

MF-1630			GIR / ALT / BA	V	MMX13X1350
MF-187 / MF-210			GIR / ALT / BA	V	MMX13X1250
MF-220 / 220-A	PERKINS A-4248	72/...	GIR / ALT / BA	V	MMX13X1350
MF-235 CAFEIRO	3 CILS.	72/...	GIR / ALT / BA	V	MMX13X1200
MF-235 ST	A-3152 3 CILS.	72/...	GIR / ALT / BA	V	MMX13X1200
MF-250	PERKINS 3 CILS. AD3152	todos	GIR / ALT / BA / VT	V	MMX13X1235
MF-250 ST	3 CILS.	72/...	GIR / ALT / BA	V	MMX13X1200
MF-265 / 275 / 290		84/...	GIR / ALT / BA	V	MMX13X1425
MF-265 / MF-265 / SE	PERKINS 4 CILS. A 4236 DERATED	todos	GIR / ALT / BA / VT	V	MMX13X1425
MF-265 ST	PERKINS 4 CILS.4203	72/83	GIR / ALT / BA	V	MMX13X1250
MF-275 / MF-283 / MF-290	PERKINS 4 CILS. 4000	todos	GIR / ALT / BA / VT	V	MMX13X1425
MF-275 HI-CL	4236 4 CILS.	76/83	GIR / ALT / BA	V	MMX13X1350
MF-275 ST	4 CILS.	72/78	GIR / ALT / BA	V	MMX13X1350
MF-285 ST / MF-290 ST	A-4248 4 CILS.	76/83	GIR / ALT / BA	V	MMX13X1350
MF-292	PERKINS 4 CILS. P 4000 T	todos	GIR / ALT / BA / VT	V	MMX13X1600
MF-295		84/...	GIR / ALT / BA	V	MMX13X1325
MF-296		84/...	GIR / ALT / BA	V	MMX13X1525
MF-297	PERKINS 6 CILS.1006.6	todos	GIR / ALT / VT	V	MMX13X1250
MF-299	PERKINS 6 CILS.1006.6 T	todos	GIR / ALT / VT	V	MMX13X1250
MF-300	PERKINS A-6357	72/...	GIR / ALT / BA	V	MMX13X1350
MF-300			GIR / ALT / BA	V	MMX13X1250
MF-3366	A-6357	todos	GIR / ALT / BA	V	MMX13X1350
MF-3366	A-6357	todos	GIR / ALT / BA (2)	V	MMX13X1425
MF-3640 (ATÉ SÉRIE 1578)			GIR / ALT / BA	V	MMX13X1350
MF-3640 (SÉRIE 1579 EM DIANTE)			GIR / ALT / BA	V	MMX13X1250
MF-400 / 410 / 510			GIR / ALT / BA (2)	V	MMX13X1425
MF-500			GIR / ALT / BA (2)	V	MMX10X1025
MF-50X	A-3152	todos	GIR / ALT / BA (2)	V	MMX13X1200
MF-50X ESTREITO	A-3152	todos	GIR / ALT / BA	V	MMX13X1200
MF-5275 / 2	PERKINS 4 CILS. 4001	todos	GIR / ALT / BA / VT	V	MMX13X1375
MF-5275 / 4	PERKINS 4 CILS. 4001	todos	GIR / ALT / BA / VT	V	MMX13X1375
MF-5290 / 2	PERKINS 4 CILS. 4001	todos	GIR / ALT / BA / VT	V	MMX13X1375
MF-5290 / 4	PERKINS 4 CILS. 4001	todos	GIR / ALT / BA / VT	V	MMX13X1375
MF-5300 / 2 E / 4	PERKINS 4 CILS. 4001 T	todos	GIR / ALT / VT	V	MMX13X1425
MF-5300 / 2 E / 4	PERKINS 4 CILS.4001T	todos	GIR / ALT / CP	V	MMX13X1015
MF-5310 / 2 E / 4	PERKINS 4 CILS. 4001 T	todos	GIR / ALT / VT	V	MMX13X1425
MF-5310 / 2 E / 4	PERKINS 4 CILS.4001T	todos	GIR / ALT / CP	V	MMX13X1015
MF-5320 / 2 E / 4	PERKINS 6 CILS.1006.6	todos	GIR / ALT / CP	V	MMX13X1015
MF-5320 / 2 E / 4	PERKINS 6 CILS.1006.6	todos	GIR / ALT / VT	V	MMX13X1425
MF-55X	A-3152	todos	GIR / ALT / BA	V	MMX13X1250
MF-5650			GIR / ALT / BA	V	MMX13X1525
MF-610	PERKINS 4 CILS. 4000	todos	GIR / ALT / BA / VT	V	MMX13X1375
MF-620	PERKINS 4 CILS. 4000	todos	GIR / ALT / VT	V	MMX13X1525
MF-630	PERKINS 6 CILS. 1006.6	todos	GIR / ALT / VT	V	MMX13X1600

ACD - ar condicionado
ALT - alternador
BA - bomba d'água
BH - bomba hidráulica
BHP - bomba hidr. princ.
CP - comp.

VT - ventilador
CVA - comando de válvula
DH - direção hidráulica
GIR - virabrequim
PLI - polia intermediária
CPA - compressor de ar

(2) Conj. 2 Correas
(3) Conj. 3 Correas



Linha de produtos Magneti Marelli
Correia automotiva para máquinas
e implementos agrícolas



MODELO	MOTOR	ANO	APLICAÇÃO	TIPO CORREIA	CÓDIGO
--------	-------	-----	-----------	--------------	--------

MASSEY FERGUSON (cont.)

MF-640 / MF-650 / MF-660 / MF-680	PERKINS 6 CILS.1006.6 T	todos	GIR / ALT / VT	V	MMX13X1600
MF-650 / MF-660 / MF-680	PERKINS 6 CILS.1006.6T	todos	GIR / ALT / CP	V	MMX13X1235
MF-65X / 65R (SERV.AGRÍCOLA)	AD-4203	72/...	GIR / ALT / BA	V	MMX13X1250
MF-85X	A-4248	todos	GIR / BA	V	MMX10X1238
MF-85X	MWM	todos	GIR / BA	V	MMX10X1238
MF-951	A-4248	todos	GIR / ALT / BA	V	MMX13X1350
MF-95X	A-6357	todos	GIR / ALT / BA	V	MMX13X1325
MF-95X / 95XT		72/...	GIR / ALT / BA	V	MMX13X1350

MÜLLER

TM12	MWM D229.6 6 CILS.	todos	GIR / ALT / VT	V	MMX13X1425
TM12 / TM16	MWM TD229 EC6	todos	GIR / ALT / VT	V	MMX13X1375
VAP55	MWM D229.4	.../90	GIR / VT	V	MMX13X1250
VAP55	MWM D229.6 6 CILS.	.../90	GIR / VT	V	MMX10X1238

MWM

D-229-3 / D-229-6 / D-229-6 / C/ CPA D-229-6 C/ BV			GIR / ALT / BA	V	MMX10X1250
D-229-4 BASICO			GIR / ALT / BA	V	MMX10X1175
TD-229-6			GIR / ALT / BA (2)	V	MMX13X1175

NEW HOLLAND

4610 / 5610 / 6610	GENESIS	todos	GIR / VT / BA	V	MMX13X1410
7630 / 7630TR / 7810 / 7830 / 8030	GENESIS BSD 450TURBO	todos	GIR / BA / BH / VT	V	MMX13X1175
TL65 / TL70 / TL80 / TL90 / TL100	IVECO 8035.05	todos	GIR / VT / BA	V	MMX10X1190

SANTA MATILDE

SM-1000 / SM-1200	MBB - OM 352		GIR / ALT / BA	V	MMX13X1475
SM-1000 / SM-1200 / SM-5105	MWM-D 225-6		GIR / ALT / BA	V	MMX10X1238
SM-300 C	PERKINS 3152		GIR / ALT / BA	V	MMX13X1200
SM-300 CR	PERKINS 4236		GIR / ALT / BA	V	MMX13X1350
SM-400 CR	PERKINS 4203		GIR / ALT / BA	V	MMX13X1250
SM-500 CR	PERKINS 4248		GIR / ALT / BA	V	MMX13X1350

SCHNEIDER LOGEMANN

MOD.1000 COXILHA/ ARROZEIRA		todos	GIR / ALT	V	MMX13X975
SLC-2000			POLIA MOV / FILTRO	V	MMX10X1035
SLC-2000 / SLC-6200			GIR / ALT / BA	V	MMX13X1450
SLC-6200			TACÔMETRO DO CILINDRO	V	MMX10X980

SLS JOHN DEERE

7500	MWM D229.6 6 CILS.	todos	GIR / ALT / BA / VT	V	MMX13X1425
7500 SEM CABINE	JOHN DEERE 6068T TURBO 4 CILS.	todos	GIR / ALT / BA / VT	V	MMX13X1450
6600 / 7500	JOHN DEERE 6059T TURBO 6 CIL / 6068T TURBO 6 CIL	todos	GIR / ALT / VT	V	MMX13X1485
7810	JOHN DEERE 6068 TURBO 6 CIL	todos	GIR / BA / DH / VT+F228ACD	multi V	8MM2063

SPERRY NEW HOLLAND

SNH-122 / 133 / 135 / 140	FORD		GIR / ALT / BA	V	MMX13X1200
SNH-1530	MBB - OM 352		GIR / ALT / BA	V	MMX13X1175
SNH-4040 / SNH-5050	MBB - OM 352		GIR / ALT / BA	V	MMX13X1475

TEMA-TERRA

SP-10000	MBB - OM 314	todos	GIR / ALT / BA	V	MMX13X1260
SP-10000	PERKINS 6-357	todos	GIR / ALT	V	MMX13X1200

ACD - ar condicionado
ALT - alternador
BA - bomba d'água
BH - bomba hidráulica
BHP - bomba hidr. princ.
CP - comp.

VT - ventilador
CVA - comando de válvula
DH - direção hidráulica
GIR - virabrequim
PLI - polia intermediária
CPA - compressor de ar

(2) Conj. 2 Correias
(3) Conj. 3 Correias



Linha de produtos Magneti Marelli
Correia automotiva para máquinas
e implementos agrícolas



MODELO	MOTOR	ANO	APLICAÇÃO	TIPO CORREIA	CÓDIGO
--------	-------	-----	-----------	--------------	--------

TEMA-TERRA (cont.)

SP-6000	MBB - OM 321	todos	GIR / ALT	V	MMX13X1425
---------	--------------	-------	-----------	---	------------

TEREX

72/31	DETROIT DIESEL 4-71N		GIR / VT (2)	V	MMX13X1575
72-21	DETROIT DIESEL 3-71N		GIR / VT (2)	V	MMX13X1600
72-41	DETROIT DIESEL 4-71N		GIR / VT / ALT (2)	V	MMX13X1525
72-51	DETROIT DIESEL 6-71N		GIR / VT / ALT (2)	V	MMX13X1525
72-71	DETROIT DIESEL 8V-71T		GIR / ALT(2)	V	MMX13X1150
72-71	DETROIT DIESEL 8V-71T		GIR / VT (3)	V	MMX13X1650
72-71B			GIR / ALT(2)	V	MMX10X1150
72-71B			GIR / BA(2)	V	MMX13X975
72-81	DETROIT DIESEL 12V-71T		GIR / ALT	V	MMX13X825
72-81	DETROIT DIESEL 12V-71T		GIR / VT (3)	V	MMX13X1225
R-22			GIR / VT (2)	V	MMX13X1750
R-35B			GIR / ALT	V	MMX13X975
R-35B			GIR / VT (2)	V	MMX13X1600
TS-14B	DETROIT DIESEL 4-71N (2 MOTORES)		GIR / ALT(2)	V	MMX10X990
TS-14B	DETROIT DIESEL 4-71N (2 MOTORES)		GIR / CPA (2)	V	MMX13X1000
TS-14B	DETROIT DIESEL 4-71N (2 MOTORES)		GIR / VT (3)	V	MMX13X1375
TS-24B	DETROIT DIESEL 12V-71N		GIR / ALT	V	MMX13X975

VALMET

134-4 TURBO		84/...	GIR / ALT / BA	V	MMX13X1425
3000-E	3 CILS.	72/...	GIR / ALT / BA	V	MMX10X1238
65-ID ST / 62-ID	3 CILS.	72/...	GIR / ALT / BA	V	MMX10X1238
68 / 88		81/...	GIR / ALT / BA	V	MMX10X1238
85/86-ID ST	4 CILS.	72/...	GIR / ALT / BA	V	MMX10X1238
CAFEEIRO	3 CILS.	72/...	GIR / ALT / BA	V	MMX10X1238
SINCHRO - O - MATIE		72/...	GIR / ALT / BA	V	MMX10X1238

VALTRA VALMET

685	MWM D229.3 3 CILS.	todos	GIR / ALT / BA / VT	V	MMX13X1250
785	MWM D229.4 4 CILS.	todos	GIR / ALT / BA / VT	V	MMX13X1250
800	VALMET 420 DR 4 CILS.	todos	GIR / ALT / BA / VT	V	MMX13X1300
1580	MWM TD 229 EC6 VM TURBO	todos	GIR / ALT / BA / VT	V	MMX13X1425
1780	MWM TD 229 EC6 VA TURBO	todos	GIR / ALT / BA / VT	V	MMX13X1425
1180S	VALMET 620 D 6 CILS.	todos	GIR / ALT / BA / VT	V	MMX13X1400
1280R	MWM D229.6VW 6 CILS.	todos	GIR / ALT / BA / VT	V	MMX13X1425
1380S / 1680S / 1880S	VALMET 620 DS 6 CILS.	todos	GIR / ALT / BA / VT	V	MMX13X1400
600 / 700	VALMET 320 D 3 CILS.	todos	GIR / ALT / BA / VT	V	MMX13X1325
885S	VALMET 420 D 3 CILS.	todos	GIR / ALT / BA / VT	V	MMX13X1325
885TS / 985S	VALMET 420 DS 4 CILS.	todos	GIR / ALT / BA / VT	V	MMX13X1325
ATS	MWM D229.3 3 CILS.	todos	GIR / ALT / BA / VT	V	MMX13X1250

YANMAR VALMET

1030 SÉRIE YB	BTD22T	96/99	GIR / ALT / VT	V	MMX13X990
1040 SÉRIE YB	BTD33T	87/99	GIR / ALT / VT	V	MMX13X990
1050D SÉRIE YB	BTD33T / BTD40	87/99	GIR / ALT / VT	V	MMX13X990

ACD - ar condicionado
ALT - alternador
BA - bomba d'água
BH - bomba hidráulica
BHP - bomba hidr. princ.
CP - comp.

VT - ventilador
CVA - comando de válvula
DH - direção hidráulica
GIR - virabrequim
PLI - polia intermediária
CPA - compressor de ar

(2) Conj. 2 Correias
(3) Conj. 3 Correias

linha de
produtos

MAGNET
MARE

**filtro de ar, cabine
óleo e combustível**



MODELO/ MOTOR		ar	óleo	combustível	cabine	diversos	tipo filtro
							

AGRALE

CAMINHÕES

4000-Serie

4000 D - MWM D229/4 Diesel

01/85- FA7108 FO123 FOC1059 FA805 ES

4500 - MWM D229/4

01/94- FO123

5000-Serie

5000 RD - MWM D229/4

01/94- FA7108 FO123 FOC1059 FA805 ES

6000 (Furgovan)

Furgovan 6000 - 2.8MWM Sprint 4.07TCA

01/02- FA3003 FO340 FOC450/1 FA203 ES

Separador de água

FOC970/1

Furgovan 6000 E - MWM 4.07 TCE

01/05- FA3003 FO340 FA203 ES

Furgovan 6000 E - MWM 4.08 TCE

01/05- FA3003 FO340 FA203 ES

6000-Serie

6000 - RS/RD/CD - 2.8MWM Sprint4.07TCA

01/00- FA3003 FO340 FOC450/1 FA203 ES

Separador de água

FOC970/1

7000-Serie

7000 - MWM 4.10 T

01/93- FO962

-12/99 FA9834 FA820 ES

-05/00 FOC450/1

01/00- FA3003 FA203 ES

Separador de água

FOC970/1

7500 - MWM 4.10 TCA

01/94- FO962

-12/99 FA9834 FA820 ES

-05/00 FOC450/1

01/00- FA3003 FA203 ES

Separador de água

FOC970/1

8000 (Furgovan)

Furgovan 8000 - MWM 4.10 TCA

01/03- FA3003 FO962 FOC450/1 FA203 ES

Separador de água

FOC530/1

8000-Serie

8500 - MWM 4.10 TCA

01/98- FO962

-12/99 FA9834 FA820 ES

-05/00 FOC450/1

01/00- FA3003 FA203 ES

Separador de água

FOC970/1

8500 E-Tronic - MWM 4.12 TCE

03/06- FA3003 FO962 FA203 ES

9000-Serie

9200 E-Mec - MWM 4.10 TCA

01/03- FA3003 FO962 FOC450/1 FA203 ES

Separador de água

FOC530/1

9200 E-Tronic - MWM 4.12 TCE

03/06- FA3003 FO962 FA203 ES

ÔNIBUS

Serie MA / MT

MA 5.0 E - MWM 4.07 TCE

01/02- FA3003 FO340 FA203 ES

MA 5.0 E - MWM 4.08 TCE

01/05- FA3003 FO340 FA203 ES

MA 6.0 E - MWM 4.07 TCE

01/05- FA3003 FO340 FA203 ES

MA 6.0 E - MWM 4.08 TCE

01/05- FA3003 FO340 FA203 ES

MA 7.0 - MWM 4.10 T

01/97- FA9834 FO962 FA820 ES

Separador de água

-05/00 FOC450/1

Separador de água

FOC970/1

MA 7.5 - E-Tronic - MWM 4.12 TCE

01/05- FA3003 FO962 FA203 ES

MA 7.5 T - MWM 4.10 TCA

01/96- FA9834 FO962 FA820 ES

Separador de água

-05/00 FOC450/1

Separador de água

FOC970/1

MA 7.9 - MWM 4.10 TCA

03/06- FA3003 FO962 FOC450/1 FA203 ES

Separador de água

FOC530/1



Linha de produtos Magneti Marelli
Filtro ar, óleo, cabine e combustível



MODELO/ MOTOR		ar	óleo	combustível	cabine	diversos	tipo filtro

AGRALE (cont.)

ÔNIBUS

Serie MA / MT

MA 8.0 - MWM 4.10 TCA Separador de água	01/05-	FA3003	FO962	FOC450/1 FOC530/1		FA203	ES
MA 8.5 - MWM 4.10 TCA Separador de água	01/96- -05/00	FA9834	FO962	FOC450/1 FOC970/1		FA820	ES
MA 8.5 - E-Tronic - MWM 4.12 TCE	01/05-	FA5134	FO962				
MA 8.5 T - Cummins 6BTAA Separador de água	01/04-	FA3003	FO280	FOC970/1		FA203	ES
MA 9.2 - MWM 4.10 TCA Separador de água	01/02-	FA3003	FO962	FOC450/1 FOC530/1		FA203	ES
MA 9.2 - E-Tronic - MWM 4.12 TCE	01/06-	FA5134	FO962				
MA 12.0 E - Cummins Int. 4 ISBE	01/06-	FA5134					
MT 12.0 - LE/SB - Cummins Int. 4 ISBE	01/06-	FA5134					
MT 12.0 - LE/SB - Cummins Int. 6 ISBE	01/06-	FA5134					

Serie TX

TX 1100 - M790 Separador de água	01/82-		FO171	FOC72/2 FOC530/1			
TX 1200 - GM 4151 (Álcool)	01/83-	FA3589					
TX 1600 - GM 4151 (Álcool)	01/83-	FA3589					

Serie Volare

Volare A5 - MWM 4.07 TCA Separador de água	01/00-	FA3003	FO340	FOC450/1 FOC970/1		FA203	ES
Volare A6 - MWM 4.07 TCA	01/98- -12/99	FA9834	FO340			FA820	ES
	01/00-	FA3003				FA203	ES
Para referência original: 6008.006.035.00.7 Separador de água / Parcialmente/ou	-12/01			FOC498 FOC970/1 FOC450/1 FOC530/1			
Separador de água / Parcialmente/ou Separador de água	01/02-						
Volare A8 - MWM 4.10 TCA	01/98- -12/99	FA9834	FO962			FA820	ES
	01/00-	FA3003				FA203	ES
Separador de água Separador de água	-05/00 06/00-			FOC450/1 FOC970/1			
Volare W8 - MWM 4.12 TCE	03/06-	FA3003	FO962			FA203	ES
Volare W9 - MWM 4.12 TCE	11/06-	FA3003	FO962			FA203	ES

CLARK

A-Serie

A25 - Cummins 6CTAA 8.3		FA4650/1		FOC72/2		FA840 FRA33	ES Refr.
Pré-filtro				FOC410			

FIAT

100-Serie

120 - 8360 Nacional	01/78-12/84	FA9834	FO339			FO346 FA820	H ES
130 - CP 3 Importado	-01/77					FO346	H
130 - CP 3 Nacional	01/78-01/83	FA4650/1	FO339	FOC72/2		FO346 FA840	H ES
140 - 8360 Nacional	01/78-12/84	FA9834	FO339			FO346 FA820	H ES

CB - Câmbio
DH - Direção hidráulica
ES - Elemento de segurança

FAS - Filtro do ar seco
FC - Filtro do ar para cabine
H - Hidráulico

PC - Precarga
TR - Transmissão hidráulica
Refr. - Filtro de refrigeração

filtro

ISI



MODELO/ MOTOR		ar 	óleo 	combustível 	cabine 	diversos 	tipo filtro
---------------	---	---	---	--	---	---	-------------

FIAT (cont.)

MODELO/ MOTOR		ar	óleo	combustível	cabine	diversos	tipo filtro
100-Serie							
180 - FNM	01/63-12/75			FOC1060			
190 - DS11 Repotenciado		FA1185	FO171	FOC73/1		FO346	H
190 E / F / H - 8210 Importado	12/85-	FA4650/1	FO339			FO346 FA840	H ES
190 E / F / H - 8210 Nacional	12/85-	FA4650/1	FO339	FOC72/2		FO346 FA840	H ES
190 H - 8210 Nacional Turbo	01/82-12/85	FA9835	FO339	FOC72/2		FO346 FA860	H ES
200-Serie							
210 - FNM	01/63-12/75			FOC1060			
210 S - 8210 Importado	12/85-			FOC480/1		FO346	H
210 S - 8210 Nacional	12/85-	FA4650/1	FO339	FOC72/2		FO346	H
70-Serie							
70 - CO 3 Nacional				FOC72/2			
D 11000							
D 11000 - FNM	01/63-12/75			FOC1060			

FORD

CAMINHÕES

MODELO/ MOTOR		ar	óleo	combustível	cabine	diversos	tipo filtro
Serie B							
B 12000 - MWM 6.10	01/96-	FA5460	FO339	FOC72/2			
B 1618 - MWM 6.10	01/92-12/97	FA9834	FO339	FOC72/2		FA820	ES
B 1621 - MWM 6.10				FOC460/1			
Serie FB							
4000 - Ford Diesel	01/80-12/89	FA7996	FO900			FO346 FA805	H ES
Parcialmente/ou - Com Carcaça MANN-FILTER		FA7108					
FB 4000 - Ford Diesel	01/90-		FO900			FO346	H
Serie F							
F 11000 - Perkins 6.357	01/81-01/82					FO346	H
Separador de água				FOC530/1			
F 11000 - MWM D229/6	01/81- -01/99 02/99-	FA2710	FO962	FOC1059 FOC72/2		FO346 FA810	H ES
F 11000 - Perkins 6.358	01/82-	FA2710	FO675			FO346 FA810	H ES
Separador de água				FOC530/1			
F 12000 - MWM D229/6	01/81-	FA2710	FO962	FOC1059		FO346 FA810	H ES
Separador de água				FOC530/1			
F 12000 - Perkins 6.357	01/81-			FOC530/1		FO346	H
Separador de água				FOC530/1			
F 12000 - Perkins 6.358	01/82-	FA2710	FO675	FOC530/1		FO346 FA810	H ES
F 12000 - MWM 6.10	04/92-	FA7998	FO339			FO346 FA820	H ES
Separador de água				FOC530/1			
F 12000 - MWM D229/6	04/92-	FA7998	FO962			FO346 FA820	H ES
Pré-filtro				FOC1059			
Separador de água				FOC530/1			
F 12000 - 5.9 - Cummins 6BTAA	01/99-			FOC72/2		FO346 FRA33	H Refr.



Linha de produtos Magneti Marelli
Filtro ar, óleo, cabine e combustível



MODELO/ MOTOR		ar	óleo	combustível	cabine	diversos	tipo filtro

FORD (cont.)

CAMINHÕES							
Serie F							
F 12000 - 5.9 - Cummins 6BTAA	01/99-		FO280				
Filtro blindado - Até 15000km							
Separador de água				FOC410			
F 13000 - MWM D229/6	01/81-	FA2710	FO962	FOC1059		FO346 FA810	H ES
Separador de água				FOC530/1			
F 13000 - Perkins 6.357	01/81-			FOC530/1		FO346	H
F 13000 - Perkins 6.358	01/82-	FA2710	FO675			FO346 FA810	H ES
Separador de água				FOC530/1			
F 14000 - MWM D229/6	01/81-	FA2710	FO962	FOC1059		FO346 FA810	H ES
Separador de água				FOC530/1			
F 14000 - MWM 6.10	04/92-	FA7998	FO339			FO346 FA820	H ES
Separador de água				FOC530/1			
F 14000 - 5.9 - Cummins 6BTAA	01/99-			FOC72/2		FO346 FRA33	H Refr.
Filtro blindado - Até 15000km			FO280				
Separador de água				FOC410			
F 16000 - 5.9 - Cummins 6BT	01/99-			FOC72/2		FO346 FRA33	H Refr.
Filtro blindado - Até 15000km			FO280				
Separador de água				FOC410			
F 19000 - MWM D229/6	01/81-	FA2710	FO962	FOC1059		FO346 FA810	H ES
Separador de água				FOC530/1			
F 21000 - MWM D229/6	01/81-	FA2710	FO962	FOC1059		FO346 FA810	H ES
Separador de água				FOC530/1			
F 22000 - MWM D229/6	01/81-	FA2710	FO962	FOC1059		FO346 FA810	H ES
Separador de água				FOC530/1			
Serie FT							
FT 6000 - MWM D229/6	01/80-12/81	FA9834 FA2710	FO962			FO346	H
Alguns modelos							
Pré-filtro				FOC1059			
FT 7000 - Detroit 4.53N	01/77-12/79	FA9834				FA820	ES
FT 7000 - MWM D229/6	01/80-12/81	FA9834 FA2710	FO962			FO346	H
Alguns modelos							
Pré-filtro				FOC1059			
FT 8000 - Detroit 6.53N	01/77-12/79	FA4440				FA830	ES
FT 8500 - Detroit 6.53N	01/77-12/79	FA4440				FA830	ES
Serie 7							
712 E - Cummins Int. 4 ISBE	06/07-	FA7998				FO346	H
Serie 8							
814 - 3.9 - Cummins 4B	05/96-	FA7998				FO346 FA820	H ES
	03/01-			FOC72/2			
815 E - 3.9 - Cummins Int. 4 ISBE	02/05-	FA7998				FO346 FA820	H ES
815 S - 3.9 - Cummins 4B	05/96-	FA7998					
	03/01-			FOC72/2		FO346 FA820	H ES

CB - Câmbio
DH - Direção hidráulica
ES - Elemento de segurança

FAS - Filtro do ar seco
FC - Filtro do ar para cabine
H - Hidráulico

PC - Precarga
TR - Transmissão hidráulica
Refr. - Filtro de refrigeração

filtro

153



MODELO/ MOTOR		ar	óleo	combustível	cabine	diversos	tipo filtro
							

FORD (cont.)

CAMINHÕES

Serie 9 915 - 3.9 - Cummins 4B	09/02-	FA7998		FOC72/2		FO346 FA820	H ES
Serie 10 1030 - 8.3 - Cummins 6CT Separador de água	01/92-	FA5461		FOC72/2 FOC410 FOC530/1		FO346 FRA33	H Refr.
Serie 11 1113 - MWM D229/6 Separador de água	-12/86	FA5460	FO962	FOC1059 FOC530/1		FO346	H
1117 - 6.6 - Ford FTO Separador de água	-12/86	FA5460		FOC72/2 FOC530/1		FO346	H
1117 - 6.6 - Ford FTO T Separador de água	01/87-	FA5460		FOC72/2 FOC530/1		FO346	H
Serie 12 1215 - 6.6 - Ford FTO Separador de água	07/91-04/92	FA5460		FOC72/2 FOC530/1		FO346	H
1215 - 5.9 - Cummins 6B Separador de água	05/92- -01/99	FA5460	FO280	FOC72/2 FOC410 FOC530/1		FO346 FRA33	H Refr.
1217 - 5.9 - Cummins 6B Filtro blindado - Até 15000km Separador de água	04/92- -01/99	FA5460	FO280	FOC72/2 FOC410 FOC530/1		FO346 FRA33	H Refr.
1218 - 6.6 - Ford FTO T Separador de água	12/86-	FA5460		FOC72/2 FOC530/1		FO346	H
Serie 13 1313 - MWM D229/6 Separador de água	01/86-	FA5460		FOC1059 FOC530/1		FO346	H
1314 - 6.6 - Ford FTO Separador de água	12/86-	FA5460		FOC72/2 FOC530/1		FO346	H
1317 - 6.6 - Ford FTO Separador de água	12/86-	FA5460		FOC72/2 FOC530/1		FO346	H
1317 - 5.9 - Cummins 6B Filtro blindado - Até 15000km	09/02-		FO280	FOC72/2		FO346	H
1317 E - 3.9 - Cummins Int. 4 ISBE	02/05-					FO346	H
Serie 14 1415 - 6.6 - Ford FTO Separador de água	12/86-	FA5460		FOC72/2 FOC530/1		FO346	H
1415 - 5.9 - Cummins 6BTAA Filtro blindado - Até 15000km Separador de água	04/92- -11/01 -01/99	FA5460	FO280	FOC72/2 FOC410 FOC530/1		FO346 FRA33	H Refr.
1417 - 5.9 - Cummins 6BT Filtro blindado - Até 15000km Separador de água	04/92- -08/02 -01/99	FA5461	FO280	FOC72/2 FOC410 FOC530/1		FO346 FRA33	H Refr.
1418 - 6.6 - Ford FTO T Separador de água	12/86-	FA5460		FOC72/2 FOC530/1		FO346	H



Linha de produtos Magneti Marelli
Filtro ar, óleo, cabine e combustível



MODELO/ MOTOR		ar	óleo	combustível	cabine	diversos	tipo filtro

FORD (cont.)

CAMINHÕES

Serie 14

1419 - 6.6 - Ford FTO T Separador de água	12/86-	FA5460		FOC72/2 FOC530/1		FO346	H
1421 - 5.9 - Cummins 6BTAA	12/99-			FOC72/2		FO346 FRA33	H Refr.
Filtro blindado - Até 15000km	-08/02	FA5461	FO280				
1422 - 8.3 - Cummins 6CT	01/92-			FOC72/2		FO346 FRA33	H Refr.
	-08/02	FA5461					
	09/02-	FA9839					
	-01/99			FOC410			
	09/02-					FA839	ES
Separador de água	-01/99			FOC530/1			
Serie 15							
1517 - Ford FTO	-12/87	FA5460		FOC72/2		FO346	H
1513 - MWM 229/6	01/86-	FA5460	FO962	FOC1059		FO346	H
1514 - 6.6 - Ford FTO T Separador de água	12/86-	FA5460		FOC72/2 FOC530/1		FO346	H
1517 - 5.9 - Cummins 6BTAA	11/02-			FOC72/2		FO346 FRA33	H Refr.
Filtro blindado - Até 15000km			FO280				
1517 E - 3.9 - Cummins Int. 4 ISBE	02/05-					FO346	H
1521 - 5.9 - Cummins 6BTAA	12/01-			FOC72/2		FO346 FRA33	H Refr.
Filtro blindado - Até 15000km			FO280				
Serie 16							
1615 - 6.6 - Ford FTO Separador de água	12/86- -01/99	FA5460		FOC72/2 FOC530/1		FO346	H
1617 - 8.3 - Cummins 6CT	09/91-			FOC72/2		FO346 FRA33	H Refr.
	-08/02	FA5460					
	09/02-	FA9839				FA839	ES
	-01/99			FOC410 FOC530/1			
Separador de água							
1617 - 5.9 - Cummins 6BT	05/93-			FOC72/2		FO346 FRA33	H Refr.
	-11/01	FA5460					
	-01/99		FO280	FOC410			
Filtro blindado - Até 15000km			FO280				
Separador de água				FOC530/1			
1618 - 6.6 - Ford FTO T Separador de água	11/86-	FA5460		FOC72/2 FOC530/1		FO346	H
1618 - MWM 6.10 Separador de água	01/92-	FA5460	FO339	FOC72/2 FOC530/1		FO346	H
1619 - 6.6 - Ford FTO T Separador de água	12/86-	FA5460		FOC72/2 FOC530/1		FO346	H
1621 - 5.9 - Cummins 6BTAA	12/99-			FOC72/2		FO346 FRA33	H Refr.
	-11/01	FA5460					
Filtro blindado - Até 15000km			FO280				
1622 - 8.3 - Cummins 6CTA	09/91-			FOC72/2		FO346 FRA33	H Refr.
	-12/01	FA5461					
	01/99			FOC410			
	01/02-	FA9839				FA839	ES
Separador de água	-01/99			FOC530/1			

CB - Câmbio
DH - Direção hidráulica
ES - Elemento de segurança

FAS - Filtro do ar seco
FC - Filtro do ar para cabine
H - Hidráulico

PC - Precarga
TR - Transmissão hidráulica
Refr. - Filtro de refrigeração



MODELO/ MOTOR		ar	óleo	combustível	cabine	diversos	tipo filtro
							

FORD (cont.)

CAMINHÕES

Serie 17

1717 - 5.9 - Cummins 6BTAA

08/02-

FOC72/2

FO346

H

FRA33

Refr.

Filtro blindado - Até 15000km

FO280

1717 E - 3.9 - Cummins Int. 4 ISBE

02/05-

FO346

H

1721 - 5.9 - Cummins 6BTAA

12/99-

FOC72/2

FO346

H

FRA33

Refr.

Filtro blindado - Até 15000km

FO280

-11/01

FA5460

1722 - 5.9 - Cummins 6BTAA

12/01-12/06

FOC72/2

FO346

H

FRA33

Refr.

Filtro blindado - Até 15000km

FO280

1722 E - 5.9 - Cummins Int. 6 ISBE

01/06-

FA9839

FO346

H

FA839

ES

1722 MAX TON - 8.3 - Cummins 6CTAA

01/01-

FA9839

FOC72/2

FO346

H

FA839

ES

1731 MAX TON - 8.3 - Cummins 6CTAA

01/01-

FA9839

FOC72/2

FO346

H

FA839

ES

Serie 22

2218 - 6.6 - Ford FTO T

12/86-

FA5460

FOC72/2

FO346

H

Separador de água

FOC530/1

Serie 23

2319 - 6.6 - Ford FTO T

12/86-

FA5460

FOC72/2

FO346

H

-01/99

FOC530/1

2322 - 8.3 - Cummins 6CT

09/91-

FA5460

FOC72/2

FO346

H

FRA33

Refr.

-01/99

FOC410

Serie 24

2421 - 5.9 - Cummins 6BTAA

01/05-01/06

FA9839

FOC72/2

FO346

H

FA839

ES

FRA33

Refr.

Filtro blindado - Até 15000km

FO280

2421 - 5.9 - Cummins 6BTAA

-12/04

FA9839

FOC72/2

FO346

H

FA839

ES

FRA33

Refr.

Filtro blindado - Até 15000km

FO280

2422 - 8.3 - Cummins 6CTAA

09/91-01/06

FOC72/2

FO346

H

-11/01

FA5460

12/01-

FA9839

-01/99

FOC410

FOC530/1

Separador de água

2422 E - 5.9 - Cummins Int. 6 ISBE

01/06-

FA9839

FO346

H

FA839

ES

2422 MAX TON - 8.3 - Cummins 6CTAA

11/03-

FA9839

FOC72/2

FO346

H

FA839

ES

2425 - 8.3 - Cummins 6TCAA

01/96-

FOC72/2

FO346

H

-11/01

FA5460

12/01-

FA9839

-01/99

FOC410

FOC530/1

Separador de água

2428 E - 5.9 - Cummins Int. 6 ISBE

01/06-

FA9839

FO346

H

FA839

ES

Serie 26

2622 E - 5.9 - Cummins Int. 6 ISBE

01/06-

FA9839

FO346

H

FA839

ES



Linha de produtos Magneti Marelli
Filtro ar, óleo, cabine e combustível



MODELO/ MOTOR		ar	óleo	combustível	cabine	diversos	tipo filtro

FORD (cont.)

CAMINHÕES

Serie 26

2622 MAX TON - 8.3 - Cummins 6CTAA

09/91-01/06

FOC72/2

FO346

H

-11/01

FA5460

12/01-

FA9839

FA839

ES

Separador de água

-01/99

FOC530/1

2626 - 8.3 - Cummins 6CTAA

01/93-01/06

FOC72/2

FO346

H

-11/01

FA5460

12/01-

FA9839

FA839

ES

-01/99

FOC410

FOC530/1

Separador de água

2628 E - 5.9 - Cummins Int. 6 ISBE

01/06-

FA9839

FO346

H

FA839

ES

2630 - 8.3 - Cummins 6CTAA

06/97-

FOC72/2

FO346

H

-11/01

FA5460

12/01-

FA9839

FA839

ES

-01/99

FOC410

FOC530/1

Separador de água

2631 MAX TON - 8.3 - Cummins 6CTAA

06/97-12/06

FOC72/2

FO346

H

-11/01

FA5460

12/01-

FA9839

FA839

ES

-01/99

FOC530/1

Separador de água

2632 E - 8.3 - Cummins ISCE

02/06-

FA9839

FO346

H

FA839

ES

Serie 28

2831 - 8.3 - Cummins 6CTAA

05/05-12/06

FOC72/2

FO346

H

FA839

ES

Serie 29

2932 E - 8.3 - Cummins ISCE

02/06-

FA9839

FO346

H

FA839

ES

Serie 32

3222 MAX TON - 8.3 - Cummins 6CTAA

01/02-01/06

FOC72/2

FO346

H

FA839

ES

3224 - 8.3 - Cummins 6CTAA

07/92-

FOC72/2

FO346

H

-11/01

FA5460

12/01-

FA9839

FA839

ES

-06/97

FOC530/1

Separador de água

3224 TAC - 7.8 Intercooler - Ford

01/89-12/89

FA5461

FOC72/2

FO346

H

Separador de água

FOC530/1

Serie 35

3530 - 8.3 - Cummins 6CTAA

11/91-

FA5461

FOC72/2

FO346

H

FOC410

FRA33

Refr.

Separador de água

FOC530/1

Serie 40

4030 - 8.3 - Cummins 6CT

09/95-

FA5461

FOC72/2

FO346

H

FRA33

Refr.

-01/99

FOC410

Separador de água

FOC530/1

4030 MAX TON - 8.3 - Cummins 6CTAA

01/02-

FA9839

FOC72/2

FO346

H

FA839

ES

4031 - 8.3 - Cummins 6CT

09/95-01/06

FA5461

FOC72/2

FO346

H

FRA33

Refr.

-01/99

FOC410

Separador de água

FOC530/1

Separador de água

FOC530/1

CB - Câmbio
DH - Direção hidráulica
ES - Elemento de segurança

FAS - Filtro do ar seco
FC - Filtro do ar para cabine
H - Hidráulico

PC - Precarga
TR - Transmissão hidráulica
Refr. - Filtro de refrigeração

filtro

157



MODELO/ MOTOR		ar	óleo	combustível	cabine	diversos	tipo filtro
							

FORD (cont.)

CAMINHÕES

Serie 40

4031 MAX TON - 8.3 - Cummins 6CTAA

01/02-01/06

FA9839

FOC72/2

FO346
FA839

H
ES

Serie 43

4331 - 8.3 - Cummins 6CTAA

02/03-12/06

FA9839

FOC72/2

FO346
FA839

H
ES

Serie 44

4432 E - 8.3 - Cummins ISCE

02/06-04/07

FA9839

FO346
FA839

H
ES

Serie 45

4532 E - MaxTon - Cummins ISCE 8.3

04/07-

FA9839

FO346
FA839

H
ES

Serie 50

5031 - 8.3 - Cummins 6CTAA

05/05-12/06

FA9839

FOC72/2

FO346
FA839

H
ES

5032 E - 8.3 - Cummins ISCE

02/06-

FA9839

FO346
FA839

H
ES

Serie 63

6332E - 6x4 - Cummins ISC 320 P5

06/08-

FA9839

FO346
FA839

H
ES

4600

4600 - Ford Diesel

01/78-12/84

FO900

5600

5600 - Ford Diesel

01/78-12/84

FO900

6600

6600 - Ford Diesel

01/78-12/84

FO900

ÔNIBUS

Serie B

B12000 - MWM 6.10 T

01/96-

FA5460

FO339

FOC72/2

B1618 - MWM 6.10 TCA

01/92-

FO339

Separador de água

-01/98

FOC72/2

Separador de água

02/98-

FOC460/1

B1621 - MWM 6.10 TCA

01/92-

FO339

Separador de água

-01/98

FOC72/2

Separador de água

02/98-

FOC460/1

GENERAL MOTORS

Serie 5

5.90 - Isuzu 4JG2

01/98-

FO346

H

Serie 6

6100 - 4.1 - Maxion S4

01/97-

FO900

FO346

H

Separador de água

FOC530/1

6150 - 4.2 - MWM Sprint 6

01/97-

FO962

FO346

H

Separador de água

FOC530/1

Serie 12

12170 - 6.6 - Caterpillar 3116

01/96-12/02

FO346

H

Separador de água

FOC470/1

Serie 14

14000 - GM 4.8 6Cil. Alc/Gas

01/85-

FA2710

FO346
FA810

H
ES

14000 - Perkins 6.354 Diesel

01/85-

FA9834

FO675

FOC530/1

FO346
FA820

H
ES



Linha de produtos Magneti Marelli
Filtro ar, óleo, cabine e combustível



MODELO/ MOTOR		ar	óleo	combustível	cabine	diversos	tipo filtro

GENERAL MOTORS (cont.)

Serie 14 14190 - 6.6 - Caterpillar 3116 Separador de água	01/96-12/02			FOC470/1		FO346	H
Serie 15 15190 - 6.6 - Caterpillar 3116 Separador de água	01/97-			FOC470/1		FO346	H
Serie 16 16220 - 6.6 - Caterpillar 3116 Separador de água	01/96-12/02			FOC470/1		FO346	H

IVECO

Tector 170E25 - Tector 6 cilindros Separador de água	01/09-	FA9837		FOC460/1		FA837	ES
170E25T - Tector 6 cilindros Separador de água	01/09-	FA9837		FOC460/1		FA837	ES
240E25 - Tector 6 cilindros Separador de água	01/09-	FA9837		FOC460/1		FA837	ES
240E25S - Tector 6 cilindros Separador de água	01/09-	FA9837		FOC460/1		FA837	ES
260E25 - Tector 6 cilindros Separador de água	01/09-	FA9837		FOC460/1		FA837	ES
EuroCargo (BR) 120E15 - Iveco 8060.25V Separador de água	01/99-	FA4440		FOC1085		FO346 FA830	H ES
150E18 - Iveco 8060.25V Separador de água	09/91-	FA4440		FOC1085		FO346 FA830	H ES
160E21 - Iveco 8060.45V Separador de água	01/98- -05/06 06/06-	FA4440 FA9837		FOC460/1		FO346 FA830 FA837	H ES ES
170E21 - MWM 6.10TCA Separador de água	01/04- -05/06 06/06-	FA4440 FA9837				FO346 FA830 FA837	H ES ES
170E22 TECTOR - TECTOR F4AE0681D Separador de água	01/04- -05/06 06/06-	FA4440 FA9837		FOC460/1		FO346 FA830 FA837	H ES ES
230E22 TECTOR - TECTOR F4AE0681D Separador de água	01/05- -05/06 06/06-	FA4440 FA9837		FOC460/1		FO346 FA830 FA837	H ES ES
230E24 TECTOR - TECTOR F4AE0681D Separador de água	01/05- -05/06 06/06-	FA4440 FA9837		FOC460/1		FO346 FA830 FA837	H ES ES
450E32T - Cavallino - CURSOR 8 7.8L Separador de água	11/06-	FA9837		FOC1085		FA837	ES
EuroTech (BR) 450E37T - 8210-42K Separador de água	01/99-	FA9835		FOC1085		FO346 FA860	H ES

CB - Câmbio
DH - Direção hidráulica
ES - Elemento de segurança

FAS - Filtro do ar seco
FC - Filtro do ar para cabine
H - Hidráulico

PC - Precarga
TR - Transmissão hidráulica
Refr. - Filtro de refrigeração



MODELO/ MOTOR		ar 	óleo 	combustível 	cabine 	diversos 	tipo filtro
---------------	---	---	---	--	---	---	-------------

IVECO (cont.)

EuroTrakker (BR)							
380E37H - 8210-42K	01/04-					FO346	H
Separador de água				FOC1085			
380T38 - CURSOR 13 F3BE0681G	01/04-					FO346	H
Separador de água				FOC1085			
450E37T - 8210-42K	01/98-	FA9835				FO346 FA860	H ES
Separador de água				FOC1085			
720 E 42HT - CURSOR 13 F3BE0681G	05/06-					FO346	H
Separador de água				FOC1085			
Stralis (BR)							
HD 380 - CURSOR 13 F3BE0681G	08/05-					FO346	H
Separador de água				FOC1085			
HD 450 E38 - CURSOR 13 F3BE0681G	08/05-					FO346	H
Separador de água				FOC1085			
HD 450 S38T - CURSOR 13 F3BE0681G	08/05-					FO346	H
Separador de água				FOC1085			
HD 450 S42T - CURSOR 13 F3BE0681V	08/05-					FO346	H
Separador de água				FOC1085			
HD 490 S 38T - CURSOR 13	01/08-					FO346	H
Separador de água				FOC1085			
HD 490 S 42T - CURSOR 13	01/08-					FO346	H
Separador de água				FOC1085			
HD 570 S38T - CURSOR 13 F3BE0681G	08/05-					FO346	H
Separador de água				FOC1085			
HD 570 S42T - CURSOR 13 F3BE0681V	08/05-					FO346	H
Separador de água				FOC1085			
HD 740 S42T - CURSOR 13 F3BE0681V	08/05-					FO346	H
Separador de água				FOC1085			

MAFERSA

ÔNIBUS							
M-Serie							
M 210S - Cummins 6CT 8.3		FA4440		FOC72/2		FA830 FRA33	ES Refr.
Pré-filtro				FOC410			

MATRA

CAMINHÕES							
Matra							
Matra - MWM D229/4		FA9834	FO123	FOC1059		FA820	ES
Matra - MWM D229/6		FA9834	FO962	FOC1059		FA820	ES

MERCEDES-BENZ

CAMINHÕES							
Accelo (BR)							
715 C - OM 612-LA	01/02-	FA9838				FO346	H
Separador de água	-04/07			FOC480/1			
915 C - OM-904 LA	01/02-	FA9838				FO346	H
Separador de água	-04/07			FOC480/1			
Atego II (970, 972, 974) 04-							
1315 - OM 904 LA	01/05-					FO346	H
Separador de água	-04/07			FOC480/1			
1418 - OM 904 LA	01/05-					FO346	H
Separador de água	-04/07			FOC480/1			



Linha de produtos Magneti Marelli
Filtro ar, óleo, cabine e combustível



MODELO/ MOTOR		ar	óleo	combustível	cabine	diversos	tipo filtro

MERCEDES-BENZ (cont.)

CAMINHÕES

Atego II (970, 972, 974) 04-

1518 - OM 904 LA	01/05-					FO346	H
Separador de água	-04/07			FOC480/1			
1718 - OM 904 LA	01/05-					FO346	H
Separador de água	-04/07			FOC480/1			
1725 - OM 906 LA	01/05-					FO346	H
Separador de água	-04/07			FOC480/1			
1728 - OM 926 LA	07/07-					FO346	H
2425 - OM 906 LA	01/05-					FO346	H
Separador de água	-04/07			FOC480/1			
2428 - OM 926 LA	07/07-					FO346	H
Axor (BR)							
1933 S - OM 926 LA	01/05-					FO346	H
Separador de água	-04/07			FOC480/1			
2035 S - OM 457 LA	01/05-					FO346 FA1163	H ES
Elemento filtrante - conforme original 4760940004		FA9840					
Separador de água				FOC480/1			
2040 S - OM 457 LA	01/05-					FO346 FA1163	H ES
Elemento filtrante - conforme original 4760940004		FA9840					
Separador de água				FOC480/1			
2044 S - OM 457 LA	01/06-					FO346 FA1163	H ES
Elemento filtrante - conforme original 4760940004		FA9840					
Separador de água				FOC480/1			
2533 - 6x2 - OM 926 LA	01/05-					FO346	H
Separador de água				FOC480/1			
2540 S - 6x2 - OM 457 LA	01/05-					FO346 FA1163	H ES
Elemento filtrante - conforme original 4760940004		FA9840					
Separador de água				FOC480/1			
2544 S - 6x2 - OM 457 LA	01/06-					FO346 FA1163	H ES
Elemento filtrante - conforme original 4760940004		FA9840					
Separador de água				FOC480/1			
2640 S - 6x4 - OM 457 LA	01/06-					FO346 FA1163	H ES
Elemento filtrante - conforme original 4760940004		FA9840					
Separador de água				FOC480/1			
2644 S - 6x4 - OM 457 LA	01/05-					FO346 FA1163	H ES
Elemento filtrante - conforme original 4760940004		FA9840					
Separador de água				FOC480/1			
2826 - 6x4 - OM 926 LA	01/06-					FO346	H
Separador de água				FOC480/1			
2831 - 6x4 - OM 926 LA	01/06-					FO346	H
Separador de água				FOC480/1			
3340 / 3340 S / 3340 K - 6x4 - OM 457 LA	01/05-					FO346 FA1163	H ES
Elemento filtrante - conforme original 4760940004		FA9840					
Separador de água				FOC480/1			
3344 / 3344 S / 3344 K - 6x4 - OM 457 LA	01/06-					FO346 FA1163	H ES
Elemento filtrante - conforme original 4760940004		FA9840					

CB - Câmbio
DH - Direção hidráulica
ES - Elemento de segurança

FAS - Filtro do ar seco
FC - Filtro do ar para cabine
H - Hidráulico

PC - Precarga
TR - Transmissão hidráulica
Refr. - Filtro de refrigeração



MODELO/ MOTOR		ar	óleo	combustível	cabine	diversos	tipo filtro
							

MERCEDES-BENZ (cont.)

CAMINHÕES

Axor (BR)

3344 / 3344 S / 3344 K - 6x4 - OM 457 LA

Separador de água

01/06-

FOC480/1

4140 K - 6x4 - OM 457 LA

01/06-

FO346
FA1163

H
ES

Elemento filtrante - conforme original 4760940004

Separador de água

FA9840

FOC480/1

4144 K - 6x4 - OM 457 LA

01/06-

FO346
FA1163

H
ES

Elemento filtrante - conforme original 4760940004

Separador de água

FA9840

FOC480/1

6t-Serie

608 D - OM 314

Separador de água

01/93-

FA8528

FO442

FOC1059

FO346

H

608 L - D / E / O - OM 314

Pré-filtro

Separador de água

01/73-12/83

FA8528

FOC530/1

FO346

H

610 L - OM 314 Álcool

01/85-

FA8528

FO442

FOC530/1

FO346

H

7t-Serie

708 L - D - OM 314

Separador de água

01/83-

FA7998

FO364

FOC1058

FO346

H

708 L - E - OM 314

Pré-filtro

Separador de água

01/73-12/82

FA7998

FOC530/1

FO346

H

709 L - OM 364

01/89-

FA7108

FO364

FOC1059

FO346

H

710 Plus - OM 364LA

Separador de água

01/95-

FA7998

FO364

FOC530/1

FO346

H

A partir do chassi n°: 339846

Separador de água

-09/06

FA7998

FOC1058

FA820

ES

Separador de água

01/00-

FA2710

FOC530/1

FA810

ES

710 (4x2) - OM 364A

Separador de água

-12/99

FA7998

FOC530/1

FA820

ES

712 C - OM 904LA

Separador de água

01/96-

FA7998

FO364

FOC1058

FO346

H

712 E - OM 364 LA

Separador de água

10/06-05/07

FA7998

FOC480/1

FOC480/1

ES

Separador de água

01/98-

FA9838

FOC480

FO346

H

Separador de água

-11/04

FA7998

FOC480/1

FO346

H

Separador de água

12/04-

FA7998

FOC1058

FA820

ES

A partir do chassi n°: 339846

Separador de água

-09/06

FA2710

FOC530/1

FA810

ES

Separador de água

10/06-

FA7998

FOC480/1

FOC480/1

ES

8t-Serie

812 L - OM 364 A/LA

Separador de água

01/90-

FA7998

FO364

FOC1058

FO346

H

813 D - OM 364 A/LA

Separador de água

01/90-

FA7998

FO364

FOC1058

FO346

H

Separador de água

01/90-

FA7998

FOC530/1

FA820

ES

Separador de água

01/90-

FA7998

FOC530/1

FOC530/1

ES



Linha de produtos Magneti Marelli
Filtro ar, óleo, cabine e combustível



MODELO/ MOTOR		ar	óleo	combustível	cabine	diversos	tipo filtro

MERCEDES-BENZ (cont.)

CAMINHÕES

9t-Serie

912 C - OM 904 LA	01/00-	FA9838				FO346	H
Separador de água	-11/04			FOC480			
Separador de água	12/04-			FOC480/1			
912 L - OM 364 A/LA	01/90-		FO364	FOC1058		FO346	H
	-12/99	FA7998				FA820	ES
	01/00-	FA2710				FA810	ES
Separador de água				FOC530/1			
914 C - OM 904 LA	01/98-	FA9838				FO346	H
Separador de água				FOC480			
914 L - OM 356 A	01/90-	FA7998	FO364	FOC1058		FO346	H
						FA820	ES
Separador de água				FOC530/1			
915 E - OM 904 LA	01/98-	FA9838				FO346	H
Separador de água	-11/04			FOC480			
Separador de água	12/04-			FOC480/1			

10t-Serie

1014 LN - OM 364 LA	01/89-	FA7998	FO364	FOC1058		FO346	H
						FA820	ES
Separador de água				FOC530/1			
1017 O - OM 366 LA	01/90-	FA9834	FO301	FOC1058		FO346	H
						FA820	ES

11t-Serie

1113 L - OM 352	-12/78	FA9834				FO346	H
						FA820	ES
Pré-filtro				FOC1059			
1113 L/LK - OM 352	12/78-	FA9834		FOC1058		FO346	H
						FA820	ES
	01/79-		FO519				
1114 L/LK - OM 352	12/78-	FA9834		FOC1058		FO346	H
						FA820	ES
	01/79-		FO519				
1116 - OM 352A	01/79-	FA9834		FOC1058		FO346	H
						FA820	ES
1118 L/LK - OM 352	12/78-	FA9834		FOC1058		FO346	H
						FA820	ES
	01/79-		FO519				

12t-Serie

1214 C - OM 364 A/LA	12/96-	FA7998	FO364	FOC1058		FO346	H
						FA820	ES
Separador de água				FOC530/1			
1214 L/LK/K/R/LA - OM 366 A/LA	01/89-			FOC1059		FO346	H
	01/96-	FA9836	FO301				
	-12/95	FA9834	FO366			FA820	ES
Separador de água				FOC530/1			
Separador de água	01/96-			FOC460/1			
1214 L/LK/K/R/LA - OM 366	01/89-	FA9834	FO519	FOC1059		FO346	H
						FA820	ES
Separador de água				FOC530/1			
1215 C - OM 904 LA	01/98-	FA9838				FO346	H
						FA820	ES
Separador de água	-10/04			FOC480			
Separador de água	12/04-			FOC480/1			

CB - Câmbio
DH - Direção hidráulica
ES - Elemento de segurança

FAS - Filtro do ar seco
FC - Filtro do ar para cabine
H - Hidráulico

PC - Precarga
TR - Transmissão hidráulica
Refr. - Filtro de refrigeração



MODELO/ MOTOR

ar



óleo



combustível



cabine



diversos



tipo filtro

MERCEDES-BENZ (cont.)

CAMINHÕES

12t-Serie

1215 L/LA - OM 904 LA

-12/97

FOC1059

FO346

H

-12/95

FO366

01/96-

FO301

FA820

ES

FA9834

Separador de água

-12/95

FOC530/1

Separador de água

01/96-

FOC460/1

1218 - Eletrônico - OM 904 LA

01/01-

FA9838

FO346

H

Separador de água

-06/07

FOC480/1

1218 L/LA/LAK/LK-R - OM 366 A/LA

01/89-

FOC1059

FO346

H

01/96-

FA9836

FO301

-12/95

FA9834

FO366

FA820

ES

Separador de água

01/96-

FOC530/1

Separador de água

01/96-

FOC460/1

13t-Serie

1313 L/LK - OM 352

01/79-

FA9834

FO519

FOC1058

FO346

H

FA820

ES

1314 L/LK/LAK - OM 352

01/79-

FA9834

FO519

FOC1058

FO346

H

FA820

ES

1316 L/LK - OM 352

01/79-

FA9834

FO519

FOC1058

FO346

H

FA820

ES

1317 L/LK/LAK - OM 352A

01/75-

FA9834

FOC1058

FO346

H

FA820

ES

1318 - OM 904 LA

01/03-

FA9836

FO346

H

Separador de água

-11/04

FOC480

Separador de água

12/04-

FOC480/1

1318 L/LK - OM 352 A

01/75-

FA9834

FOC1058

FO346

H

FA820

ES

1319 L - OM 366 A/LA

01/84-

FA9834

FO366

FOC1059

FO346

H

FA820

ES

Separador de água

01/96-

FOC530/1

14t-Serie

1414 L - OM 366

01/89-

FA9834

FO519

FOC1059

FO346

H

FA820

ES

Separador de água

01/89-

FA9834

FOC1059

1414 L/LK - OM 366 A/LA

01/89-

FA9834

FOC1059

FO346

H

FA820

ES

-12/95

FO366

01/96-

FO301

FOC530/1

Separador de água

01/02-

FA9836

FO346

H

1418 L/EL - OM 904 LA

-11/04

FOC480

Separador de água

12/04-

FOC480/1

1418 L/LK/LA/LAK-R - OM 366 A/LA

01/89-

FOC1059

FO346

H

01/96-

FA9836

FO301

-12/95

FA9834

FO366

FA820

ES

Separador de água

01/96-

FOC530/1

Separador de água

01/96-

FOC460/1

1420 - OM 366 LA

01/02-

FA9836

FO366

Separador de água

01/96-

FOC460/1

15t-Serie

1513 L/LK - OM 352

01/79-

FA9834

FO519

FOC1058

FA820

ES

1514 L/LK - OM 352

01/79-

FA9834

FO519

FOC1058

FA820

ES

1516 L/LK - OM 352

01/79-

FA9834

FO519

FOC1058

FA820

ES



Linha de produtos Magneti Marelli
Filtro ar, óleo, cabine e combustível



MODELO/ MOTOR		ar	óleo	combustível	cabine	diversos	tipo filtro

MERCEDES-BENZ (cont.)

CAMINHÕES

15t-Serie

1517 L/LK - OM 355/5	01/86-	FA9834	FO345	FOC1060		FA820	ES
1518 L/LK - OM 352 A	01/87-	FA9834	FO519	FOC1058		FA820	ES
1519 L - Canavieiro - OM 355/5	01/80-	FA4440	FO345	FOC1060		FA830	ES
1519 L/LS/LK - OM 355/5	01/80-	FA9834	FO345	FOC1060		FA820	ES
1520 L - Canavieiro - OM 355/5	01/80-	FA4440	FO345	FOC1060		FA830	ES
1520 LP - OM 352	01/87-	FA9834	FO519	FOC1058		FA820	ES
1524 LS - OM 355/6	01/85-11/87	FA4440	FO345	FOC1060		FA830	ES
Separador de água				FOC530/1			
1525 LS - OM 355/6	01/85-12/88	FA4440	FO345	FOC1060		FA830	ES
Separador de água				FOC530/1			

16t-Serie

1614 L/LK - OM 366	01/89-	FA9834	FO519	FOC1058		FA820	ES
Separador de água				FOC480			
1618 L/LK - OM 366 A/LA	01/89-	FA9834	FO301	FOC1058		FA820	ES
Separador de água				FOC530/1			
1618 M - OM 904 LA	01/98-	FA7998					
Separador de água	-11/04			FOC480			
Separador de água	12/04-			FOC480/1			
1620 L - OM 906 LA	01/98-					FO346	H
	-10/06	FA9836					
	11/06-	FA9837				FA837	ES
Separador de água	-11/04			FOC480			
Separador de água	12/04-			FOC480/1			
1620 L/LK - OM 366 LA	01/96-	FA9836	FO301				
Separador de água				FOC460/1			
1621 LK - OM 366 A/LA	01/89-			FOC1059			
	-12/95	FA4650/1	FO366			FA840	ES
	01/96-	FA9836	FO301				
Separador de água	-11/95			FOC530/1			
Separador de água	01/96-			FOC460/1			
1622 L - OM 924 LA	01/01-	FA9837				FO346	H
						FA837	ES
Separador de água	-11/04			FOC480			
Separador de água	12/04-			FOC480/1			
1622 L/LS - OM 366 A/LA	01/89-	FA4650/1		FOC1059		FA840	ES
	-12/95		FO366				
	01/96-		FO301				
Separador de água	-11/95			FOC530/1			
Separador de água	01/96-			FOC460/1			
1625 L/LS - OM 449 A/LA	01/90-	FA4650/1	FO449			FA840	ES
Separador de água				FOC530/1			
1630 LS - OM 449 A/LA	01/90-	FA4650/1	FO449			FA840	ES
Separador de água				FOC530/1			
1632 LS - OM 449 A/LA	01/99-	FA9835	FO449			FA860	ES
Separador de água				FOC460/1			
1633 L - OM 449 A/LA	01/90-	FA4650/1	FO449			FA860	ES
Separador de água				FOC530/1			
1634 LS - OM 447 LA	01/00-	FA9840				FA1163	ES
Separador de água				FOC460/1			
1634 LS - OM 457 LA	01/06-	FA9840				FO346	H
Separador de água				FOC1085			
17t-Serie							
1714 L - OM 366 LA	01/96-	FA9836	FO301				
Separador de água				FOC460/1			

CB - Câmbio
DH - Direção hidráulica
ES - Elemento de segurança

FAS - Filtro do ar seco
FC - Filtro do ar para cabine
H - Hidráulico

PC - Precarga
TR - Transmissão hidráulica
Refr. - Filtro de refrigeração



MODELO/ MOTOR

tipo filtro

MERCEDES-BENZ (cont.)

CAMINHÕES

17t-Serie

MODELO/ MOTOR		ar	óleo	combustível	cabine	diversos	
1714 L/LK - OM 366 Separador de água	01/89-12/95	FA9834	FO519	FOC1058 FOC530/1		FA820	ES
1718 K-A - OM 366 A/LA Separador de água	01/91- -12/95	FA9834	FO366	FOC1059		FA820	ES
Separador de água	01/96- -12/95	FA9836	FO301	FOC530/1 FOC460/1			
1718 M - OM 904 LA Separador de água	01/98- -11/04	FA9838		FOC480			
Separador de água	12/04-			FOC480/1			
1720 K-A - OM 366 A/LA Separador de água	01/96-	FA9836	FO301	FOC460/1			
1721 LK/LS-S - OM 366 A/LA Aplicação em condições severas - Modelo Canavieiro	01/90- -12/95	FA9834	FO366	FOC1059		FA840 FA820	ES ES
Separador de água	01/96- -12/95	FA9836 FA4650/1	FO301	FOC530/1			
Separador de água	01/96-			FOC460/1			
1723 L - OM 906 LA Separador de água	01/98- -11/04	FA9836		FOC480			
Separador de água	12/04-			FOC480/1			
1723 S - OM 366 A/LA Separador de água	01/96-	FA9836	FO301	FOC460/1			
1728 - OM 906 LA Separador de água	01/98- -11/04	FA9836		FOC480			
Separador de água	12/04-			FOC480/1			
19t-Serie							
1924 LS - OM 355/6 Separador de água	01/79- -12/82	FA9834	FO345	FOC1060		FA820	ES
Separador de água	01/83-	FA4650/1				FA840	ES
1929 L - OM 447 A Separador de água	01/90-	FA9835				FA860	ES
1929 LS - OM 355/6 A/LA Separador de água	01/83-	FA4650/1	FO345	FOC1060		FA840	ES
1932 LS - OM 355/6 A/LA Separador de água	01/83-	FA4650/1	FO345	FOC1060 FOC530/1		FA840	ES
1933 LS - OM 355/6 A/LA Separador de água	01/87-	FA4650/1	FO345	FOC1060 FOC530/1		FA840	ES
1934 LS - OM 355/6 A/LA Separador de água	01/87-	FA4650/1	FO345	FOC1060 FOC530/1		FA840	ES
1935 LS - OM 447 A/LA Separador de água	01/90-	FA9835		FOC530/1		FA860	ES
1938 LS - OM 457 LA Separador de água	01/98- -11/04	FA9835		FOC1085		FA860	ES
1938 LS-S - OM 447 LA Separador de água	01/96-	FA9835		FOC1060 FOC460/1		FA860	ES
1938 S - OM 457 LA Separador de água	01/99- -11/04	FA9840		FOC1085		FA1163	ES
1941 LS - OM 447 LA Separador de água	01/90-	FA9835		FOC1060 FOC530/1		FA860	ES
1944 S - OM 457 LA Separador de água	01/02- -11/04	FA9840		FOC1085		FA1163	ES
Separador de água	12/04-			FOC480/1			
20t-Serie							
2013 L - OM 352 Separador de água	01/79-	FA9834	FO519	FOC1058		FA820	ES
2014 - OM 352 A	01/75-	FA9834	FO519	FOC1058		FA820	ES



Linha de produtos Magneti Marelli
Filtro ar, óleo, cabine e combustível



MODELO/ MOTOR		ar	óleo	combustível	cabine	diversos	tipo filtro

MERCEDES-BENZ (cont.)

CAMINHÕES

22t-Serie

2213 L/LK/LB - OM 352	01/75-	FA9834	FO519	FOC1058		FA820	ES
2214 L/LK - OM 352	01/75-	FA9834	FO519	FOC1058		FA820	ES
2215 LK - OM 366	01/84-	FA9834	FO519	FOC1058		FA820	ES
Separador de água				FOC530/1			
2216 L/LK/LB - OM 366	01/80-	FA9834	FO519	FOC1058		FA820	ES
2217 L/LK/LB - OM 366	01/87-	FA9834	FO519	FOC1058		FA820	ES
Separador de água				FOC530/1			
2219 L/LK/LB - OM 355/5	01/80-	FA9834	FO345	FOC1060		FA820 FA830	ES ES
Aplicação em condições severas - Modelo Canavieiro		FA4440					
2220 L/LK/LB - OM 355/5	01/79-	FA9834	FO345	FOC1060		FA820 FA830	ES ES
Aplicação em condições severas - Modelo Canavieiro		FA4440					
2225 L - OM 449 A	01/90-	FA4650/1	FO449			FA840	ES
Separador de água				FOC530/1			
2225 L/LS - OM 355/5 A	01/89-	FA4440	FO345	FOC1060		FA830	ES
Separador de água				FOC530/1			
2236 L - OM 447 A	01/90-	FA4440		FOC1060		FA830	ES
Separador de água				FOC530/1			
23t-Serie							
2318 L/LK/LB - OM 366 A/LA	01/90-			FOC1059		FO346	H
	-12/95	FA9834	FO366			FA820	ES
Separador de água				FOC530/1			
	01/96-	FA9836	FO301				
Separador de água				FOC460/1			
2318 L/LK/LB - OM 366	01/90-	FA9834	FO519	FOC1059		FO346 FA820	H ES
Separador de água				FOC530/1			
2325 L/LA/LAK - OM 449 A	01/90-	FA4650/1	FO449			FA840	ES
Separador de água	01/92-			FOC530/1			
24t-Serie							
2418 L - OM 366 A/LA	01/92-			FOC1059		FO346	H
	-12/95	FA9834	FO366			FA820	ES
Separador de água				FOC530/1			
	01/96-	FA9836	FO301				
Separador de água				FOC460/1			
2423 B-K - OM 906 LA	01/00-	FA9836				FA839	ES
Separador de água	-11/04			FOC480			
Separador de água	12/04-			FOC480/1			
2428 - OM 906 LA	01/01-	FA9836					
Separador de água	-11/04			FOC480/1			
Separador de água	12/04-			FOC480			
26t-Serie							
2635 L/LS - OM 447 LA	01/94-	FA9835				FA860	ES
Separador de água				FOC530/1			
2638 L/LS/LK - OM 457 LA	01/99-						
	-12/01	FA9835				FA860	ES
	01/02-	FA9840				FA1163	ES
Separador de água	-11/04			FOC1085			
2638 L/LS/LK - OM 447 LA	-12/97	FA9835				FA860	ES
Separador de água				FOC530/1			

CB - Câmbio
DH - Direção hidráulica
ES - Elemento de segurança

FAS - Filtro do ar seco
FC - Filtro do ar para cabine
H - Hidráulico

PC - Precarga
TR - Transmissão hidráulica
Refr. - Filtro de refrigeração



MODELO/ MOTOR		ar	óleo	combustível	cabine	diversos	tipo filtro
							

MERCEDES-BENZ (cont.)

ÔNIBUS

O 364

O 364 - OM 352 01/79- FA9834 FO519 FOC1058 FA820 ES

O 364 - OM 355/5 01/81- FA9834 FO345 FA820 ES

O 365

O 365 - OM 352 01/79- FA9834 FO345 FA820 ES

O 365 - OM 355/5 01/81- FA9834 FO519 FA820 ES

O 370

O 370 - OM 355/5 A/LA 01/85- FA4650/1 FO345 FA840 ES

O 371

O 371 R - OM 355/5 A/LA 01/85- FA4650/1 FO345 FA840 ES

O 371 R - OM 355/6 A 01/85- FA4650/1 FO345 FA840 ES

O 371 U/ST - OM 366 A/LA 01/85- FA9834 FO366 FOC1058 FA820 ES

O 400

O 400 RSD/RSE - OM 447 LA 01/95- FA9835 FO346 H

FA860 ES

Separador de água FOC530/1

O 400 RSD/RSE - OM 457 LA 01/98- FA9835 FO346 H

FA860 ES

Separador de água FOC1085

O 400 UP - OM 449 A/LA 01/95- FA4650/1 FO449 FO346 H

FA840 ES

Separador de água FOC530/1

O 400 UPA - OM 449 A/LA 01/95- FA4650/1 FO449 FO346 H

Alguns modelos FA840 ES

A partir do chassi n°: 088900 FA9835 FA860 ES

Separador de água FOC530/1

O 500

O 500 M - OM 904 LA 01/98- FA9836 FO346 H

Alguns modelos FA9839

Separador de água -11/04 FOC480

O 500 M - OM 906 LA 01/98- FA9836 FO346 H

Alguns modelos FA9839

Separador de água -11/04 FOC480

O 500 M - OM 926 LA 01/00- FA9836 FO346 H

Alguns modelos FA9839

Separador de água -11/04 FOC480

O 500 R - OM 926 LA 01/00- FA9836 FO346 H

Alguns modelos FA9839

Separador de água -11/04 FOC480

Separador de água 12/04- FOC480/1

O 500 RS/RSD - OM 457 LA 01/05- FA9840 FA1163 ES

Separador de água FOC480/1

O 500 U - OM 906 LA 01/98- FA9836 FO346 H

Alguns modelos FA9839

Separador de água -11/04 FOC480

Separador de água 12/04- FOC480/1

Serie 6t

LO 608 - OM 314 01/93- FA8528 FO442 FOC1059 FO346 H

Separador de água FOC530/1

LO 610 - OM 364 A/LA 01/98- FA2710 FO364 FOC1058 FO346 H

FA810 ES

Serie 7t

LO 712 - OM 364 A/LA 01/98- FA2710 FO364 FO346 H

FA810 ES

Separador de água -09/06 FOC1058

10/06- FOC480/1



Linha de produtos Magneti Marelli
Filtro ar, óleo, cabine e combustível



MODELO/ MOTOR		ar	óleo	combustível	cabine	diversos	tipo filtro

MERCEDES-BENZ (cont.)

ÔNIBUS							
Serie 8t							
LO 809 - OM 364	01/85-12/97	FA7998	FO364	FOC1058		FO346 FA820	H ES
Separador de água				FOC530/1			
LO 809 - OM 364 A/LA	01/98-	FA7998	FO364	FOC1058		FO346 FA820	H ES
Separador de água				FOC530/1			
LO 812 - OM 364 A/LA	10/90- -09/06 -12/99		FO364	FOC1058		FO346 FA820	H ES
A partir do chassi nº: 339846	01/00-	FA2710				FA810	ES
Alguns modelos	01/04-	FA9838					
Separador de água	-09/06			FOC530/1			
Separador de água	10/06-			FOC480/1			
LO 813 - OM 364 A/LA	01/90-	FA7998	FO364	FOC1058		FO346 FA820	H ES
Separador de água				FOC530/1			
LO 814 - OM 364 A/LA	01/98-	FA7998	FO364	FOC1058		FO346 FA820	H ES
Separador de água				FOC530/1			
Serie 9t							
LO 914 - OM 904 LA	01/98-	FA9838				FO346	H
Separador de água				FOC480			
LO 915 - OM 904 LA	01/05-	FA9838				FO346	H
Separador de água				FOC480/1			
Serie 11t							
OF/ LO 1115 - OM 366 A	-12/95	FA9834	FO366	FOC1059		FO346 FA820	H ES
Separador de água				FOC530/1			
Serie 13t							
OF 1314 - OM 352	01/87-	FA9834	FO519	FOC1058		FO346 FA820	H ES
OF 1315 - OM 366 A	01/87-	FA9834	FO366	FOC1058		FO346 FA820	H ES
OF 1318 - OM 366 LA	01/97-	FA9834	FO301	FOC1058		FO346 FA820	H ES
OH 1313 - OM 352	-12/87	FA9834	FO519	FOC1058		FO346 FA820	H ES
OH 1315 - OM 366 A	01/87-	FA9834	FO366	FOC1058		FO346 FA820	H ES
OH 1318 - OM 366 A	01/90-	FA9834	FO301	FOC1058		FO346 FA820	H ES
Serie 14t							
OF 1417 - OM 904 LA	01/97-	FA9838				FO346	H
Separador de água	-11/04			FOC480			
Separador de água	12/04-			FOC480/1			
OF 1418 - OM 904 LA	01/04-	FA9838				FO346	H
Separador de água	-11/04			FOC480			
Separador de água	12/04-			FOC480/1			
OH 1417 - OM 904 LA	01/03-	FA9836				FO346	H
Separador de água	-11/04			FOC480			
Separador de água	12/04-			FOC480/1			
OH 1418 - OM 366 LA	01/95-	FA4650/1	FO301	FOC460/1		FA840	ES



MODELO/ MOTOR		ar	óleo	combustível	cabine	diversos	tipo filtro
							

MERCEDES-BENZ (cont.)

ÔNIBUS

Serie 14t

OH 1418 EL - OM 904 LA

Separador de água

Separador de água

OH 1419 - OM 366 A

OH 1420 - OM 366 LA

OH 1421 - OM 366 LA

A partir do chassis n°: 199121

Serie 15t

OH 1517 - OM 355/5

OH 1518 - OM 355/5

OH 1518 - OM 904 LA

Separador de água

Separador de água

OH 1520 - OM 355/5

Serie 16t

OF 1620 - OM 366 A/LA

Separador de água

OH 1621 L/LE - OM 366 LA

A partir do chassis n°: 199121

OH 1623 LG - OM 366 LGA

A partir do chassis n°: 199121

OH 1628 L - OM 449 LA

Separador de água

Separador de água - chassis a partir: 177267

OH 1630 - OM 449 LA

Serie 17t

OF 1721 - OM 366 LA

OF 1721 - OM 906 LA

Separador de água

Separador de água

OF 1722 - OM 906 LA

Alguns modelos

Separador de água

Separador de água

OF 1722 M - OM 924 LA

Separador de água

Separador de água

	01/03- -11/04 12/04-	FA9836		FOC480 FOC480/1		FO346	H
	01/80-	FA9834	FO301	FOC1058		FO346 FA820	H ES
	01/98-	FA9837	FO301	FOC460/1		FO346 FA837	H ES
	01/03-	FA4650/1	FO301	FOC460/1		FO346 FA840	H ES
		FA9837				FA837	ES
	01/79-	FA9834	FO345			FA820	ES
	01/79-	FA9834	FO345			FA820	ES
	01/00- -11/04 12/04-	FA9836		FOC480 FOC480/1		FO346	H
	01/79-	FA9834	FO345			FA820	ES
	01/93-	FA9834	FO301	FOC1058		FO346 FA820	H ES
				FOC530/1			
	01/03-	FA4650/1	FO301	FOC460/1		FO346 FA840	H ES
		FA9837				FA837	ES
	01/98-	FA4650/1	FO301			FO346 FA840	H ES
		FA9837				FA837	ES
	01/98-	FA9835	FO449			FO346 FA860	H ES
				FOC530/1 FOC460/1			
	01/93-	FA9835	FO449			FO346 FA860	H ES
	01/97-	FA9837	FO301	FOC460/1		FO346 FA837	H ES
	01/98-	FA9837				FO346 FA837	H ES
	-11/04 12/04-			FOC480 FOC480/1			
	01/98-	FA9837				FO346 FA837	H ES
		FA9839				FA839	ES
	-11/04 12/04-			FOC480 FOC480/1			
	01/98-	FA9837				FO346 FA837	H ES
	-11/04 12/04-			FOC480 FOC480/1			



Linha de produtos Magneti Marelli
Filtro ar, óleo, cabine e combustível



MODELO/ MOTOR		ar	óleo	combustível	cabine	diversos	tipo filtro

PUMA

CAMINHÕES

10T-Serie

10T - Perkins

4 T-Serie

4 T 4000 - MWM D229/4

4 T 4000 - Perkins 4.236

4 T 6000 - MWM D229/4

4 T 6000 - Perkins 4.236

9000

9000 - MWM TD 229 E24 Turbo

914

914 - MWM D 229/4

RANDON

CAMINHÕES

RK-Serie

RK 430 / RK 425B - DS11 6Cil.

SANTA MATILDE

PADRON 16180

PADRON 16180 - GM 292 Gás Metano

SCANIA

CAMINHÕES

L

L 110 - D11

L 111 - DS11

Separador de água

L 75/ L 76 - D11

G (G230 - G480)

G 380 - D12-17

Para referência original: 1423414 e/ou 1872152

Para referência original: 1485592

Separador de água

G 380 - DC12-17 - Euro 3

Para referência original: 1423414 e/ou 1872152

Para referência original: 1485592

Separador de água

G 420 - D12-06 - Euro 3

Para referência original: 1423414 e/ou 1872152

Para referência original: 1485592

Separador de água

G 420 - DC12-06 - Euro 3

Para referência original: 1423414 e/ou 1872152

Para referência original: 1485592

Separador de água

G 440 - DT12-18 - Euro 3

Para referência original: 1423414 e/ou 1872152

Para referência original: 1485592

Separador de água

G 470 - DT12-06

Para referência original: 1423414 e/ou 1872152

Para referência original: 1485592

Separador de água

CB - Câmbio
DH - Direção hidráulica
ES - Elemento de segurança

FAS - Filtro do ar seco
FC - Filtro do ar para cabine
H - Hidráulico

PC - Precarga
TR - Transmissão hidráulica
Refr. - Filtro de refrigeração



MODELO/ MOTOR		ar	óleo	combustível	cabine	diversos	tipo filtro
							

SCANIA (cont.)

CAMINHÕES

P (P230 - P470)

P 230 - DC9-13 Separador de água	11/06-	FA9840	FO174		FOC490/1	FO346	H
P 230 - DC9-19 Separador de água	01/04-		FO174		FOC490/1	FO346	H
P 270 - DC9-12 Separador de água	11/06-	FA9840	FO174		FOC490/1	FO346	H
P 270 - DC9-20 Separador de água	01/04-		FO174		FOC490/1	FO346	H
P 310 - DC9-11 Separador de água	11/06-	FA9840	FO174		FOC490/1	FO346	H
P 310 - DC 9-21 Separador de água	01/04-	FA9840	FO174		FOC490/1	FO346 FA1163	H ES
P 340 - DC 11-03 Separador de água	01/04-	FA1189	FO174		FOC490/1	FO346	H
P 340 - DC11-08 Separador de água	11/06-	FA9840	FO174		FOC490/1	FO346	H
P 420 - DC 12-01 Separador de água	01/04-	FA1189	FO174	FOC84	FOC490/1	FO346	H
P 420 - DC12-06 - Euro 3 Separador de água	11/06-	FA9840	FO174		FOC490/1	FO346	H
R / New R (R230 - R620)							
R 420 HighLine - 4x2 / 6x2 / 6x4 - DC12-06 Separador de água	01/08-				FOC490/1	FO346	H
R 440 HighLine - 4x2 / 6x2 / 6x4 - DT12-18 Separador de água	01/08-				FOC490/1	FO346	H
R 470 HighLine - 4x2 / 6x2 / 6x4 - DT12-06 Separador de água	01/08-				FOC490/1	FO346	H
R 500 HighLine - 4x2 / 6x2 / 6x4 - DC16-04 Separador de água	01/08-				FOC490/1	FO346	H
R 380 - DC 11-04 Para referência original: 1423414 e/ou 1872152 Para referência original: 1485592 Separador de água	01/05-	FA1189 FA9840	FO174	FOC84	FOC490/1	FO346	H
R 420 - DC12-06 Para referência original: 1423414 e/ou 1872152 Para referência original: 1485592 Separador de água	11/06-	FA1189 FA9840	FO174		FOC490/1	FO346	H
R 420 - DC 12-01 Para referência original: 1423414 e/ou 1872152 Para referência original: 1485592 Separador de água	01/05-	FA1189 FA9840	FO174	FOC84	FOC490/1	FO346	H
R 440 - DT12-18 Para referência original: 1423414 e/ou 1872152 Para referência original: 1485592 Separador de água	11/06-	FA1189 FA9840	FO174		FOC490/1	FO346	H
R 470 - DT12-06 Para referência original: 1423414 e/ou 1872152 Para referência original: 1485592 Separador de água	11/06-	FA1189 FA9840	FO174		FOC490/1	FO346	H
R 480 - DC 16-02 Para referência original: 1423414 e/ou 1872152 Para referência original: 1485592 Separador de água	01/05-	FA1189 FA9840	FO174		FOC490/1	FO346	H



Linha de produtos Magneti Marelli
Filtro ar, óleo, cabine e combustível



MODELO/ MOTOR		ar	óleo	combustível	cabine	diversos	tipo filtro

SCANIA (cont.)

MODELO/ MOTOR		ar	óleo	combustível	cabine	diversos	tipo filtro
CAMINHÕES							
R / New R (R230 - R620)							
R 500 - DC16-04	11/06-	FA1189					
Para referência original: 1423414 e/ou 1872152		FA9840					
Para referência original: 1485592							
Serie 1 (141)							
R / T 141LK / LKS / LKT - DS14	01/77-	FA9835	FO171	FOC72/2		FO346 FA860	H ES
2 (82-142)							
112 R/T/K/S - HS/HW/EW - DSC11	01/81-	FA1185	FO171	FOC72/2		FO346 FA860	H ES
Com conexão para aspiração de água		FA1186					
Separador de água				FOC204			
112 R/T/K/S - HS/HW/EW - DSC14	01/81-	FA1185	FO171	FOC72/2		FO346 FA860	H ES
Com conexão para aspiração de água		FA1186					
Separador de água				FOC204			
142 R/T - E/H/EW/HW/HS - DS14,DSC14	01/81-	FA1185	FO171	FOC72/2		FO346 FA860	H ES
Com conexão para aspiração de água		FA1186					
Separador de água				FOC204			
142 R/T - E/H/EW/HW/HS - DS11	01/81-	FA1185	FO171	FOC72/2		FO346 FA860	H ES
Com conexão para aspiração de água		FA1186					
Separador de água				FOC204			
142 R/T - HW/EW - DSC11	01/81-	FA1185	FO171	FOC72/2		FO346 FA860	H ES
Com conexão para aspiração de água		FA1186					
Separador de água				FOC204			
142 R/T - HW/EW - DSC14	01/81-	FA1185	FO171	FOC72/2		FO346 FA860	H ES
Com conexão para aspiração de água		FA1186					
Separador de água				FOC204			
3 (93-143)							
P 93 - H/HS - DS9	01/95-	FA1186	FO171	FOC72/2		FO346 FA860	H ES
Separador de água				FOC204			
113 R/T - HK - DS11,DSC11,DSC14	01/81-	FA1186	FO171	FOC72/2		FO346 FA860	H ES
Separador de água				FOC204			
113 R/T - H - DSC11,DSC14	01/91-	FA1186	FO171	FOC72/2		FO346 FA860	H ES
Separador de água				FOC204			
4 (94-164)							
114 P/R/T - DC11,DSC11-07	01/97- 01/98-	FA1189		FOC84	FH500202	FO346	H
Para referência original: 173 171			FO171				
Para referência original: 111 7285			FO174				
Separador de água				FOC490/1			
124 P/R/T - 360cv/400cv - DSC 12-01,02,09	01/98-	FA1189	FO174	FOC84	FH500202	FO346	H
Separador de água				FOC490/1			
124 P/R/T - DSC12-02	03/99-	FA1189	FO174		FH500202	FO346	H
Separador de água				FOC490/1			
164 R - DC16-02	01/02-	FA1189				FO346	H
Separador de água				FOC490/1			

filtro

173

CB - Câmbio
DH - Direção hidráulica
ES - Elemento de segurança

FAS - Filtro do ar seco
FC - Filtro do ar para cabine
H - Hidráulico

PC - Precarga
TR - Transmissão hidráulica
Refr. - Filtro de refrigeração



MODELO/ MOTOR		ar	óleo	combustível	cabine	diversos	tipo filtro
							

SCANIA (cont.)

CAMINHÕES

4 (94-164)

94 P/R/T - CB/DB (220cv/260cv) - DSC9-12

Separador de água

01/97-

FA1189

FO174

FOC84
FOC490/1

FO346

H

140-Serie

R / T 140 LK / LKS - DS14

Separador de água

01/77-

FA9835

FO171

FOC72/2
FOC204

FO346
FA860

H
ES

ÔNIBUS

B-Serie

B 115 - DS11 / DN11

Separador de água

01/75-

FA4650/1

FO171

FOC72/2
FOC204

FO346
FA840

H
ES

BR 111 - DS11 / DN11

Separador de água

01/75-

FA4650/1

FO171

FOC72/2
FOC204

FO346
FA840

H
ES

BR 116 - DS11 / DN11

Separador de água

01/75-

FA4650/1

FO171

FOC72/2
FOC204

FO346
FA840

H
ES

F-Serie

F 112 - DS11 / DN11

Separador de água

01/75-

FA4650/1

FO171

FOC72/2
FOC204

FO346
FA840

H
ES

F 113 - DN11/DS11/DSC11

Separador de água

10/92-

FA4650/1

FO171

FOC72/2
FOC204

FO346
FA840

H
ES

F 94 - DSC9-11,DC9-01,9-03

Separador de água

01/98-

FA4650/1

FO171
FO174

FOC72/2
FOC84
FOC490/1

FO346
FA840

H
ES

K-Serie

K 94 - DSC 9-15

Separador de água

01/98-

FO174

FOC84
FOC490/1

FO346

H

K 112 - DSC11

Separador de água

01/86-

FO171

FOC72/2
FOC204

FO346
FA840

H
ES

K 113 - DSC11-21 / DSC11-23

Separador de água

01/97-

FA4650/1

FO171

FOC72/2
FOC204

FO346
FA840

H
ES

K 114 - DSC11,DSC12-02,DSC12-01,DC12-01

Separador de água

01/98-
01/03-

FA9840

FO174

FOC84
FOC490/1

FO346
FA1163

H
ES

K 114 - DSC12-02 / DC12-05

Separador de água

01/03-

FA9840

FO174

FOC490/1

FO346
FA1163

H
ES

K 124 - DSC12-02,DSC12-01,DC12-02

Separador de água

01/98-

FO174

FOC84
FOC490/1

FO346

H

K 124 - DSC12-05/DC12-05

Separador de água

01/03-

FA9840

FO174

FOC490/1

FO346
FA1163

H
ES

K 230 - DC 9-19 L5

Separador de água

01/05-

FO174

FOC490/1

FO346

H

K 270 - DC 9-20

Separador de água

01/05-

FA9840

FO174

FOC490/1

FO346
FA1163

H
ES



Linha de produtos Magneti Marelli
Filtro ar, óleo, cabine e combustível



MODELO/ MOTOR		ar	óleo	combustível	cabine	diversos	tipo filtro

SCANIA (cont.)

ÔNIBUS							
K-Serie							
K 310 - DC 9-21	01/05-	FA9840	FO174			FO346 FA1163	H ES
Separador de água				FOC490/1			
K 340 - DC 11-03	01/05-	FA9840	FO174			FO346 FA1163	H ES
Separador de água				FOC490/1			
K 360 - DSC 12-02	01/05-	FA9840	FO174	FOC84		FO346 FA1163	H ES
Separador de água				FOC490/1			
K 380 - DC 11-04	01/05-	FA9840	FO174	FOC84		FO346 FA1163	H ES
Separador de água				FOC490/1			
K 420 - DSC 12-01	01/05-	FA9840	FO174	FOC84		FO346 FA1163	H ES
Separador de água				FOC490/1			
L-Serie							
L 113 - DS11,DSC11-75,DSC11-78	01/97-	FA4650/1	FO171	FOC72/2		FO346 FA840	H ES
Separador de água				FOC204			
L 94 - DSC9-01 / DC9-02	03/97- 01/05-		FO174	FOC84		FO346 FA1163	H ES
Separador de água		FA9840		FOC490/1			
S-Serie							
S 112 - DSC11 / DS14		FA4650/1	FO171	FOC72/2		FO346 FA840	H ES
Separador de água				FOC204			

VOLVO

CAMINHÕES							
Serie FH 12 (BR)							
FH 12 340 - D12C	01/01-		FO417	FOC79		FO346	H
Fluxo secundário			FO419				
Separador de água				FOC490/1			
FH 12 340 - D12D	01/03-		FO417			FO346	H
Fluxo secundário			FO419				
FH 12 380 - D12A	01/94-		FO417	FOC79		FO346	H
Fluxo secundário			FO419				
Separador de água				FOC470/1			
FH 12 380 - D12C	01/98-		FO417	FOC79		FO346	H
Fluxo secundário			FO419				
Separador de água				FOC490/1			
FH 12 380 - D12D	01/03-		FO417			FO346	H
Fluxo secundário			FO419				
FH 12 400 - D13A	11/06-		FO417		FH510402	FO346	H
Fluxo secundário			FO419				
FH 12 420 - D12A	01/96-		FO417	FOC79		FO346	H
Fluxo secundário			FO419				
Separador de água				FOC470/1			
FH 12 420 - D12C	01/98-		FO417	FOC79		FO346	H
Fluxo secundário			FO419				
Separador de água				FOC490/1			
FH 12 420 - D12D	01/03-		FO417			FO346	H
Fluxo secundário			FO419				

CB - Câmbio
DH - Direção hidráulica
ES - Elemento de segurança

FAS - Filtro do ar seco
FC - Filtro do ar para cabine
H - Hidráulico

PC - Precarga
TR - Transmissão hidráulica
Refr. - Filtro de refrigeração

filtro

175



MODELO/ MOTOR		ar 	óleo 	combustível 	cabine 	diversos 	tipo filtro
---------------	---	---	---	--	---	---	-------------

VOLVO (cont.)

CAMINHÕES

Serie FH 12 (BR)

FH 12 440 - D13A

Fluxo secundário

FH 12 460 - D12D

Fluxo secundário

FH 12 480 - D13A

Fluxo secundário

FH 12 520 - D13A

Fluxo secundário

Serie FM 12 (BR)

FM 12 340 - D12C

Fluxo secundário

Separador de água

FM 12 340 - D12D

Fluxo secundário

FM 12 380 - D12C

Fluxo secundário

Separador de água

FM 12 380 - D12D

Fluxo secundário

FM 12 400 - D13A

Fluxo secundário

FM 12 420 - D12C

Fluxo secundário

Separador de água

FM 12 420 - D12D

Fluxo secundário

FM 12 440 - D13A

Fluxo secundário

FM 12 460 - D12D

Fluxo secundário

FM 12 480 - D13A

Fluxo secundário

FM 12 520 - D13A

Fluxo secundário

Serie N 10 (BR)

N10 H/XH/XHT - TD101F/TD101G

Separador de água

N1016 - TD100G

Separador de água

N1020 - TD100A/TD100G

Separador de água

N1033 - TD100G

Separador de água

Serie N 12 (BR)

N12 H/XH/XHT - TD121G

Separador de água

N1220 - TD120GA

Separador de água

N1223 - TD120GA

Separador de água

Serie NH 12 (BR)

NH 12 340 - D12C

Fluxo secundário

Separador de água

NH 12 340 - D12C

Fluxo secundário

Separador de água

NH 12 340 - D12C

Fluxo secundário

Separador de água

MODELO/ MOTOR		ar 	óleo 	combustível 	cabine 	diversos 	tipo filtro
Serie FH 12 (BR) FH 12 440 - D13A Fluxo secundário	11/06-		FO417 FO419			FO346	H
FH 12 460 - D12D Fluxo secundário	01/04-		FO417 FO419			FO346	H
FH 12 480 - D13A Fluxo secundário	11/06-		FO417 FO419			FO346	H
FH 12 520 - D13A Fluxo secundário	11/06-		FO417 FO419			FO346	H
Serie FM 12 (BR) FM 12 340 - D12C Fluxo secundário Separador de água	01/00-		FO417 FO419	FOC79 FOC490/1		FO346	H
FM 12 340 - D12D Fluxo secundário	01/03-		FO417 FO419			FO346	H
FM 12 380 - D12C Fluxo secundário Separador de água	01/01-		FO417 FO419	FOC79 FOC490/1		FO346	H
FM 12 380 - D12D Fluxo secundário	01/03-		FO417 FO419			FO346	H
FM 12 400 - D13A Fluxo secundário	11/06-		FO417 FO419			FO346	H
FM 12 420 - D12C Fluxo secundário Separador de água	01/00-		FO417 FO419	FOC79 FOC490/1		FO346	H
FM 12 420 - D12D Fluxo secundário	01/03-		FO417 FO419			FO346	H
FM 12 440 - D13A Fluxo secundário	11/06-		FO417 FO419			FO346	H
FM 12 460 - D12D Fluxo secundário	01/04-		FO417 FO419			FO346	H
FM 12 480 - D13A Fluxo secundário	11/06-		FO417 FO419			FO346	H
FM 12 520 - D13A Fluxo secundário	11/06-		FO417 FO419			FO346	H
Serie N 10 (BR) N10 H/XH/XHT - TD101F/TD101G Separador de água	01/84-		FO417	FOC72/2 FOC204		FO346	H
N1016 - TD100G Separador de água	01/83-		FO417	FOC72/2 FOC204		FO346	H
N1020 - TD100A/TD100G Separador de água	01/80-		FO417	FOC72/2 FOC204		FO346	H
N1033 - TD100G Separador de água	01/83-		FO417	FOC72/2 FOC204		FO346	H
Serie N 12 (BR) N12 H/XH/XHT - TD121G Separador de água	01/84-		FO417	FOC72/2 FOC204		FO346	H
N1220 - TD120GA Separador de água	01/81-		FO417	FOC72/2 FOC204		FO346	H
N1223 - TD120GA Separador de água	01/83-		FO417	FOC72/2 FOC204		FO346	H
Serie NH 12 (BR) NH 12 340 - D12C Fluxo secundário Separador de água	01/99-		FO417 FO419	FOC79 FOC490/1		FO346	H



Linha de produtos Magneti Marelli
Filtro ar, óleo, cabine e combustível



MODELO/ MOTOR		ar	óleo	combustível	cabine	diversos	tipo filtro

VOLVO (cont.)

CAMINHÕES

Serie NH 12 (BR)

NH 12 340 - D12D	01/03-		FO417			FO346	H
Fluxo secundário			FO419				
NH 12 380 - D12C	01/98-		FO417	FOC79		FO346	H
Fluxo secundário			FO419				
Separador de água				FOC490/1			
NH 12 380 - D12D	01/03-		FO417			FO346	H
Fluxo secundário			FO419				
NH 12 420 - D12C	01/98-		FO417	FOC79		FO346	H
Fluxo secundário			FO419				
Separador de água				FOC490/1			
NH 12 420 - D12D	01/03-		FO417			FO346	H
Fluxo secundário			FO419				
NH 12 460 - D12D	01/04-		FO417			FO346	H
Fluxo secundário			FO419				

Serie NL 10 (BR)

NL 10 280 - TD101G	01/90-		FO417	FOC72/2	FH510402	FO346	H
Separador de água				FOC204			
NL 10 310 - TD102FT	01/93-		FO417	FOC72/2		FO346	H
Separador de água				FOC204			
NL 10 320 - D10A	01/96-		FO417	FOC79	FH510402	FO346	H
Fluxo secundário			FO419				
Separador de água				FOC490/1			
NL 10 340 - TD102FS	01/90-		FO417	FOC79	FH510402	FO346	H
Separador de água				FOC490/1			

Serie NL 12 (BR)

NL 12 360 - TD122F	01/93-		FO417	FOC79	FH510402	FO346	H
Fluxo secundário			FO419				
Separador de água				FOC490/1			
NL 12 360 - TD123E	01/95-		FO417	FOC79	FH510402	FO346	H
Fluxo secundário			FO419				
Separador de água				FOC490/1			
NL 12 400 - TD122FS	01/89-		FO417	FOC72/2	FH510402	FO346	H
Separador de água				FOC204			
NL 12 410 - TD122FR	01/93-		FO417	FOC72/2	FH510402	FO346	H
Separador de água				FOC204			
NL 12 410 - TD123ES	01/95-		FO417	FOC79	FH510402	FO346	H
Fluxo secundário			FO419				
Separador de água				FOC490/1			

Serie VM (BR)

VM 17 210 - MWM6A206	01/04-	FA9840	FO417	FOC79		FO346	H
Separador de água				FOC490/1		FA1163	ES
VM 17 240 - MWM6A240	01/04-	FA9840	FO417	FOC79		FO346	H
Separador de água				FOC490/1		FA1163	ES
VM 15 210 - MWM5A206	01/05-	FA9840	FO417			FO346	H
Separador de água						FA1163	ES
VM 23 240 - MWM6A240	01/04-	FA9840	FO417	FOC79		FO346	H
Separador de água				FOC490/1		FA1163	ES
VM 260 - MWM7A260	01/05-	FA9840	FO417			FO346	H
Separador de água						FA1163	ES

CB - Câmbio
DH - Direção hidráulica
ES - Elemento de segurança

FAS - Filtro do ar seco
FC - Filtro do ar para cabine
H - Hidráulico

PC - Precarga
TR - Transmissão hidráulica
Refr. - Filtro de refrigeração



MODELO/ MOTOR		ar 	óleo 	combustível 	cabine 	diversos 	tipo filtro
---------------	---	---	---	--	---	---	-------------

VOLVO (cont.)

CAMINHÕES

Serie VM (BR)

VM 310 - MWM7A310

01/05-

FA9840

FO417

FO346

H

FA1163

ES

VW 23 210 - MWM6A206

01/04-

FA9840

FO417

FOC79

FO346

H

FA1163

ES

Separador de água

FOC490/1

ÔNIBUS

B 7

B7R 230 PB - D7B

01/99-

FO417

FOC79

FO346

H

08/02-

FA9837

FA837

ES

Fluxo secundário

FO419

Separador de água

FOC490/1

B7R 260 PB - D7A

08/01-

FO417

FOC79

FO346

H

08/02-

FA9837

FA837

ES

Fluxo secundário

FO419

Separador de água

FOC490/1

B7R 260 PB - D7B

08/01-

FO417

FOC79

FO346

H

08/02-

FA9837

FA837

ES

Fluxo secundário

FO419

Separador de água

FOC490/1

B7R 285 - D7A

01/98-

FO417

FOC79

FO346

H

08/02-

FA9837

FA837

ES

Fluxo secundário

FO419

Separador de água

FOC490/1

B 10

B 10 R - THD100D/THD102KF

06/78-09/92

FO417

FOC79

FO346

H

Fluxo secundário

FO419

Separador de água

FOC490/1

B10M - THD101KC

01/87-

FO417

FOC79

FO346

H

Fluxo secundário

FO419

Separador de água

FOC490/1

B10M - Eco Articulado - THD102KF

01/97-

FO417

FOC79

FO346

H

Fluxo secundário

FO419

Separador de água

FOC490/1

B10M 245 EDC - DH10A245

01/98-

FO417

FOC79

FO346

H

Fluxo secundário

FO419

Separador de água

FOC490/1

B10M 245 EDC - Bi-articulado - DH10A245

01/98-

FO417

FOC79

FO346

H

Fluxo secundário

FO419

Separador de água

FOC490/1

B10M 285 EDC - DH10A285

01/98-

FO417

FOC79

FO346

H

Fluxo secundário

FO419

Separador de água

FOC490/1

B10M 285 EDC - Bi-articulado - DH10A285

01/98-

FO417

FOC79

FO346

H

Fluxo secundário

FO419

Separador de água

FOC490/1

B10M 285 EDC - Articulado - DH10A285

01/98-

FO417

FOC79

FO346

H

Fluxo secundário

FO419

Separador de água

FOC490/1

B10M 310 - THD101KC

01/98-

FO417

FOC79

FO346

H

Fluxo secundário

FO419

Separador de água

FOC490/1



Linha de produtos Magneti Marelli
Filtro ar, óleo, cabine e combustível



MODELO/ MOTOR		ar	óleo	combustível	cabine	diversos	tipo filtro

VOLVO (cont.)

ÔNIBUS							
B 10							
B10M 340 EDC - Articulado - DH10A340	01/98-		FO417	FOC79		FO346	H
Fluxo secundário			FO419				
Separador de água				FOC490/1			
B10M 340 EDC - DH10A340	01/98-		FO417	FOC79		FO346	H
Fluxo secundário			FO419				
Separador de água				FOC490/1			
B 12							
B12 / B12B - TD122FL	01/95-		FO417	FOC79		FO346	H
Fluxo secundário			FO419				
Separador de água				FOC490/1			
B12 360 - TD122FH	01/95-		FO417	FOC79		FO346	H
Fluxo secundário			FO419				
Separador de água				FOC490/1			
B12M 340 - Articulado - DH12D340	01/04-		FO417			FO346	H
Fluxo secundário			FO419				
B12M 340 - Bi-articulado - DH12D340	01/04-		FO417			FO346	H
Fluxo secundário			FO419				
B12R 340 - D12D340	01/03-		FO417			FO346	H
Fluxo secundário			FO419				
B12R 380 - D12D380	01/03-		FO417			FO346	H
Fluxo secundário			FO419				
B12R 420 - D12D420	01/03-		FO417			FO346	H
Fluxo secundário			FO419				
B 58 + B 59							
B 59 T - THD 100 A	03/71-09/72		FO417	FOC72/2		FO346	H
Separador de água				FOC204			
B58 - Articulado - THD101GD	01/89-		FO417	FOC72/2		FO346	H
Fluxo secundário			FO419				
Separador de água				FOC204			
B58 - THD101GC	01/89-		FO417	FOC72/2		FO346	H
Fluxo secundário			FO419				
Separador de água				FOC204			
B58 - Bi-articulado - THD101KB	01/89-		FO417	FOC72/2		FO346	H
Fluxo secundário			FO419				
Separador de água				FOC204			
B58 - Eco / Articulado - THD102KF	01/89-		FO417	FOC72/2		FO346	H
Fluxo secundário			FO419				
Separador de água				FOC204			

VOLKSWAGEN

CAMINHÕES							
L 80							
L 80 - MWM 4.10 T	01/96-	FA7998	FO962	FOC450/1		FO346 FA820	H ES
Serie 5t							
5.140 - Delivery - MWM 4.08 TCE	08/05-	FA7998	FO340			FO346 FA820	H ES
Serie 6t							
6.80 - Perkins 4.236	01/82-		FO900			FO346	H
6.90 - MWM D229/4	01/93-		FO123				
Serie 7t							
7.90 - S - MWM D229/4	01/87-03/94	FA7108	FO123	FOC1059		FO346 FA820	H ES

CB - Câmbio
DH - Direção hidráulica
ES - Elemento de segurança

FAS - Filtro do ar seco
FC - Filtro do ar para cabine
H - Hidráulico

PC - Precarga
TR - Transmissão hidráulica
Refr. - Filtro de refrigeração



MODELO/ MOTOR		ar	óleo	combustível	cabine	diversos	tipo filtro
							

VOLKSWAGEN (cont.)

CAMINHÕES

Serie 7t

7.90 - CO - Perkins 4.236	01/87-	FA7108	FO900	FOC1059		FO346 FA820	H ES
7.100 - MWM 4.10 T	01/87-		FO962				
	-02/94	FA9834					
	-12/99			FOC1059		FO346	H
	03/94-	FA7998				FA820	ES
Separador de água	01/00-			FOC450/1			
7.110 - MWM 4.10 TCA	01/02-	FA7998	FO962			FO346 FA820	H ES
Separador de água				FOC970/1			
7.110 - S - MWM D229/4 T	01/87-03/94	FA9834	FO962	FOC1059		FO346 FA820	H ES

Serie 8t

L 80 - MWM 4.10 T	01/96-12/97	FA7998	FO962	FOC450/1		FO346 FA820	H ES
8.100 - MWM 4.10 T	03/94-	FA7998	FO962			FO346 FA820	H ES
	Separador de água	07/97-		FOC450/1			
8.120 - MWM 4.10 TCA	01/00-	FA7998	FO962			FO346 FA820	H ES
Separador de água				FOC970/1			
8.140 - MWM 4.10 T	03/94-	FA7998	FO962			FO346 FA820	H ES
Separador de água				FOC450/1			
8.150 - MWM 4.10 TCA	01/00-	FA7998	FO962			FO346 FA820	H ES
Separador de água				FOC970/1			
8.150 - MWM 4.07 TCA	01/03-	FA7998	FO340			FO346 FA820	H ES
Separador de água				FOC970/1			
8.150 E - Cummins Int. 4 ISBE	01/03-	FA7998				FO346 FA820	H ES
8.150 E - Delivery - MWM 4.08 TCE	08/05-	FA7998	FO340			FO346 FA820	H ES

Serie 9t

9.150 E - Cummins Int. 4 ISBE	01/03-	FA7998				FO346 FA820	H ES
-------------------------------	--------	--------	--	--	--	----------------	---------

Serie 11t

11.130 - MWM D229/6 T	01/81-	FA2710	FO962	FOC1059		FO346 FA810	H ES
11.140 - MWM D229/6 T	01/88-		FO962	FOC1059		FO346	H
	01/92-	FA5460					
	-12/91	FA2710				FA810	ES
11.140 - Cummins 6CTAA	01/90-	FA5461		FOC72/2		FO346	H
Separador de água				FOC410			

Serie 12t

12.140 - MWM D229/6	01/87-	FA2710	FO962			FO346 FA810	H ES
12.140 H - MWM D229/6	01/87-		FO962	FOC1059		FO346	H
	01/92-	FA5460					
	-12/91	FA2710				FA810	ES
Separador de água				FOC530/1			



Linha de produtos Magneti Marelli
Filtro ar, óleo, cabine e combustível



MODELO/ MOTOR		ar	óleo	combustível	cabine	diversos	tipo filtro

VOLKSWAGEN (cont.)

CAMINHÕES

Serie 12t

12.140 T - MWM 4.10 T

01/92- -03/97 04/97-	FA7998	FO962				FO346	H
				FOC1059			
				FOC450/1		FA820	ES

12.170 BT - Cummins 6BTAA

Separador de água

01/97- -07/99	FA5460	FO280	FOC72/2			FO346	H
			FOC410				

12.180 - MWM 6.10 TCA

Separador de água

01/99-	FA5460	FO339				FO346	H
			FOC450/1				

Serie 13t

13.130 - MWM D229/6

01/81-	FA2710	FO962	FOC1059			FO346 FA810	H ES
--------	--------	-------	---------	--	--	----------------	---------

13.150 - MWM 4.10 TCA

Separador de água

01/00-	FA7998	FO962				FO346 FA820	H ES
			FOC970/1				

13.170 - Cummins 6BTAA

Separador de água - para ref. original: 2R0127177

01/00-	FA9839	FO280	FOC72/2			FO346 FA839	H ES
			FOC970/1				

13.170 E - Cummins Int. 4 ISBE

12/03-	FA9839					FO346 FA839	H ES
--------	--------	--	--	--	--	----------------	---------

13.180 - MWM 6.10 TCA

Separador de água - para ref original: 2R0127177

01/00-	FA9839	FO339	FOC460/1			FO346 FA839	H ES
			FOC970/1				

13.180 - E Worker - MWM 4.12 TCE

12/03-	FA9839					FO346 FA839	H ES
--------	--------	--	--	--	--	----------------	---------

13.180 - Constellation - MWM 4.12 TCE

10/06-		FO962				FO346	H
--------	--	-------	--	--	--	-------	---

13.190 - Cummins 6BTAA

Separador de água - para ref. 2R0127177

01/00-	FA9839	FO280	FOC72/2			FO346 FA839	H ES
			FOC970/1				

13.210 - Cummins 6CT

Separador de água

01/88-12/92	FA4650/1		FOC72/2			FO346 FA840	H ES
			FOC410				

Serie 14t

14.140 - MWM D229/6

01/87-	FA2710	FO962	FOC1059			FO346 FA810	H ES
--------	--------	-------	---------	--	--	----------------	---------

14.150 - MWM 6.10 T

Separador de água

01/91- 04/97-	FA5460	FO339	FOC72/2			FO346	H
			FOC450/1				

14.170 BT - Cummins 6BTAA

Separador de água

01/97- -07/99	FA5460	FO280	FOC72/2			FO346 FRA33	H Refr.
			FOC410				

14.180 - MWM 6.10 T

Separador de água

10/99-	FA5460	FO339				FO346	H
			FOC450/1				

14.200 - Cummins 6CTAA

Separador de água

01/91-	FA5461		FOC72/2			FO346	H
			FOC410				

14.200 - MWM 6.10 T

01/92-	FA5460	FO339	FOC72/2			FO346	H
--------	--------	-------	---------	--	--	-------	---

14.210 - Cummins 6CT

Separador de água

01/88-12/92	FA4650/1		FOC72/2			FO346 FA840	H ES
			FOC410				

14.220 - Cummins 6CTAA

Separador de água

01/91-	FA5461		FOC72/2			FO346	H
			FOC410				

15.160 T - Cummins 6CTAA

12/81-	FA2710	FO962	FOC1059			FO346 FA810	H ES
--------	--------	-------	---------	--	--	----------------	---------

15.170 - Cummins 6BTAA

01/00-	FA9839	FO280	FOC72/2			FO346 FA839	H ES
--------	--------	-------	---------	--	--	----------------	---------

CB - Câmbio
DH - Direção hidráulica
ES - Elemento de segurança

FAS - Filtro do ar seco
FC - Filtro do ar para cabine
H - Hidráulico

PC - Precarga
TR - Transmissão hidráulica
Refr. - Filtro de refrigeração

filtro

IBI



MODELO/ MOTOR		ar	óleo	combustível	cabine	diversos	tipo filtro
							

VOLKSWAGEN (cont.)

CAMINHÕES

Serie 15t

15.170 - Cummins 6BTAA Separador de água - para ref. original: 2R0127177	01/00-			FOC970/1		FRA33	Refr.
15.170 E - Worker - Cummins Int. 4 ISBE	12/03-	FA9839				FO346 FA839	H ES
15.180 - MWM 6.10 TCA Separador de água	01/00-	FA9839	FO339	FOC460/1 FOC970/1		FO346 FA839	H ES
15.180 - Constellation - MWM 4.12 TCE	10/06-		FO962			FO346	H
15.180 - E Worker - MWM 4.12 TCE	05/05-	FA9839	FO962			FO346 FA839	H ES
15.190 - Cummins 6BTAA Separador de água - para ref. original: 2R0127177	01/00-	FA9839	FO280	FOC72/2 FOC970/1		FO346 FA839	H ES
Serie 16t							
16.170 - Cummins 6BTAA Separador de água	01/92-	FA5460	FO280	FOC72/2 FOC410		FO346	H
16.180 - MWM 6.10 T	01/92-	FA5460	FO339	FOC72/2		FO346	H
16.200 - Cummins 6BTAA Separador de água	12/97- -07/99	FA5460	FO280	FOC72/2 FOC410		FO346 FRA33	H Refr.
16.210 - Cummins 6CT Separador de água	01/88-	FA5461		FOC72/2 FOC410		FO346	H
16.220 - Cummins 6CTAA Separador de água	01/91- -07/99	FA5461		FOC72/2 FOC410		FO346	H
16.300 - Cummins 6CTAA Separador de água	06/95-	FA5461		FOC72/2 FOC410		FO346	H
Serie 17t							
17.180 - MWM 6.10 TCA Separador de água	01/06-	FA9839	FO339	FOC460/1 FOC970/1		FO346 FA839	H ES
17.210 - Cummins 6BTAA Separador de água - para ref. original: 2R0127177	01/00-	FA9839	FO280	FOC72/2 FOC970/1		FO346 FA839 FRA33	H ES Refr.
17.210 - MWM 6.10 TCA Separador de água	05/02-	FA9839	FO339	FOC970/1		FO346 FA839	H ES
17.210 - Cummins 6BTAA Separador de água - para ref. original: 2R0127177	05/02-	FA9839	FO280	FOC72/2 FOC970/1		FO346 FA839 FRA33	H ES Refr.
17.220 - Cummins 6CTAA Separador de água	01/91- -07/99	FA5461		FOC72/2 FOC410			
17.220 - Cummins 6BTAA Separador de água - para ref. original: 2R0127177	01/00-	FA9839	FO280	FOC72/2 FOC970/1		FA839 FRA33	ES Refr.
17.220 - Tractor - Cummins 6CTAA Separador de água - para ref. original: 2R0127177	01/00-	FA9839		FOC72/2 FOC970/1		FA839	ES
17.250 E - Worker / Constellation - Cummins Int. 6 ISBE	07/03-	FA9839				FO346 FA839 FRA33	H ES Refr.
17.300 - Cummins 6CTAA Separador de água	01/00- 06/01-	FA9839		FOC72/2 FOC970/1		FO346 FA839	H ES



Linha de produtos Magneti Marelli
Filtro ar, óleo, cabine e combustível



MODELO/ MOTOR		ar	óleo	combustível	cabine	diversos	tipo filtro

VOLKSWAGEN (cont.)

CAMINHÕES							
Serie 17t							
17.300 BT - Cummins 6BTAA	01/92-	FA5461		FOC72/2		FO346	H
Separador de água	-05/01			FOC410			
Separador de água	06/01-			FOC970/1			
17.310 - Titan - Cummins 6CTAA	01/01-	FA9839		FOC72/2		FO346 FA839	H ES
Separador de água	06/01-			FOC970/1			
17.320 - Constellation - Cummins ISC Turbo Intercooler	01/09-	FA9839				FO346 FA839	H ES
Serie 18t							
18.310 - Titan - Cummins 6CTAA	01/01-	FA9839		FOC72/2		FO346 FA839 FRA33	H ES Refr.
Separador de água	06/01-			FOC970/1			
Serie 19t							
19.320 E - Constellation - Cummins ISC 320	11/05-	FA9839				FO346 FA839	H ES
19.370 E - Constellation 4x2 - MWM Int. NGD 370	07/07-	FA9839				FO346	H
Serie 22t							
22.140 - MWM D229/6	01/92-	FA4440	FO962	FOC1059		FO346 FA830	H ES
22.210 - Cummins 6CT	01/88-	FA4650/1		FOC72/2		FO346 FA840	H ES
Separador de água				FOC410			
Serie 23t							
23.210 - Cummins 6BTAA	05/02-	FA9839	FO280	FOC72/2		FO346 FA839 FRA33	H ES Refr.
Separador de água - 2R0127177				FOC970/1			
23.210 - MWM 6.10 TCA	05/02-	FA9839	FO339			FO346 FA839	H ES
Separador de água				FOC970/1			
23.210 - Cummins 6CTAA	05/02-	FA9839		FOC72/2		FO346 FA839	H ES
Separador de água - para ref. original: 2R0127177				FOC970/1			
23.220 - Cummins 6CTAA	05/02-	FA9839		FOC72/2		FO346 FA839	H ES
Separador de água - para ref. original: 2R0127177				FOC970/1			
23.250 E - Cummins Int. 6 ISBE	01/04-	FA9839				FO346 FA839 FRA33	H ES Refr.
23.310 - Cummins 6CTAA	01/02-12/05	FA9839		FOC72/2		FO346 FA839 FRA33	H ES Refr.
Separador de água				FOC970/1			
Serie 24t							
24.220 - Cummins 6CTAA	01/91-12/99	FA5461		FOC72/2		FO346	H
Separador de água				FOC410			
24.220 - Cummins 6CTAA	01/00-	FA9839		FOC72/2		FO346 FA839	H ES
Separador de água	06/01-			FOC970/1			
24.250 - Cummins 6CTAA	05/92-02/00	FA5461		FOC72/2		FO346	H
Separador de água				FOC410			

filtro

183

CB - Câmbio
DH - Direção hidráulica
ES - Elemento de segurança

FAS - Filtro do ar seco
FC - Filtro do ar para cabine
H - Hidráulico

PC - Precarga
TR - Transmissão hidráulica
Refr. - Filtro de refrigeração



MODELO/ MOTOR		ar	óleo	combustível	cabine	diversos	tipo filtro
							

VOLKSWAGEN (cont.)

CAMINHÕES

Serie 24t

24.250 - Worker / Constellation - Cummins Int. 6 ISBE

07/03-

FA9839

FO346

H

FA839

ES

FRA33

Refr.

24.320 - Constellation - Cummins ISC Turbo Intercooler

01/09-

FA9839

FO346

H

FA839

ES

Serie 25t

25.320 - Constellation 6x2 - Cummins ISC Turbo Intercooler

01/08-

FA9839

FO346

H

FA839

ES

25.370 E - Constellation 6x2 - MWM Int. NGD 370

07/07-

FA9839

FO346

H

Serie 26t

26.220 - Worker - Cummins 6CTAA

11/01-

FA9839

FOC72/2

FO346

H

FA839

ES

Separador de água - para ref. original: 2R0127177

FOC970/1

26.260 - Cummins 6CTAA

02/02-

FA9839

FOC72/2

FO346

H

FA839

ES

Separador de água - para ref. original: 2R0127177

FOC970/1

26.260 E - Worker - MWM 6.12 TCE

12/05-

FA9839

FO339

FO346

H

FA839

ES

26.300 - Cummins 6CTAA

01/00-

FA9839

FOC72/2

FO346

H

FA839

ES

Separador de água

06/01-

FOC970/1

26.310 - Titan - Cummins 6CTAA

11/01-

FA9839

FOC72/2

FO346

H

FA839

ES

Separador de água - para ref. original: 2R0127177

FOC970/1

Serie 31t

31.260 - Cummins 6CTAA

10/04-

FA9839

FO346

H

FA839

ES

Separador de água - para ref. original 2R0127177

FOC970/1

31.260 E - Worker - MWM 6.12 TCE

12/05-

FA9839

FO339

FO346

H

FA839

ES

31.310 - Cummins 6CTAA

10/04-

FA9839

FOC72/2

FO346

H

FA839

ES

Separador de água - para ref. original: 2R0127177

FOC970/1

31.320 E - Constellation 6x4 - Cummins ISC

02/07-

FA9839

FO346

H

31.370 E - Constellation 6x4 - MWM Int. NGD 370

07/07-

FA9839

FO346

H

Serie 35t

35.300 - Cummins 6CTAA

04/91-

FA5461

FOC72/2

FO346

H

Separador de água

FOC410

Serie 40t

40.300 - Cummins 6CTAA

06/99-11/01

FOC72/2

FO346

H

-02/00

FA5461

FOC410

03/00-

FA9839

FA839

ES

Separador de água - para ref. original: 2R0127177

FOC970/1

ÔNIBUS

Serie 5

5.140 - MWM 4.08 TCE

07/05-

FA7998

FO340

FO346

H

FA820

ES

Serie 8

8.120 OD - MWM 4.10 TCA

04/03-

FA7998

FO962

FO346

H

FA820

ES

Separador de água

FOC970/1



Linha de produtos Magneti Marelli
Filtro ar, óleo, cabine e combustível



MODELO/ MOTOR		ar	óleo	combustível	cabine	diversos	tipo filtro

VOLKSWAGEN (cont.)

ÔNIBUS

Serie 8

8.150 OD - MWM 4.10 TCA

04/03-

FA7998

FO962

FOC970/1

FO346

FA820

H

ES

Separador de água

8.150 EOD - MWM 4.08 TCE

07/05-

FA7998

FO340

FO346

FA820

H

ES

8.150 EOD - MWM 4.12 TCAE

04/04-

FA7998

FO962

FO346

FA820

H

ES

8.150 EOD - Cummins Int. 4 ISBE

01/04-

FA7998

FO346

FA820

H

ES

Serie 9

9.150 OD - MWM 4.12 TCA

04/03-

FA7998

FO962

FOC970/1

FO346

FA820

H

ES

Separador de água

9.150 E OD - MWM 4.12 TCAE

04/04-

FA7998

FO962

FO346

FA820

H

ES

9.150 E OD - Cummins Int. 4 ISBE

01/04-

FA7998

FO346

FA820

H

ES

Serie 15

15.180 E OD - MWM 6.12 TCAE

04/04-

FA9839

FO339

FO346

FA839

H

ES

15.180 E OD - MWM 4.12 TCAE

11/04-

FA9839

FO339

FO346

FA839

H

ES

15.190 EOD - MWM 4.12 TCE EuroIII

04/04-

FA9839

FO962

FO346

FA839

H

ES

Serie 16

16.180 CO - MWM 6.10

03/93-06/97

FA9834

FO339

FOC72/2

FO346

FA820

H

ES

Separador de água

FOC460/1

16.210 CO - MWM 6.10

06/97-08/01

FA9834

FO339

FOC72/2

FO346

FA820

H

ES

Separador de água

FOC460/1

Serie 17

17.210 E OD - MWM 6.10 TCA

09/01-

FA9834

FO339

FO346

FA820

H

ES

Separador de água

FOC460/1

17.210 E OD - MWM 4.12 TCAE

04/04-

FA9839

FO962

FO346

FA839

H

ES

17.210 E OD - MWM 6.12 TCAE

12/05-

FA9839

FO339

FO346

FA839

H

ES

17.230 EOD - MWM 6.12 TCE EuroIII

04/04-

FA9839

FO339

FO346

FA839

H

ES

17.230 EOD V-Tronic - MWM 6.12 TCE - Euro III

01/08-

FA9839

FO339

FA839

ES

17.240 OT - MWM 6.10 TCA

03/01-

FA9839

FO339

FO346

FA839

H

ES

Separador de água

FOC460/1

17.240 OT - Cummins 6CTAA

06/03-

FA9839

FOC72/2

FO346

FA839

H

ES

Separador de água

FOC460/1

17.260 E OT - MWM 6.12 TCAE

04/04-

FA9839

FO339

FO346

FA839

H

ES

17.260 EOT V-Tronic - MWM 6.12 TCE - Euro III

01/08-

FA9839

FO339

FA839

ES

CB - Câmbio
DH - Direção hidráulica
ES - Elemento de segurança

FAS - Filtro do ar seco
FC - Filtro do ar para cabine
H - Hidráulico

PC - Precarga
TR - Transmissão hidráulica
Refr. - Filtro de refrigeração

filtro

185



MODELO/ MOTOR		ar	óleo	combustível	cabine	diversos	tipo filtro
							

VOLKSWAGEN (cont.)

ÔNIBUS

Serie 18

18.310 OT - Cummins 6CTAA

06/03-

FA9839

FOC72/2

FO346

H

FA839

ES

Separador de água

FOC460/1

18.320 E OT - MWM 6.12 TCAE

04/04-

FA9839

FO339

FO346

H

FA839

ES

18.320 E OT - Cummins ISC 320

03/06-

FA9839

FO346

H

FA839

ES

linha de
produtos

MAGNET
MARET

**lâmpadas
automotivas**



Linha de produtos Magneti Marelli Lâmpadas automotivas



Modelo Ano Farol baixo Farol alto Nebl.diant. Lant.diant. Pisca dian. Pisca later. Lant. tras. Pisca tras. Luz freio Nebl. tras. Luz de ré Luz placa Luz painel Luz teto

AGRALE

6000 E-MEC	.../06	LMM64193	LMM64193		LMM7506	LMM7507		LMM7506	LMM7507	LMM7528		LMM7506	LMM2821	LMM3893	LMM3893
8500 E-MEC	.../06	LMM64193	LMM64193		LMM7506	LMM7507		LMM7506	LMM7507	LMM7528		LMM7506	LMM2821	LMM3893	LMM3893
8500 CD E-MEC	.../06	LMM64193	LMM64193		LMM7506	LMM7507		LMM7506	LMM7507	LMM7528		LMM7506	LMM2821	LMM3893	LMM3893
8500 E-TRONIC	.../06	LMM64193	LMM64193		LMM7506	LMM7507		LMM7506	LMM7507	LMM7528		LMM7506	LMM2821	LMM3893	LMM3893
9200 E-TRONIC	.../06	LMM64150	LMM64150		LMM7506	LMM7507		LMM7506	LMM7507	LMM7528		LMM7506	LMM2821	LMM3893	LMM3893
FURGOVAN 6000 E-TRONIC	.../06	LMM64210	LMM64210		LMM2825	LMM7507		LMM7506	LMM7507	LMM7528		LMM7506	LMM2821	LMM3893	LMM3893
FURGOVAN 8000 E-TRONIC	.../06	LMM64210	LMM64210		LMM2825	LMM7507		LMM7506	LMM7507	LMM7528		LMM7506	LMM2821	LMM3893	LMM3893

FORD

815	.../00	LMM64193	LMM64193		LMM7506	LMM7506		LMM7506	LMM7507	LMM7506		LMM7240			LMM6461
815	01/...	LMM64210	LMM64210		LMM7506	LMM7506		LMM7506	LMM7507	LMM7506		LMM7240			LMM6461
2422	00/...	LMM64210	LMM64210		LMM7506	LMM7506		LMM7506	LMM7507	LMM7506		LMM7240			LMM6461
4331	03/...	LMM64210	LMM64210		LMM7506	LMM7506		LMM7506	LMM7507	LMM7506		LMM7240			LMM6461
COURIER	94-05	LMM64193	LMM64193	LMM64150	LMM2825	LMM7507		LMM5007	LMM7507	LMM7506	LMM7506	LMM2825			LMM6461
CARGO 1722	02/...	LMM64210	LMM64210		LMM2825	LMM7506		LMM7528	LMM7506	LMM7506	LMM7506	LMM5007			LMM3893
CARGO 2422	04/...	LMM64210	LMM64210		LMM2825	LMM7506		LMM7528	LMM7506	LMM7506	LMM7506	LMM5007			LMM3893
CARGO 2428	05/...	LMM64210	LMM64210		LMM2825	LMM7506		LMM7528	LMM7506	LMM7506	LMM7506	LMM5007			LMM3893
CARGO 2622	03/...	LMM64210	LMM64210		LMM2825	LMM7506		LMM7528	LMM7506	LMM7506	LMM7506	LMM5007			LMM3893
CARGO 2628	06/...	LMM64210	LMM64210		LMM2825	LMM7506		LMM7528	LMM7506	LMM7506	LMM7506	LMM5007			LMM3893
CARGO 1317	02/...	LMM64210	LMM64210		LMM2825	LMM7506		LMM7528	LMM7506	LMM7506	LMM7506	LMM5007			LMM3893
CARGO 1517	02/...	LMM64210	LMM64210		LMM2825	LMM7506		LMM7528	LMM7506	LMM7506	LMM7506	LMM5007			LMM3893
CARGO 1717	02/...	LMM64210	LMM64210		LMM2825	LMM7506		LMM7528	LMM7506	LMM7506	LMM7506	LMM5007			LMM3893
CARGO 2632	04/...	LMM64215	LMM64215		LMM2825	LMM7511		LMM7537	LMM7511	LMM7511	LMM7511	LMM5627			LMM3930
CARGO 2932	06/...	LMM64215	LMM64215		LMM2825	LMM7511		LMM7537	LMM7511	LMM7511	LMM7511	LMM5627			LMM3930
CARGO 4432	06/...	LMM64215	LMM64215		LMM2825	LMM7511		LMM7537	LMM7511	LMM7511	LMM7511	LMM5627			LMM3930
CARGO 5032	06/...	LMM64215	LMM64215		LMM2825	LMM7511		LMM7537	LMM7511	LMM7511	LMM7511	LMM5627			LMM3930
F-1000	88-97	LMM64193	LMM64193		LMM2825	LMM7506		LMM7528	LMM7506	LMM7506	LMM7528	LMM5007			
F-100	00-04	LMM64193	LMM64193		LMM2825	LMM7506		LMM2825	LMM7506	LMM7506	LMM7506	LMM5007			
F-250	00-04	LMM64193	LMM64193		LMM2825	LMM7506		LMM2825	LMM7506	LMM7506	LMM7506	LMM5007			
F-350	00-04	LMM64193	LMM64193		LMM2825	LMM7506		LMM2825	LMM7506	LMM7506	LMM7506	LMM5007			
F-1250	98/...	LMM9007	LMM9007		LMM2825	LMM7506		LMM2825	LMM7506	LMM7506	LMM7506	LMM5007			
F-12000	.../05	LMM64210	LMM64210		LMM2825	LMM7506		LMM7528	LMM7506	LMM7506	LMM7506	LMM5007			LMM3893
F-14000	.../05	LMM64210	LMM64210		LMM2825	LMM7506		LMM7528	LMM7506	LMM7506	LMM7506	LMM5007			LMM3893
F-16000	.../05	LMM64210	LMM64210		LMM2825	LMM7506		LMM7528	LMM7506	LMM7506	LMM7506	LMM5007			LMM3893
F-4000	88-97	LMM64193	LMM64193		LMM2825	LMM7506		LMM7528	LMM7506	LMM7506	LMM7528	LMM5007			

IVECO

CITY CLASS	04/...	LMM64193	LMM64193		LMM7506		LMM5007	LMM7506	LMM7506	LMM2825	LMM7506	LMM7506	LMM5007		
DAILY I	78-99	LMM64193	LMM64151		LMM7506		LMM5007	LMM7506	LMM7506	LMM2825	LMM7506	LMM7506	LMM5007		
DAILY II	99/...	LMM64150	LMM64150		LMM7506		LMM5007	LMM7506	LMM7506	LMM7506	LMM7506	LMM7506	LMM5007		
EUROCARGO	91/...	LMM64196	LMM64156				LMM5627	LMM7511	LMM7511	LMM7511	LMM7511	LMM7511	LMM5627		
EUROSTAR	02/...	LMM64196 LMM64156	LMM64156		LMM3930		LMM5627	LMM7511	LMM7511	LMM7511	LMM7511	LMM7511	LMM5627		
EUROTECH MH	98/...	LMM64196	LMM64156		LMM7511		LMM5627	LMM7511	LMM7511	LMM7511	LMM7511	LMM7511	LMM5627		
EUROTECH MP	92/...	LMM64196	LMM64156		LMM7511		LMM5627	LMM7511	LMM7511	LMM7511	LMM7511	LMM7511	LMM5627		
MAXIVAN	03/...	LMM64193	LMM64193		LMM7506		LMM5007	LMM7506	LMM7506	LMM2825	LMM7506	LMM7506	LMM5007		
SCUDATO	02/...	LMM64193	LMM64193		LMM7506		LMM5007	LMM7506	LMM7506	LMM2825	LMM7506	LMM7506	LMM5007		
STRALIS	02/...	LMM64215	LMM64155		LMM9507		LMM5627	LMM7511	LMM7511	LMM7511	LMM7511	LMM7511	LMM5637		
TRAKKER	93-04	LMM64196			LMM7511		LMM5627	LMM7511	LMM7511	LMM7511	LMM7511	LMM7511	LMM5637		

KIA MOTORS

BESTA	96/...	LMM64193	LMM64193		LMM3893	LMM7506		LMM7528	LMM7506	LMM7528	LMM7506	LMM2825		LMM6461	
BONGO	05/...	LMM64193	LMM64193		LMM2825	LMM7506		LMM7528	LMM7506	LMM7528	LMM7528	LMM2825		LMM6461	

MERCEDES-BENZ

311	02-05	LMM64150	LMM64210		LMM2825	LMM7506	LMM2825 LMM2827	LMM7506	LMM7506	LMM7506		LMM7528	LMM2825		
313	05/...	LMM64150	LMM64210		LMM2825	LMM7506	LMM2825 LMM282	LMM7506	LMM7506	LMM7506		LMM7528	LMM2825		
413	05/...	LMM64150	LMM64210		LMM2825	LMM7506	LMM2825 LMM2827	LMM7506	LMM7506	LMM7506		LMM7528	LMM2825		
608	.../96	LMM7951 LMM64193	LMM64193		LMM3893	LMM7506		LMM5007	LMM7506	LMM7506		LMM7506	LMM5007		
708	87-89	LMM7951 LMM64193	LMM64193		LMM3893	LMM7506		LMM5007	LMM7506	LMM7506		LMM7506	LMM5007		



Modelo Ano Farol baixo Farol alto Nebl.diant. Lant.diant. Pisca dian. Pisca later. Lant.tras. Pisca tras. Luz freio Nebl. tras. Luz de ré Luz placa Luz painel Luz teto

MERCEDES-BENZ (cont.)

709	90-96	LMM7951 LMM64193	LMM64193		LMM3893	LMM7506		LMM5007	LMM7506	LMM7506		LMM7506	LMM5007		
710	97...	LMM7951 LMM64193	LMM64193		LMM3893	LMM7506		LMM5007	LMM7506	LMM7506		LMM7506	LMM5007		
712	97-02	LMM7951 LMM64193	LMM64193		LMM3893	LMM7506		LMM5007	LMM7506	LMM7506		LMM7506	LMM5007		
715	03-05	LMM64215	LMM64155		LMM2845	LMM7537		LMM7511	LMM7511	LMM7511		LMM7537	LMM2845	LMM5637	
715	03-05	LMM64210	LMM64150		LMM2825	LMM7528		LMM7506	LMM7506	LMM7506		LMM7528	LMM2825	LMM5008	
809	90-96	LMM7951 LMM64193	LMM64193		LMM3893	LMM7506		LMM5007	LMM7506	LMM7506		LMM7506	LMM5007		
812	97-02	LMM7951 LMM64193	LMM64193		LMM3893	LMM7506		LMM5007	LMM7506	LMM7506		LMM7506	LMM5007		
814	02/...	LMM7951 LMM64193	LMM64193		LMM3893	LMM7506		LMM5007	LMM7506	LMM7506		LMM7506	LMM5007		
912	90-96	LMM7951 LMM64193	LMM64193		LMM3893	LMM7506		LMM5007	LMM7506	LMM7506		LMM7506	LMM5007		
914	97-02	LMM7951 LMM64193	LMM64193		LMM3893	LMM7506		LMM5007	LMM7506	LMM7506		LMM7506	LMM5007		
915	03/...	LMM64215	LMM64155		LMM2845	LMM7537		LMM7511	LMM7511	LMM7511		LMM7537	LMM2845	LMM5637	
1111	85-86	LMM7951			LMM5008	LMM7528		LMM7528	LMM7528	LMM7528		LMM5007	LMM3796	LMM7533	
1113	85-86	LMM7951			LMM5008	LMM7528		LMM7528	LMM7528	LMM7528		LMM5007	LMM3796	LMM7533	
1114	85-86	LMM7951			LMM5008	LMM7528		LMM7528	LMM7528	LMM7528		LMM5007	LMM3796	LMM7533	
1115	90-97	LMM64193	LMM64193	LMM64150	LMM3893	LMM7506		LMM5007	LMM7506	LMM7506		LMM7506	LMM5007	LMM2721 LMM3796 LMM2821	LMM7506
1116	90-97	LMM64193	LMM64193	LMM64150	LMM3893	LMM7506		LMM5007	LMM7506	LMM7506		LMM7506	LMM5007	LMM2721 LMM3796 LMM2821	LMM7506
1117	90-97	LMM64193	LMM64193	LMM64150	LMM3893	LMM7506		LMM5007	LMM7506	LMM7506		LMM7506	LMM5007	LMM2721 LMM3796 LMM2821	LMM7506
1118	90-97	LMM64193	LMM64193	LMM64150	LMM3893	LMM7506		LMM5007	LMM7506	LMM7506		LMM7506	LMM5007	LMM2721 LMM3796 LMM2821	LMM7506
1214	85-86	LMM7951			LMM5008	LMM7528		LMM7528	LMM7528	LMM7528		LMM5007	LMM3796	LMM7533	
1215	85-86	LMM7951			LMM5008	LMM7528		LMM7528	LMM7528	LMM7528		LMM5007	LMM3796	LMM7533	
1218	90-97	LMM64193	LMM64193	LMM64150	LMM3893	LMM7506		LMM5007	LMM7506	LMM7506		LMM7506	LMM5007	LMM2721 LMM3796 LMM2821	LMM7506
1313	85-86	LMM7951			LMM5008	LMM7528		LMM7528	LMM7528	LMM7528		LMM5007	LMM3796	LMM7533	
1313	77-84	LMM7951			LMM7506	LMM7506		LMM7506	LMM7528	LMM7506		LMM7506	LMM6418	LMM3796	LMM6418
1314	90-97	LMM64193	LMM64193	LMM64150	LMM3893	LMM7506		LMM5007	LMM7506	LMM7506		LMM7506	LMM5007	LMM2721 LMM3796 LMM2821	LMM7506
1316	90-97	LMM64193	LMM64193	LMM64150	LMM3893	LMM7506		LMM5007	LMM7506	LMM7506		LMM7506	LMM5007	LMM2721 LMM3796 LMM2821	LMM7506
1317	90-97	LMM64193	LMM64193	LMM64150	LMM3893	LMM7506		LMM5007	LMM7506	LMM7506		LMM7506	LMM5007	LMM2721 LMM3796 LMM2821	LMM7506
1318	90-97	LMM64193	LMM64193	LMM64150	LMM3893	LMM7506		LMM5007	LMM7506	LMM7506		LMM7506	LMM5007	LMM2721 LMM3796 LMM2821	LMM7506
1319	90-97	LMM64193	LMM64193	LMM64150	LMM3893	LMM7506		LMM5007	LMM7506	LMM7506		LMM7506	LMM5007	LMM2721 LMM3796 LMM2821	LMM7506
1414	90-97	LMM64193	LMM64193	LMM64150	LMM3893	LMM7506		LMM5007	LMM7506	LMM7506		LMM7506	LMM5007	LMM2721 LMM3796 LMM2821	LMM7506
1418	90-97	LMM64193	LMM64193	LMM64150	LMM3893	LMM7506		LMM5007	LMM7506	LMM7506		LMM7506	LMM5007	LMM2721 LMM3796 LMM2821	LMM7506
1513	77-84	LMM7951			LMM7506	LMM7506		LMM7506	LMM7528	LMM7506		LMM7506	LMM6418	LMM3796	LMM6418
1514	77-84	LMM7951			LMM7506	LMM7506		LMM7506	LMM7528	LMM7506		LMM7506	LMM6418	LMM3796	LMM6418
1516	77-84	LMM7951			LMM7506	LMM7506		LMM7506	LMM7528	LMM7506		LMM7506	LMM6418	LMM3796	LMM6418
1517	90-97	LMM64150	LMM64193		LMM3893	LMM7506		LMM5007	LMM7506	LMM7506		LMM7506	LMM5007	LMM2721 LMM3796 LMM2821	LMM7506
1518	77-84	LMM64193			LMM7506	LMM7506		LMM7506	LMM7528	LMM7506		LMM7506	LMM6418	LMM3796	LMM6418
1519	77-84	LMM64150	LMM64193		LMM7506	LMM7506		LMM5007	LMM7506	LMM7506		LMM7506	LMM6418	LMM3796	LMM6418
1520	77-84	LMM64150	LMM64193		LMM7506	LMM7506		LMM5007	LMM7506	LMM7506		LMM7506	LMM6418	LMM3796	LMM6418

190

lâmpadas automotivas



Linha de produtos Magneti Marelli

Lâmpadas automotivas



Modelo Ano Farol baixo Farol alto Nebl.diant. Lant.diant. Pisca dian. Pisca later. Lant. tras. Pisca tras. Luz freio Nebl. tras. Luz de ré Luz placa Luz painel Luz teto

MERCEDES-BENZ (cont.)

1524	77-84	LMM64150	LMM64193		LMM7506	LMM7506		LMM5007	LMM7506	LMM7506		LMM7506	LMM6418	LMM3796	LMM6418
1525	77-84	LMM64150	LMM64193		LMM7506	LMM7506		LMM5007	LMM7506	LMM7506		LMM7506	LMM6418	LMM3796	LMM6418
1614	77-84	LMM64193			LMM7506	LMM7506		LMM7506	LMM7528	LMM7506		LMM7506	LMM6418	LMM3796	LMM6418
1617	90-97	LMM64150	LMM64193		LMM3893	LMM7506		LMM5007	LMM7506	LMM7506		LMM7506	LMM5007	LMM3796 LMM2821	LMM7506
1618	90-97	LMM64150	LMM64193		LMM3893	LMM7506		LMM5007	LMM7506	LMM7506		LMM7506	LMM5007	LMM3796 LMM2821	LMM7506
1620	90-97	LMM64150	LMM64193		LMM3893	LMM7506		LMM5007	LMM7506	LMM7506		LMM7506	LMM5007	LMM3796 LMM2821	LMM7506
1621	90-97	LMM64150	LMM64193		LMM3893	LMM7506		LMM5007	LMM7506	LMM7506		LMM7506	LMM5007 LMM2721	LMM3796	LMM7506
1622	90-97	LMM64150	LMM64193		LMM3893	LMM7506		LMM5007	LMM7506	LMM7506		LMM7506	LMM5007 LMM2821	LMM3796 LMM7506	
1625	90-97	LMM64150	LMM64193		LMM3893	LMM7506		LMM5007	LMM7506	LMM7506		LMM7506	LMM5007	LMM3796 LMM2821	LMM7506
1630	90-97	LMM64150	LMM64193		LMM3893	LMM7506		LMM5007	LMM7506	LMM7506		LMM7506	LMM5007	LMM3796 LMM2821	LMM7506
1632	90-97	LMM64150	LMM64193		LMM3893	LMM7506		LMM5007	LMM7506	LMM7506		LMM7506	LMM5007	LMM3796 LMM2821	LMM7506
1714	90-97	LMM64150	LMM64193		LMM3893	LMM7506		LMM5007	LMM7506	LMM7506		LMM7506	LMM5007	LMM3796 LMM2821	LMM7506
1718	90-97	LMM64150	LMM64193		LMM3893	LMM7506		LMM5007	LMM7506	LMM7506		LMM7506	LMM5007	LMM3796 LMM2821	LMM7506
1720	90-97	LMM64150	LMM64193		LMM3893	LMM7506		LMM5007	LMM7506	LMM7506		LMM7506	LMM5007	LMM3796 LMM2821	LMM7506
1721	90-97	LMM64150	LMM64193		LMM3893	LMM7506		LMM5007	LMM7506	LMM7506		LMM7506	LMM5007	LMM3796 LMM2821	LMM7506
1723	90-97	LMM64150	LMM64193		LMM3893	LMM7506		LMM5007	LMM7506	LMM7506		LMM7506	LMM5007	LMM3796 LMM2821	LMM7506
1741	90-97	LMM64150	LMM64193		LMM3893	LMM7506		LMM5007	LMM7506	LMM7506		LMM7506	LMM5007	LMM3796 LMM2821	LMM7506
1825	90-97	LMM64150	LMM64193		LMM3893	LMM7506		LMM5007	LMM7506	LMM7506		LMM7506	LMM5007	LMM3796 LMM2821	LMM7506
1924	76-84	LMM7952			LMM7511	LMM7511		LMM7511		LMM7511		LMM7511	LMM6423	LMM3797	LMM6423
1929	76-84	LMM7952			LMM7511	LMM7511		LMM7511		LMM7511		LMM7511	LMM6423	LMM3797	LMM6423
1929	85-86	LMM7952			LMM5637	LMM7511		LMM7511		LMM7511		LMM7511	LMM5627	LMM3797	
1930	76-84	LMM7952			LMM7511	LMM7511		LMM7511		LMM7511		LMM7511	LMM6423	LMM3797	LMM6423
1932	76-84	LMM7952			LMM7511	LMM7511		LMM7511		LMM7511		LMM7511	LMM6423	LMM3797	LMM6423
1932	85-86	LMM7952			LMM5637	LMM7511		LMM7511		LMM7511		LMM7511	LMM5627	LMM3797	
1933	76-84	LMM7952			LMM7511	LMM7511		LMM7511		LMM7511		LMM7511	LMM6423	LMM3797	LMM6423
1934	76-84	LMM7952			LMM7511	LMM7511		LMM7511		LMM7511		LMM7511	LMM6423	LMM3797	LMM6423
1935	76-84	LMM7952			LMM7511	LMM7511		LMM7511		LMM7511		LMM7511	LMM6423	LMM3797	LMM6423
1938	90-97	LMM64150	LMM64193		LMM3893	LMM7506		LMM5007	LMM7506	LMM7506		LMM7506	LMM5007	LMM3796 LMM2821	LMM7506
1940	90-97	LMM64150	LMM64193		LMM3893	LMM7506		LMM5007	LMM7506	LMM7506		LMM7506	LMM5007	LMM3796 LMM2821	LMM7506
1941	90-97	LMM64150	LMM64193		LMM3893	LMM7506		LMM5007	LMM7506	LMM7506		LMM7506	LMM5007	LMM3796 LMM2821	LMM7506
2013	77-84	LMM7951			LMM7506	LMM7506		LMM7506	LMM7528	LMM7506		LMM7506	LMM6418	LMM3796	LMM6418
2014	77-84	LMM7951			LMM7506	LMM7506		LMM7506	LMM7528	LMM7506		LMM7506	LMM6418	LMM3796	LMM6418
2017	77-84	LMM7951			LMM7506	LMM7506		LMM7506	LMM7528	LMM7506		LMM7506	LMM6418	LMM3796	LMM6418
2035	77-84	LMM64215	LMM64155		LMM2845	LMM7537		LMM7511	LMM7511	LMM7511		LMM7537	LMM2845	LMM5637	
2040	77-84	LMM64215	LMM64155		LMM2845	LMM7537		LMM7511	LMM7511	LMM7511		LMM7537	LMM2845	LMM5637	
2044	77-84	LMM64215	LMM64155		LMM2845	LMM7537		LMM7511	LMM7511	LMM7511		LMM7537	LMM2845	LMM5637	
2213	77-84	LMM7951			LMM7506	LMM7506		LMM7506	LMM7528	LMM7506		LMM7506	LMM6418	LMM3796	LMM6418



Modelo Ano Farol baixo Farol alto Nebl.diant. Lant.diant. Pisca dian. Pisca later. Lant.tras. Pisca tras. Luz freio Nebl. tras. Luz de ré Luz placa Luz painel Luz teto

MERCEDES-BENZ (cont.)

2214	77-84	LMM7951				LMM7506	LMM7506			LMM7506	LMM7528	LMM7506		LMM7506	LMM6418	LMM3796	LMM6418
2215	77-84	LMM7951				LMM7506	LMM7506			LMM7506	LMM7528	LMM7506		LMM7506	LMM6418	LMM3796	LMM6418
2216	77-84	LMM7951				LMM7506	LMM7506			LMM7506	LMM7528	LMM7506		LMM7506	LMM6418	LMM3796	LMM6418
2217	77-84	LMM7951				LMM7506	LMM7506			LMM7506	LMM7528	LMM7506		LMM7506	LMM6418	LMM3796	LMM6418
2219	85-90	LMM64150	LMM64193			LMM7506	LMM7506			LMM5007	LMM7506	LMM7506		LMM7506	LMM6418	LMM3796	LMM6418
2220	85-90	LMM64150	LMM64193			LMM7506	LMM7506			LMM5007	LMM7506	LMM7506		LMM7506	LMM6418	LMM3796	LMM6418
2225	85-90	LMM64150	LMM64193			LMM7506	LMM7506			LMM5007	LMM7506	LMM7506		LMM7506	LMM6418	LMM3796	LMM6418
2314	90-97	LMM64150	LMM64193			LMM3893	LMM7506			LMM5007	LMM7506	LMM7506		LMM7506	LMM5007	LMM2721 LMM3796 LMM2821	LMM7506
2318	90-97	LMM64150	LMM64193			LMM3893	LMM7506			LMM5007	LMM7506	LMM7506		LMM7506	LMM5007	LMM2721 LMM3796 LMM2821	LMM7506
2325	90-97	LMM64150	LMM64193			LMM3893	LMM7506			LMM5007	LMM7506	LMM7506		LMM7506	LMM6418	LMM3796	LMM6418
2414	90-97	LMM64150	LMM64193			LMM3893	LMM7506			LMM5007	LMM7506	LMM7506		LMM7506	LMM5007	LMM2721 LMM3796 LMM2821	LMM7506
2418	90-97	LMM64150	LMM64193			LMM3893	LMM7506			LMM5007	LMM7506	LMM7506		LMM7506	LMM5007 LMM2721	LMM3796	LMM7506
2423	90-97	LMM64150	LMM64193			LMM3893	LMM7506			LMM5007	LMM7506	LMM7506		LMM7506	LMM5007	LMM3796 LMM2821	LMM7506
2425	03/...	LMM64150	LMM64193			LMM3893	LMM7506			LMM5007	LMM7506	LMM7506		LMM7506	LMM6418	LMM3796	LMM6418
2533	04/...	LMM64150	LMM64193			LMM3893	LMM7506			LMM5007	LMM7506	LMM7506		LMM7506	LMM6418	LMM3796	LMM6418
2540	05/...	LMM64150	LMM64193			LMM3893	LMM7506			LMM5007	LMM7506	LMM7506		LMM7506	LMM6418	LMM3796	LMM6418
2544	05/...	LMM64150	LMM64193			LMM3893	LMM7506			LMM5007	LMM7506	LMM7506		LMM7506	LMM6418	LMM3796	LMM6418
2635	90-97	LMM64150	LMM64193			LMM3893	LMM7506			LMM5007	LMM7506	LMM7506		LMM7506	LMM5007	LMM2721 LMM3796 LMM2821	LMM7506
2638	90-97	LMM64150	LMM64193			LMM3893	LMM7506			LMM5007	LMM7506	LMM7506		LMM7506	LMM5007	LMM2721 LMM3796 LMM23821	LMM7506
2640	90-97	LMM64155	LMM64215	LMM64155	LMM2845	LMM7511		LMM5637	LMM7511	LMM7511		LMM7511		LMM7511			
2644	90-97	LMM64155	LMM64215	LMM64155	LMM2845	LMM7511		LMM5637	LMM7511	LMM7511		LMM7511		LMM7511			
3340	90-97	LMM64155	LMM64215	LMM64155	LMM2845	LMM7511		LMM5637	LMM7511	LMM7511		LMM7511		LMM7511			
3344	90-97	LMM64155	LMM64215	LMM64155	LMM2845	LMM7511		LMM5637	LMM7511	LMM7511		LMM7511		LMM7511			
4140	90-97	LMM64155	LMM64215	LMM64155	LMM2845	LMM7511		LMM5637	LMM7511	LMM7511		LMM7511		LMM7511			
4144	90-97	LMM64155	LMM64215	LMM64155	LMM2845	LMM7511		LMM5637	LMM7511	LMM7511		LMM7511		LMM7511			
ACTROS	2003	LMM64156	LMM64155		LMM2845	LMM9507		LMM5637	LMM7511	LMM7511	LMM7511	LMM7511	LMM7537	LMM7511	LMM5637		
AXOR	2003	LMM64155	LMM64196 LMM64156		LMM2845	LMM7511		LMM5637	LMM7511	LMM7511	LMM7511	LMM7511	LMM7537	LMM7511	LMM5637		
CAMINHÃO MÉDIO ÔNIBUS	87-89	LMM7951 LMM64193	LMM64193		LMM3893	LMM7506		LMM5008	LMM7506	LMM7506		LMM7506	LMM5008	LMM3796	LMM7533		
CAMINHÃO PESADO ÔNIBUS	87-89	LMM64155	LMM64196		LMM3930	LMM7511		LMM5637	LMM7511				LMM5637	LMM3797			
CAMINHÃO PESADO ÔNIBUS	90-94	LMM64155	LMM64196		LMM3930	LMM7511		LMM5627	LMM7511	LMM7511		LMM7511	LMM5627	LMM2741 LMM2841 LMM3797	LMM7511		
CAMINHÃO SEMI-PESADO MÉDIO ÔNIBUS	90-97	LMM64150	LMM64193		LMM3893	LMM7506		LMM5007	LMM7506	LMM7506		LMM7506	LMM5007	LMM2721 LMM3796 LMM2821	LMM7506		
CAMINHÃO LEVE ÔNIBUS	85-89	LMM7951 LMM64193	LMM64193			LMM7506		LMM5008	LMM7506	LMM7506		LMM7506	LMM5008	LMM2721 LMM3796	LMM7506		
CITARO	98/...	LMM64156			LMM3930	LMM9507		LMM7537		LMM7511	LMM7537	LMM7511	LMM7511	LMM6423			
CONECTO	01/...				LMM2845			LMM5637	LMM7511	LMM7511	LMM7511	LMM7511	LMM7511	LMM6423			
ECONIC	98/...	LMM64155	LMM64156		LMM3930	LMM7511		LMM5637	LMM7511	LMM7511	LMM7511	LMM7511	LMM7511				
L 1620	96/...	LMM64150	LMM64193		LMM2825	LMM7506		LMM5007	LMM7506	LMM7506	LMM7506	LMM7506	LMM5007	LMM2721 LMM3796 LMM2821	LMM7506		
L 1622	96/...	LMM64150	LMM64193		LMM2825	LMM7506		LMM5007	LMM7506	LMM7506	LMM7506	LMM7506	LMM5007	LMM2721 LMM3796 LMM2821	LMM7506		
L 608	77-84		LMM7951		LMM7506	LMM7506		LMM7506	LMM7506	LMM7506		LMM7506	LMM5008	LMM2721 LMM3796	LMM3893		
LO 702	96/...	LMM64210	LMM64150		LMM2825	LMM7225 LMM7528		LMM7506	LMM7506	LMM7506	LMM7528	LMM2825	LMM5008				
LO 812	96/...	LMM64210	LMM64150		LMM2825	LMM7225 LMM7528		LMM7506	LMM7506	LMM7506	LMM7528	LMM2825	LMM5008				
LO 915	96/...	LMM64210	LMM64150		LMM2825	LMM7225 LMM7528		LMM7506	LMM7506	LMM7506	LMM7528	LMM2825	LMM5008				
LS 1634	96/...	LMM64150	LMM64193		LMM3893	LMM7506		LMM5007	LMM7506	LMM7506	LMM7506	LMM6418	LMM3796	LMM6418			



Linha de produtos Magneti Marelli Lâmpadas automotivas

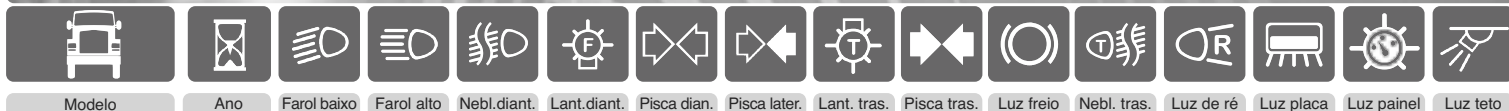

MERCEDES-BENZ (cont.)

LS 1938	96/...	LMM64150	LMM64193		LMM3893	LMM7506		LMM5007	LMM7506	LMM7506	LMM7506	LMM6418	LMM3796	LMM6418	
LS 2638	96/...	LMM64150	LMM64193		LMM3893	LMM7506		LMM5007	LMM7506	LMM7506	LMM7506	LMM6418	LMM3796	LMM6418	
MB 180	98/...	LMM64193	LMM64193		LMM2825	LMM7507	LMM2825	LMM5008	LMM7507	LMM7506	LMM7506	LMM2825			
MB 180	.../98	LMM64210	LMM64150		LMM2825	LMM7507	LMM2825	LMM7225	LMM7507	LMM7225	LMM7506	LMM2825			
MERCEDINHO	77-84		LMM7951		LMM7506	LMM7506		LMM7506	LMM7506	LMM7506		LMM7506	LMM5008	LMM2721 LMM3796	LMM6418 LMM3893
O 100	94/...		LMM64196	LMM64156	LMM2845	LMM7511		LMM5627	LMM7511	LMM7511	LMM7511	LMM7511	LMM7511	LMM6423	
O 340	91-95		LMM64196	LMM64156	LMM3930	LMM7511		LMM5637	LMM7511	LMM7511	LMM7511	LMM7511	LMM7511	LMM6423	
O 355	77-84		LMM7951		LMM7506	LMM7506		LMM7506	LMM7506	LMM7506		LMM7506	LMM5008	LMM2721 LMM3796	LMM6418 LMM3893
O 362	77-84		LMM7951		LMM7506	LMM7506		LMM7506	LMM7506	LMM7506		LMM7506	LMM5008	LMM2721 LMM3796	LMM6418 LMM3893
O 364	77-84		LMM7951		LMM7506	LMM7506		LMM7506	LMM7506	LMM7506		LMM7506	LMM5008	LMM2721 LMM3796	LMM6418 LMM3893
O 370	85-86		LMM7952		LMM5637	LMM7511					LMM7511	LMM5627	LMM3797		
O 371	90-97		LMM64196	LMM64196	LMM64155	LMM3930	LMM7511		LMM7511			LMM7511	LMM6423	LMM2741 LMM2841 LMM3797	LMM7511 LMM5627
O 400	90-97		LMM64215	LMM64196		LMM3930	LMM7511		LMM5637	LMM7511	LMM7511	LMM7511	LMM7511	LMM5637	
O 407	90-97		LMM64215	LMM64196		LMM3930	LMM7511		LMM5637	LMM7511	LMM7511	LMM7511	LMM7511	LMM5637	
O 500	90-97		LMM64215	LMM64196		LMM3930	LMM7511		LMM5637	LMM7511	LMM7511	LMM7511	LMM7511	LMM5637	
SPRINTER	90-94		LMM64150		LMM2825	LMM7507	LMM2825	LMM2825	LMM7507	LMM7506	LMM7506	LMM2825			
SPRINTER	95/...		LMM64150		LMM2825	LMM7507		LMM5007	LMM7506	LMM7506	LMM7506	LMM7506	LMM7506	LMM5007	
TOURINO	03/...		LMM64196		LMM2845	LMM9507				LMM7511	LMM7537	LMM7511	LMM7511	LMM6423	
TRAVEGO	99/...		LMM64155	LMM64155	LMM2845	LMM9507		LMM7537		LMM7511	LMM7537	LMM7511	LMM7511	LMM6423	
VARIO	99/...		LMM64155		LMM2845	LMM2845		LMM5637	LMM7511	LMM7511	LMM7511	LMM2845	LMM7511	LMM6423	
VIANO	99/...		LMM64193	LMM64193	LMM64151	LMM3893 LMM2825	LMM7507		LMM2825	LMM7506	LMM7506	LMM7506	LMM6418		
VITO	99/...		LMM64193	LMM64193	LMM64151	LMM3893 LMM2825	LMM7507		LMM2825	LMM7506	LMM7506	LMM7506	LMM6418		

PEUGEOT

BOXER	94/...	LMM64193	LMM64193	LMM64151	LMM2825	LMM7507	LMM2825	LMM7528	LMM7507	LMM7506	LMM7528	LMM2825		LMM2825	
PARTNER	96-00	LMM64193	LMM64193	LMM64151	LMM2825	LMM7507		LMM7528	LMM7507	LMM7506	LMM7528	LMM2825		LMM2825	

RENAULT

MASTER	96/...	LMM64193	LMM64193	LMM64150	LMM2825	LMM7507	LMM2825	LMM7528	LMM7506	LMM7506	LMM7506	LMM5008			
KANGOO	98/...	LMM64193	LMM64193	LMM64150	LMM2825	LMM7507	LMM2825	LMM7528	LMM7507	LMM7506	LMM7528	LMM5008			

SCANIA

BI/LS	75-85	LMM7951	LMM7951		LMM3930	LMM7529		LMM5627	LMM7511	LMM7511				LMM3797	LMM6423
C 114	95/...	LMM64196	LMM64196	LMM64155	LMM5627	LMM7511		LMM5627	LMM7511	LMM7511	LMM7511	LMM7511	LMM5627		
C 124	95/...	LMM64196	LMM64196	LMM64155	LMM5627	LMM7511		LMM5627	LMM7511	LMM7511	LMM7511	LMM7511	LMM5627		
C 144	95/...	LMM64196	LMM64196	LMM64155	LMM5627	LMM7511	LMM5627	LMM5627	LMM7511	LMM7511	LMM7511	LMM7511	LMM5627		
C 164	00/...	LMM64196	LMM64196	LMM64155	LMM5627	LMM7511		LMM5627	LMM7511	LMM7511	LMM7511	LMM7511	LMM5627		
C 94	95/...	LMM64196	LMM64196	LMM64155	LMM5627	LMM7511	LMM5627	LMM5627	LMM7511	LMM7511	LMM7511	LMM7511	LMM5627		
D 94	95/...	LMM64196	LMM64196	LMM64155	LMM5627	LMM7511	LMM5627	LMM5627	LMM7511	LMM7511	LMM7511	LMM7511	LMM5627		
E 143	88-96	LMM64196	LMM64196 LMM64156	LMM64156	LMM5627	LMM7511	LMM5627	LMM5627	LMM7511	LMM7511	LMM7511	LMM7511	LMM5627		
F 112	89/...	LMM64196	LMM64196	LMM64156	LMM5627	LMM7511		LMM5627	LMM7511	LMM7511		LMM7529	LMM7529		
F 113	89/...	LMM64196	LMM64196	LMM64156	LMM5627	LMM7511		LMM5627	LMM7511	LMM7511		LMM7529	LMM7529		
F 114	89/...	LMM64196	LMM64196	LMM64156	LMM5627	LMM7511		LMM5627	LMM7511	LMM7511		LMM7529	LMM7529		
F 94	89/...	LMM64196	LMM64196	LMM64156	LMM5627	LMM7511		LMM5627	LMM7511	LMM7511		LMM7529	LMM7529		
G 114	95/...	LMM64196	LMM64196	LMM64155	LMM5627	LMM7511		LMM5627	LMM7511	LMM7511	LMM7511	LMM7511	LMM5627		
G 124	95/...	LMM64196	LMM64196	LMM64155	LMM5627	LMM7511		LMM5627	LMM7511	LMM7511	LMM7511	LMM7511	LMM5627		
G 144	95/...	LMM64196	LMM64196	LMM64155	LMM5627	LMM7511	LMM5627	LMM5627	LMM7511	LMM7511	LMM7511	LMM7511	LMM5627		
G 164	00/...	LMM64196	LMM64196	LMM64155	LMM5627	LMM7511		LMM5627	LMM7511	LMM7511	LMM7511	LMM7511	LMM5627		
G 94	95/...	LMM64196	LMM64196	LMM64155	LMM5627	LMM7511	LMM5627	LMM5627	LMM7511	LMM7511	LMM7511	LMM7511	LMM5627		
H 93	88-96	LMM64196	LMM64196 LMM64156	LMM64156	LMM5627	LMM7511	LMM5627	LMM5627	LMM7511	LMM7511	LMM7511	LMM7511	LMM5627		
K 112	89/...	LMM64196	LMM64196	LMM64156	LMM5627	LMM7511		LMM5627	LMM7511	LMM7511		LMM7529	LMM7529		
K 113	89/...	LMM64196	LMM64196	LMM64156	LMM5627	LMM7511		LMM5627	LMM7511	LMM7511		LMM7529	LMM7529		
K 114	84/...	LMM64196 LMM7952	LMM64196 LMM7952		LMM3930 LMM3797	LMM7511 LMM5637		LMM7511	LMM5627	LMM7511					
K 124	84/...	LMM64196 LMM7952	LMM64196 LMM7952		LMM3930	LMM7511		LMM7511	LMM5627	LMM7511				LMM3797	LMM5637
K 270	84/...	LMM64196 LMM7952	LMM64196 LMM7952		LMM3930	LMM7511		LMM7511	LMM5627	LMM7511				LMM3797	LMM5637



Modelo Ano Farol baixo Farol alto Nebl.diant. Lant.diant. Pisca dian. Pisca later. Lant.tras. Pisca tras. Luz freio Nebl. tras. Luz de ré Luz placa Luz painel Luz teto

SCANIA (cont.)

K 94	84/...	LMM64196	LMM64196		LMM3930	LMM7511		LMM7511	LMM5627	LMM7511				LMM3797	LMM5637
L 113	89/...	LMM7952 LMM64196	LMM7952 LMM64196	LMM64156	LMM5627	LMM7511		LMM5627	LMM7511	LMM7511		LMM7529	LMM7529		
L 113	89-96	LMM64196	LMM64196 LMM64156	LMM64156	LMM5627	LMM7511	LMM5627	LMM5627	LMM7511	LMM7511	LMM7511	LMM7511	LMM5627		
L 114	95/...	LMM64196	LMM64196	LMM64155	LMM5627		LMM7511	LMM5627	LMM7511	LMM7511	LMM7511	LMM7511	LMM5627		
L 124	95/...	LMM64196	LMM64196	LMM64155	LMM5627		LMM7511	LMM5627	LMM7511	LMM7511	LMM7511	LMM7511	LMM5627		
L 144	95/...	LMM64196	LMM64196	LMM64155	LMM5627	LMM7511	LMM5627	LMM5627	LMM7511	LMM7511	LMM7511	LMM7511	LMM5627		
L 164	00/...	LMM64196	LMM64196	LMM64155	LMM5627	LMM7511		LMM5627	LMM7511	LMM7511	LMM7511	LMM7511	LMM5627		
L 94	89/...	LMM64196	LMM64196	LMM64156	LMM5627	LMM7511		LMM5627	LMM7511	LMM7511		LMM7529	LMM7529		
L 94	95/...	LMM64196	LMM64196	LMM64155	LMM5627	LMM7511	LMM5627	LMM5627	LMM7511	LMM7511	LMM7511	LMM7511	LMM5627		
L / LT	75-94	LMM7952	LMM7952		LMM3930	LMM7529		LMM5627	LMM7511	LMM7511			LMM3797	LMM5637	
LK / LKS / LKT	78-83	LMM7952	LMM7952		LMM3930	LMM7511		LMM5627	LMM7511	LMM7511			LMM3797		
M 113	88-96	LMM64196	LMM64196 LMM64156	LMM64156	LMM5627	LMM7511	LMM5627	LMM5627	LMM7511	LMM7511	LMM7511	LMM7511	LMM5627		
M 143	88-96	LMM64196	LMM64196 LMM64156	LMM64156	LMM5627	LMM7511	LMM5627	LMM5627	LMM7511	LMM7511	LMM7511	LMM7511	LMM5627		
M 93	88-96	LMM64196	LMM64196 LMM64156	LMM64156	LMM5627	LMM7511	LMM5627	LMM5627	LMM7511	LMM7511	LMM7511	LMM7511	LMM5627		
ÔNIBUS	88-94				LMM5627	LMM7511		LMM5627	LMM7511	LMM7511		LMM7511	LMM5627	LMM3797	LMM6423
P 114	84/...	LMM64196	LMM64196		LMM3930	LMM7511		LMM5627	LMM7511					LMM3797	LMM5637
P 124	84/...	LMM64196	LMM64196		LMM3930	LMM7511		LMM5627	LMM7511					LMM3797	LMM5637
P 230	84/...	LMM64196	LMM64196		LMM3930	LMM7511		LMM5627	LMM7511					LMM3797	LMM5637
P 270	84/...	LMM64196	LMM64196		LMM3930	LMM7511		LMM5627	LMM7511					LMM3797	LMM5637
P 310	84/...	LMM64196	LMM64196		LMM3930	LMM7511		LMM5627	LMM7511					LMM3797	LMM5637
P 330	84/...	LMM64196	LMM64196		LMM3930	LMM7511		LMM5627	LMM7511					LMM3797	LMM5637
P 340	84/...	LMM64196	LMM64196		LMM3930	LMM7511		LMM5627	LMM7511					LMM3797	LMM5637
P 360	84/...	LMM64196	LMM64196		LMM3930	LMM7511		LMM5627	LMM7511					LMM3797	LMM5637
P 400	84/...	LMM64196	LMM64196		LMM3930	LMM7511		LMM5627	LMM7511					LMM3797	LMM5637
P 420	84/...	LMM64196	LMM64196		LMM3930	LMM7511		LMM5627	LMM7511					LMM3797	LMM5637
P 94	84/...	LMM64196	LMM64196		LMM3930	LMM7511		LMM5627	LMM7511					LMM3797	LMM5637
R 112	84/...	LMM64196 LMM7952	LMM64196 LMM7952		LMM5627	LMM7511		LMM5627	LMM7511	LMM7511		LMM7529	LMM7529	LMM3797	LMM7529
R 113	93/...	LMM64196	LMM64196	LMM64156	LMM5627	LMM7511		LMM5627	LMM7511	LMM7511		LMM7529	LMM7529	LMM3797	LMM7529
R 114	84/...	LMM64196	LMM64196		LMM3930	LMM7511		LMM5627	LMM7511					LMM3797	LMM5637
R 124	84/...	LMM64196	LMM64196		LMM3930	LMM7511		LMM5627	LMM7511					LMM3797	LMM5637
R 143	93/...	LMM64196	LMM64196	LMM64156	LMM5627	LMM7511		LMM5627	LMM7511	LMM7511		LMM7529	LMM7529	LMM3797	LMM7529
R 164	84/...	LMM64196	LMM64196		LMM3930	LMM7511		LMM5627	LMM7511					LMM3797	LMM5637
R 360	84/...	LMM64196	LMM64196		LMM3930	LMM7511		LMM5627	LMM7511					LMM3797	LMM5637
R 380	84/...	LMM64196	LMM64196		LMM3930	LMM7511		LMM5627	LMM7511					LMM3797	LMM5637
R 400	84/...	LMM64196	LMM64196		LMM3930	LMM7511		LMM5627	LMM7511					LMM3797	LMM5637
R 420	84/...	LMM64196	LMM64196		LMM3930	LMM7511		LMM5627	LMM7511					LMM3797	LMM5637
R 480	84/...	LMM64196	LMM64196		LMM3930	LMM7511		LMM5627	LMM7511					LMM3797	LMM5637
S 112	89/...	LMM64196	LMM64196	LMM64156	LMM5627	LMM7511		LMM5627	LMM7511	LMM7511		LMM7529	LMM7529		
T113	88-96	LMM64196	LMM64196 LMM64156	LMM64156	LMM5627	LMM7511	LMM5627	LMM5627	LMM7511	LMM7511	LMM7511	LMM7511	LMM5627		
T 114	84/...	LMM64196	LMM64196		LMM3930	LMM7511		LMM5627	LMM7511					LMM3797	LMM5637
T 114	96/...	LMM64196	LMM64196	LMM64155	LMM5627	LMM7511		LMM5627	LMM7511	LMM7511	LMM7511	LMM7511	LMM5627		
T 124	84/...	LMM64196	LMM64196		LMM3930	LMM7511		LMM5627	LMM7511					LMM3797	LMM5637
T 124	95/...	LMM64196	LMM64196	LMM64155	LMM5627	LMM7511		LMM5627	LMM7511	LMM7511	LMM7511	LMM7511	LMM5627		
T 143	88-96	LMM64196	LMM64196 LMM64156	LMM64156	LMM5627	LMM7511	LMM5627	LMM5627	LMM7511	LMM7511	LMM7511	LMM7511	LMM5627		
T 144	95/...	LMM64196	LMM64196	LMM64155	LMM5627	LMM7511		LMM5627	LMM7511	LMM7511	LMM7511	LMM7511	LMM5627		
T 360	84/...	LMM64196	LMM64196		LMM3930	LMM7511		LMM5627	LMM7511					LMM3797	LMM5637
T 400	84/...	LMM64196	LMM64196		LMM3930	LMM7511		LMM5627	LMM7511					LMM3797	LMM5637
T 420	84/...	LMM64196	LMM64196		LMM3930	LMM7511		LMM5627	LMM7511					LMM3797	LMM5637
T 93	88-96	LMM64196	LMM64196 LMM64156	LMM64156	LMM5627	LMM7511	LMM5627	LMM5627	LMM7511	LMM7511	LMM7511	LMM7511	LMM5627		
T 94	96/...	LMM64196	LMM64196	LMM64155	LMM5627	LMM7511		LMM5627	LMM7511	LMM7511	LMM7511	LMM7511	LMM5627		

VOLKSWAGEN

CAMINHÕES	83-86	LMM7951	LMM7951		LMM3893	LMM7506		LMM5008	LMM7506	LMM7506		LMM7506	LMM2721	LMM2821	LMM6461
CAMINHÕES	87-98	LMM7951	LMM7951		LMM3893	LMM7506		LMM7528	LMM7506	LMM7506		LMM7506	LMM2721	LMM2821	LMM6461
DELIVERY 5.140	.../06	LMM64193	LMM64193		LMM6411	LMM7506		LMM7528	LMM7506	LMM7506		LMM7506	LMM3893		LMM6411
DELIVERY 8.150	.../06	LMM64193	LMM64193		LMM6411	LMM7506		LMM7528	LMM7506	LMM7506		LMM7506	LMM3893		LMM6411
WORKER 8.120	.../06	LMM64193	LMM64193		LMM6411	LMM7506		LMM7528	LMM7506	LMM7506		LMM7506	LMM3893		LMM6411
WORKER 8.150E	.../06	LMM64193	LMM64193		LMM6411	LMM7506		LMM7528	LMM7506	LMM7506		LMM7506	LMM3893		LMM6411
WORKER 13.180	.../06	LMM64150	LMM64150		LMM6411	LMM7506		LMM7528	LMM7506	LMM7506		LMM7506	LMM3893		LMM6411
WORKER 15.180	.../06	LMM64150	LMM64150		LMM6411	LMM7506		LMM7528	LMM7506	LMM7506		LMM7506	LMM3893		LMM6411
WORKER 17.180	.../06	LMM64150	LMM64150		LMM6411	LMM7506		LMM7528	LMM7506	LMM7506		LMM7506	LMM3893		LMM6411
WORKER 13.170E	.../06	LMM64150	LMM64150		LMM6411	LMM7506		LMM7528	LMM7506	LMM7506		LMM7506	LMM3893		LMM6411



Linha de produtos Magneti Marelli

Lâmpadas automotivas



Modelo Ano Farol baixo Farol alto Nebl.diant. Lant.diant. Pisca dian. Pisca later. Lant. tras. Pisca tras. Luz freio Nebl. tras. Luz de ré Luz placa Luz painel Luz teto

VOLKSWAGEN (cont.)

WORKER 15.170E	.../06	LMM64150	LMM64150		LMM6411	LMM7506		LMM7528	LMM7506	LMM7506		LMM7506	LMM3893		LMM6411
WORKER 17.220 TRACTOR	.../06	LMM64150	LMM64150		LMM6411	LMM7506		LMM7528	LMM7506	LMM7506		LMM7506	LMM3893		LMM6411
WORKER 17.220	.../06	LMM64150	LMM64150		LMM6411	LMM7506		LMM7528	LMM7506	LMM7506		LMM7506	LMM3893		LMM6411
WORKER 24.220	.../06	LMM64150	LMM64150		LMM6411	LMM7506		LMM7528	LMM7506	LMM7506		LMM7506	LMM3893		LMM6411
WORKER 26.220	.../06	LMM64150	LMM64150		LMM6411	LMM7506		LMM7528	LMM7506	LMM7506		LMM7506	LMM3893		LMM6411
WORKER 17.250E	.../06	LMM64150	LMM64150		LMM6411	LMM7506		LMM7528	LMM7506	LMM7506		LMM7506	LMM3893		LMM6411
WORKER 24.250E	.../06	LMM64150	LMM64150		LMM6411	LMM7506		LMM7528	LMM7506	LMM7506		LMM7506	LMM3893		LMM6411
WORKER 26.260E	.../06	LMM64150	LMM64150		LMM6411	LMM7506		LMM7528	LMM7506	LMM7506		LMM7506	LMM3893		LMM6411
WORKER 31.260E	.../06	LMM64150	LMM64150		LMM6411	LMM7506		LMM7528	LMM7506	LMM7506		LMM7506	LMM3893		LMM6411
CONSTELLATION 13.180	.../06				LMM9507	LMM7511		LMM7537	LMM7511	LMM7511		LMM7511			LMM6429
CONSTELLATION 15.180	.../06				LMM9507	LMM7511		LMM7537	LMM7511	LMM7511		LMM7511			LMM6429
CONSTELLATION 17.250E	.../06	LMM64196	LMM64196		LMM9507	LMM7511		LMM7537	LMM7511	LMM7511		LMM7511			LMM6429
CONSTELLATION 24.250 6x2	.../06	LMM64196	LMM64196		LMM9507	LMM7511		LMM7537	LMM7511	LMM7511		LMM7511			LMM6429
CONSTELLATION TITAN TRACTOR 19.320	.../06	LMM64196	LMM64196		LMM9507	LMM7511		LMM7537	LMM7511	LMM7511		LMM7511			LMM6429
VOLKSBUS MINI / MICRO	.../06				LMM9507	LMM7511		LMM7537	LMM7511	LMM7511		LMM7511			LMM6429
VOLKSBUS RODOVIÁRIO	.../06				LMM9507	LMM7511		LMM7537	LMM7511	LMM7511		LMM7511			LMM6429
L 80	95-00	LMM64196	LMM64196		LMM3930	LMM7511		LMM5637	LMM7511	LMM7511		LMM7511	LMM5637		LMM5637

VOLVO

9700	01/...	LMM64156	LMM64156		LMM9507	LMM7511		LMM7511	LMM7511	LMM7511	LMM7537	LMM7511	LMM6423		
F 12	77-94	LMM64196	LMM64156		LMM9507	LMM7511	LMM5627	LMM7511	LMM7511	LMM7511	LMM7511	LMM7511	LMM5627		
FH 12	93/...	LMM64196	LMM64156	LMM64156	LMM9507	LMM7511	LMM5627	LMM7511	LMM7511	LMM7511	LMM7511	LMM7511	LMM5627		
FH 16	93/...	LMM64196	LMM64156	LMM64156	LMM9507	LMM7511	LMM5627	LMM7511	LMM7511	LMM7511	LMM7511	LMM7511	LMM5627		
FH 400	.../04	LMM64215	LMM64215	LMM64215	LMM9507	LMM7511	LMM5627	LMM7511	LMM7511	LMM7511	LMM7511	LMM7511	LMM5627		
FH 440	.../04	LMM64215	LMM64215	LMM64215	LMM9507	LMM7511	LMM5627	LMM7511	LMM7511	LMM7511	LMM7511	LMM7511	LMM5627		
FH 480	.../04	LMM64215	LMM64215	LMM64215	LMM9507	LMM7511	LMM5627	LMM7511	LMM7511	LMM7511	LMM7511	LMM7511	LMM5627		
FH 520	.../04	LMM64215	LMM64215	LMM64215	LMM9507	LMM7511	LMM5627	LMM7511	LMM7511	LMM7511	LMM7511	LMM7511	LMM5627		
FL 10	85-98	LMM64196	LMM64156		LMM9507	LMM7511	LMM5627	LMM7511	LMM7511	LMM7511	LMM7511	LMM7511	LMM5627		
FL 12	95-88	LMM64196	LMM64156		LMM9507	LMM7511	LMM5627	LMM7511	LMM7511		LMM7511	LMM7511	LMM5627		
FL 6	85-98	LMM64196	LMM64156		LMM9507	LMM7511	LMM5627	LMM7511	LMM7511	LMM7511	LMM7511	LMM7511	LMM5627		
FL 7	85-98	LMM64196	LMM64156		LMM9507	LMM7511	LMM5627	LMM7511	LMM7511	LMM7511	LMM7511	LMM7511	LMM5627		
FLC	96-00	LMM64155			LMM9507	LMM7511	LMM5627	LMM7511	LMM7511	LMM7537	LMM7511	LMM7511	LMM5627		
FM 10	.../02	LMM64196	LMM64156		LMM9507	LMM7511	LMM5627	LMM7511	LMM7511		LMM7511	LMM7511	LMM5627		
FM 12	.../04	LMM64215	LMM64215	LMM64215	LMM9507	LMM7511	LMM5627	LMM7511	LMM7511	LMM7511	LMM7511	LMM7511	LMM5627		
FM 400	.../04	LMM64215	LMM64215	LMM64215	LMM9507	LMM7511	LMM5627	LMM7511	LMM7511	LMM7511	LMM7511	LMM7511	LMM5627		
FM 440	.../04	LMM64215	LMM64215	LMM64215	LMM9507	LMM7511	LMM5627	LMM7511	LMM7511	LMM7511	LMM7511	LMM7511	LMM5627		
FM 480	.../04	LMM64215	LMM64215	LMM64215	LMM9507	LMM7511	LMM5627	LMM7511	LMM7511	LMM7511	LMM7511	LMM7511	LMM5627		
FM 7	98/...	LMM64196	LMM64156		LMM7537	LMM5627	LMM5627	LMM7511	LMM7511	LMM7511	LMM7511	LMM7511	LMM5627		
FS 7	91-96	LMM64196	LMM64196		LMM7511	LMM5627	LMM5627	LMM7511	LMM7511	LMM7511	LMM7511	LMM7511	LMM5627		
N 10	.../02	LMM64196	LMM64196		LMM5627	LMM7511	LMM5627	LMM7511	LMM7511	LMM7511		LMM7511	LMM5627		
N 12	.../02	LMM64196	LMM64196		LMM5627	LMM7511	LMM5627	LMM7511	LMM7511	LMM7511		LMM7511	LMM5627		
NH 12	.../02	LMM64196	LMM64196		LMM5627	LMM7511	LMM5627	LMM7511	LMM7511	LMM7511		LMM7511	LMM5627		
NL 10	.../02	LMM64196	LMM64196		LMM5627	LMM7511	LMM5627	LMM7511	LMM7511	LMM7511		LMM7511	LMM5627		
NL 12	.../02	LMM64196	LMM64196		LMM5627	LMM7511	LMM5627	LMM7511	LMM7511	LMM7511		LMM7511	LMM5627		
VM 17	.../02	LMM64196	LMM64196		LMM5627	LMM7511	LMM5627	LMM7511	LMM7511	LMM7511		LMM7511	LMM5627		
VM 23	.../02	LMM64196	LMM64196		LMM5627	LMM7511	LMM5627	LMM7511	LMM7511	LMM7511		LMM7511	LMM5627		
VM 210	.../02	LMM64196	LMM64196		LMM5627	LMM7511	LMM5627	LMM7511	LMM7511	LMM7511		LMM7511	LMM5627		
VM 260	.../02	LMM64196	LMM64196		LMM5627	LMM7511	LMM5627	LMM7511	LMM7511	LMM7511		LMM7511	LMM5627		
VM 310	.../02	LMM64196	LMM64196		LMM5627	LMM7511	LMM5627	LMM7511	LMM7511	LMM7511		LMM7511	LMM5627		
VM 310R	.../02	LMM64196	LMM64196		LMM5627	LMM7511	LMM5627	LMM7511	LMM7511	LMM7511		LMM7511	LMM5627		



Índices de Bases



SV7-8

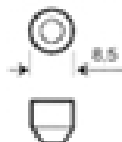

SV8.5-8

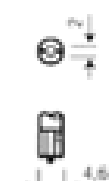

W2x4.6d

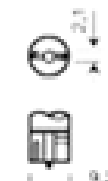

W3x16d

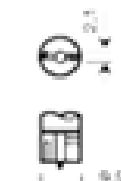

W2.1x9.5d

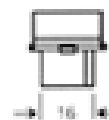

W2.5x16d



W2.5x16q



BA15s



BAU15s



BAU15d



BAY15d



BAZ15d



BA9s



BAY9s



B8,4-12,5



B8,5d



B8,3d



P14.5s



PK22s



P29t



PX29t

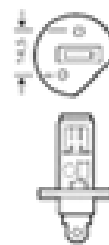

PX14,5s



PX26d



P43t



P45t



PGJ19
PGJ19-1
PGJ19-2
PGJ19-5



P20d



P22d

linha de
produtos

MAGNET
MARE

máquina rotante
regulador de voltagem



DESIGNAÇÕES DE TERMINAIS/ Terminal Designations

SISTEMA ELÉTRICO/ Electrical System	POSITIVO DA BATERIA/ Battery Positive	NEGATIVO DA BATERIA/ Battery Negative	CAMPO/ Field	SENSOR DE BATERIA/ Battery Sense	ATERRAMENTO/ Ground	TRIO DIODO/ Diode Trio	LÂMPADA INDICADORA/ Indicator Light	TERMINAL RESISTOR/ Resistor Terminal
BOSCH	B+	B-	DF	-	D-	D+	L	-
BOSCH/ WAPSA	B+	B-	DF	-	D-	D+	L	-
DELCO	B+	B-	DF	S	D-	D+	L	-
FORD	B+	B-	DF	-	D-	-	L OU/OR I	-
HITACHI	B+ OU/OR B+	E OU/OR B-	F OU/OR DF	S	E OU/OR D-	D+	L	R
ISKRA	B+	B-	DF	-	D-	D+	L	-
LUCAS	B+	B-	DF	-	D-	D+	L	-
MAGNETI MARELLI	B+	B-	DF	S	D-	D+	L	-
MITSUBISHI	B+	B-	DF	S	D-	D+ TRIO	L	R
NIPPON DENSO	B+	B-	DF	S	D-	-	L	-
POONG SUNG	B+	B-	DF	-	D-	D+	L	-
VALEO	B+	B-	DF	-	D-	D+	L	-

SISTEMA ELÉTRICO/ Electrical System	IGNIÇÃO/ Ignition	AUXILIAR/ Auxiliary	CAMPO/ Field	SAÍDA DE FASE DO ESTRATOR/ Stator Output	NEUTRO/ Neutral	MONITORAMENTO DO CAMPO/ Field Report	COMUNICAÇÃO COM A CENTRAL Computer Input	TERMINAL NÃO CONECTADO/ Disconnected Terminal
BOSCH	IG	AUX	W	-	N	DFM	-	-
BOSCH/ WAPSA	IG	AUX	W	-	N	DFM	-	-
DELCO	IG OU/OR I	-	W	P	N	F	-	-
FORD	B+	-	S OU/OR W	-	-	FR	SIG	-
HITACHI	IG	-	W	-	-	-	-	-
ISKRA	-	-	-	-	-	-	-	-
LUCAS	-	AUX	W	-	-	-	-	-
MAGNETI MARELLI	IG	-	W	P	-	FR	C	-
MITSUBISHI	-	-	W	P	-	FR	C	D
NIPPON DENSO	IG	-	W	P	-	FR	C	D
POONG SUNG	-	-	-	-	-	-	-	-
VALEO	IG	-	W	-	N	-	-	-



Linha de produtos Magneti Marelli Regulador de voltagem



RT510067



Especificações/ Features:	28V / 65A Campo negativo / 'B' circuit, 3 Terminais / 3 Terminals
Substitui/ Replaces:	Bosch: 0.192.033.001, 0.192.033.002, 0.192.033.004
Aplicação/ Application:	SCANIA: Mot. Marítimos Dn11, Ds11, Ds14, Plat. p/ ônibus K, S 112, CATERPILLAR: Motoniveladoras, Tratores D4E, D6D, MAXION: Tratores MF 265E, 265-4 Alternador / Alternator: BOSCH: 9.120.080.062, 9.120.080.071, 9.120.080.074, 9.120.080.082

RT510068



Especificações/ Features:	28V / 55A Campo negativo / 'B' circuit, 4 Terminais / 4 Terminals
Substitui/ Replaces:	Bosch: 0.192.033.003, 0.192.033.005
Aplicação/ Application:	SCANIA: Caminhões L, LS, LT 110, 110S, 111, 111S, LS, LKS 140, 141, 142, T112, R112, Chassi p/ ônibus BR 116S, Mot. Marítimos, Ind. e geradores Dn11, Ds11, Ds14., VOLVO: Caminhão N 10, N12, Plataforma p/ ônibus B58E., CUMMINS: Motores N, NT, NTA, NTTA 855. Alternador / Alternator: BOSCH: 9.120.080.088, 9.120.080.109, 9.120.080.110, 9.120.080.124, 9.120.080.125

RT510069

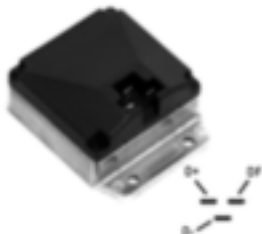

Especificações/ Features:	14V / 55A Campo negativo / 'B' Circuit, 3 Terminais / 3 Terminals
Substitui/ Replaces:	
Aplicação/ Application:	CATERPILLAR: Máquinas e Equipamentos com Alternador Bosch 14V.

RT510074



Especificações/ Features:	28V / 45A Campo Negativo / 'B' circuit
Substitui/ Replaces:	Bosch: 9.190.085.000
Aplicação/ Application:	MB: Caminhões 1924 (OM 355-6), 1924A, 2624A (OM 355-6 A) até 04.82). Caminhões 1929 (OM 355-6 A), 1932 (OM 355-6 LA) até 05.85). Plat. e ônibus O 370 R, RS, RSD (OM 355-5,6,6 A, 6 LA) até 05.85). FIAT: Caminhões Fiat 70/80/100/130/140/180/190, FNM 210. KOMATSU: Trat. D60A/E/F, D65A/E. FIAT ALLIS: Trator Ad78, CATERPILLAR: Motoniv. 3306, Pás Carreg. 930 e 966, Trat. de Esteira D4E e D6E. Todos (até 12.80). Alternador / Alternator: BOSCH: 9.120.080.039/049/055/058/064/067/069/073/075/085/086/094/103/104/105/106/113/146/150/189.

RT510075



Especificações/ Features:	28V / 45A Campo negativo / 'B' circuit
Substitui/ Replaces:	Bosch: 9.190.085.000
Aplicação/ Application:	MB: Caminhões / Trucks 1924 (OM 355-6), 1924A, 2624A (OM 355-6 A) até 04.82; Caminhões / Trucks 1929 (OM 355-6 A), 1932 (OM 355-6 LA) até 05.85; Plat. e ônibus / buses O 370 R, RS, RSD (OM 355-5,6,6 A, 6 LA) até 05.85, CATERPILLAR.: Motoniv. 3306, Pás Carreg. 930 e 966, Tratores de Esteira D4E e D6E, todos até 12.80, KOMATSU: Tratores D60A/E/F, D65A/E. FIAT ALLIS: Trator Ad78. FIAT: Caminhões / Trucks Fiat 70/80/100/130/140/180/190, FNM 210. Alternador / Alternator: BOSCH: 9.120.080.039/ 049/ 055/ 058/ 064/ 067/ 069/ 073/ 075/ 085/ 086/ 094/ 103/ 104/ 105/ 106/ 113/ 146/ 150/189.

RT510077

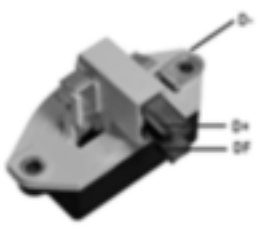

Especificações/ Features:	28V / 55A Campo positivo / 'A' circuit
Substitui/ Replaces:	Bosch: 9.190.087.018, 9.190.087.014, 0.192.053.006.
Aplicação/ Application:	MB: Caminhões / Trucks, Ônibus / Buses, Estac. e Marít. com alt. 28V, VOLVO: Caminhões / Trucks N10 (TD101 F/G), N12 (TD121 F/G), NL 12-400, NL 10-280, NL10-340, N10 (TD100G), N12 (TD121GA) após 03.84, Ônibus / Buses B10M, B58E após 03.84. CATERPILLAR: Motoniv. 3306, Pás 930 e 966, Trat. D4, D5, D6, D4E, D6D, D8L, 631E, 930 E 966. SCANIA: Caminhões / Trucks T112, R112, T142, R142, T/R 112/310, T/R 112-360HW, T/R 142-410 HW, Mot. Marí., FORD: Caminhões / Trucks Cargo. Alternador / Alternator: BOSCH: 0.120.469.527/ 691/ 752/ 753, 0.120.488.125/ 232, 0.120.489.053/ 060/ 071/ 221/ 230/ 231/ 284/ 684/ 727, F010 LDO-102, 9.120.080.114/ 126/ 128/ 137/ 144/ 147/ 151/ 174/ 181/ 187/ 207/ 219.



Linha de produtos Magneti Marelli Regulador de voltagem



RT510085

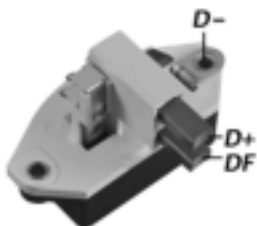

Especificações/ Features:	14V / 55A Campo positivo / 'A' circuit
Substitui/ Replaces:	Bosch: 9.190.087.034, 9.190.087.023, 9.190.087.016, 9.190.087.031
Aplicação/ Application:	MB: Caminhões / Trucks, Ônibus / Buses, Estac. Ind. e Marít. com alternador / alternator 14V. CBT: Tratores / Tractors 8240, 2105, 8060. MAX ION: Colheit. MF1630/ 3640/ 5650. Retr. M750, MF86. Tratores / Tractors 9110/ 9130. Estac. 4 e 6 Cil. Ind. MF235/ 265/ 272/ 275/ 283/ 290/ 292. TOYOTA: Bandeirante (após 88). AGRALE: Caminhões / Trucks 1800K. Estac. M80/85/90. Tratores / Tractors 4200/4300 (M790) (após / after 06.85). Alternador / Alternator: BOSCH: 0.120.468.028/055, 9.120.080.112/ 113/ 130/ 136/ 140/ 141/ 142/ 143/ 145/ 148/ 149/ 154/ 157/ 158/ 159/ 160/ 161/ 162/ 163/ 164/ 166/ 167/ 175/ 176/ 177/ 178/ 179/ 182, 9.120.080.183/ 184/ 185/ 186/ 188/ 190/ 191/ 192/ 193/ 194/ 195/ 196/ 197/ 199/ 200/ 201/ 202/ 204/ 214/ 218 / 182

RT510088



Especificações/ Features:	28V / 140A Campo positivo / 'A' circuit
Substitui/ Replaces:	Bosch: 9.190.457.001, 1.197.311.315, 9.190.457.051, 1.197.311.316, 0.192.053.003, 0.192.053.012, 0.192.053.025, 0.192.053.009, 0.192.053.014
Aplicação/ Application:	FORD / VW: Chassis p/ ônibus Volksbus. c/ alt. 9.120.456.039 (75A), MAFERSA: Ônibus / Buses M-210, M-240, c/ alt. 9.120.456.042 (75A), MB: Chassis e Ônibus / Buses O370 RS, O370 RSD, O371 R, O371 RS, O371 RSD, O371 U, O371 UP, OF/OH, BR 400, Motor M366 G, O400 UP, todos c/ alt. / all with alternator 9.120.456.001. VOLVO: Ônibus / Buses B58, B10 M, c/ Alt. 9.120.456.011, RANDOM: Caminhão fora de estrada / out of road trucks Alternador / Alternator: BOSCH: 0.120.689.535/ 562, 9.120.456.001/ 010/ 011/ 012/ 015/ 031/ 032/ 034/ 036/ 038/ 039/ 040/ 041/ 042/ 043/ 046/ 047/ 048/ 049/ 050/ 052/ 053, 9.120.080.015/ 038.

RT510089



Especificações/ Features:	28V / 105A Campo positivo / 'A' circuit
Substitui/ Replaces:	Bosch: 9.190.457.003, 9.190.457.048, 9.192.053.021, 1.197.311.320
Aplicação/ Application:	SCANIA: Ônibus / Buses, Chassis p/ Ônibus F112 HL, F113 HL, K113 CL, L113 CL, S113 AL, S113 CL, todos com alternador / all with alternator 9.120.456.003 (105A). Ônibus / buses com alt. 9.120.456.014 (105A), MAFERSA: Trolebus com alternador / alternator 9.120.456.028 (75A). Alternador / Alternator: BOSCH: 9.120.456.003 / 014 / 028 / 033.

RT510090



Especificações/ Features:	14V / 90A Campo positivo / 'A' circuit
Substitui/ Replaces:	Bosch: 9.190.457.043
Aplicação/ Application:	MAXION: Colheitadeira 3640, 5650 com motor PER 6.354.4 e alt. 9.120.456.027 (90A), VW: Caminhões / Trucks 22.210, 23.210 com motor Cummins (eq. primário) e alternadores / alternators 9.120.456.030 (90A), MB: Ônibus Urbano diverso / Various urban buse, RENAULT: R19, R21. Alternador / Alternator: BOSCH: 9.120.456.008/ 026/ 027/ 030/ 037, 9.120.080.048/ 052/ 215.

RT510139



Especificações/ Features:	28V / 65A Campo positivo / 'A' circuit
Substitui/ Replaces:	Bosch: 1.197.311.301, 1.197.311.300, 1.197.311.305, 1.197.311.306
Aplicação/ Application:	MERCEDES-BENZ: Caminhões / Trucks 609, 611, 614, 709, 711, 714, 809, 811, 814, 914, 917, 1114, 1320, 1514; Chassis e Ônibus / Buses OF1315, OF1318, OH1418 e 1635. Alternador / Alternator: BOSCH: 0.120.468.131 / 053 / 054 / 107 / 113 / 136 / 137, 0.120.469.001 / 008 / 019 / 025 / 032 / 039 / 115 / 116 / 518 / 562 / 652 / 692 / 761 / 772 / 797 / 807 / 856 / 857.

RT510140



Especificações/ Features:	28V / 80A Campo positivo / 'A' circuit
Substitui/ Replaces:	Bosch: 1.197.311.304
Aplicação/ Application:	IVECO: Caminhões / Trucks série 180E, 190E, 240E, 260E, 400E (até 09.92), SCANIA: Caminhões / Trucks MT-DS11.94, 95, 96, 97, DS14.52, DSC11.56, 57, 58, 14.57, 61, 62, 63 e outros. VOLVO: Caminhões / Trucks F12 e N12 (até 01.90) B12, NL10, 12, Chassi B12 (até 01.96). Alternador / Alternator: BOSCH: 0.120.468.094/ 114/ 131, 0.120.469.014/ 026/ 643/ 999, 0.120.488.271/ 303/ 410.



Linha de produtos Magneti Marelli Regulador de voltagem



RT510142

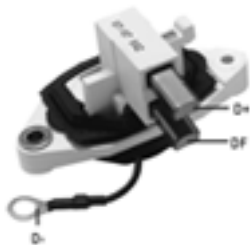

<i>Especificações/ Features:</i>	28V Campo positivo / 'A' circuit
<i>Substitui/ Replaces:</i>	Bosch: 0192035020; 0192053015; 0192053020; 1197311308; 1197311312; 1197311327; 2197311308; 2197311312, Cargo: 136545
<i>Aplicação/ Application:</i>	RENAULT: Ares 300, 340; Agora Line; Kerax; M210 Midliner; M250 Midliner; Premium 210 – 400; VOLVO e SCANIA: Caminhões / Trucks Alternador / Alternator: BOSCH: 0120468132, 0120469024, 0120469036, 0120469037, 0120469693, 0120469952, 0120469963, 0120469983

RT510116

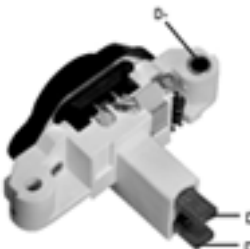

<i>Especificações/ Features:</i>	14V / 100A, Campo positivo / 'A' circuit, Com resistor / With resistor
<i>Substitui/ Replaces:</i>	Bosch: 1.197.311.211, 1.197.311.213, 1.197.311.217, 1.197.311.219
<i>Aplicação/ Application:</i>	MERCEDES, VOLVO, VW: Corrado, Passat. Alternador / Alternator: BOSCH: 0.120.485.011/ 012/022, 0.120.465.004/ 015/ 017, 0.123.315.005, 0.123.320.041, 0.123.335.002/ 003, 0.123.510.101, 0.123.520.012, 0.123.540.004.

RT510145

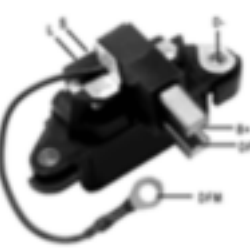

<i>Especificações/ Features:</i>	14V Campo Positivo / 'A' Circuit.
<i>Substitui/ Replaces:</i>	Bosch: 9190067018, Cargo: 36555
<i>Aplicação/ Application:</i>	Alternador / Alternator: BOSCH: 0120060027, 9120060023, 9120060027, PIC: 220344, 220344A, 220344C

RT510122

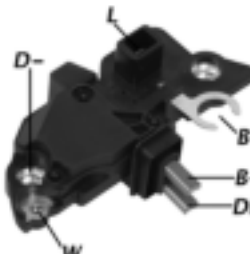

<i>Especificações/ Features:</i>	14V Campo positivo / 'A' circuit
<i>Substitui/ Replaces:</i>	Bosch: F 00M 145 229
<i>Aplicação/ Application:</i>	VOLVO: S80 1999-2000 2.8L 120A, S80 1999-2001 2.9L 120A, S60 2001 2.3L, 2.4L 120A, Cross Country 2001 2.4L 120A Alternador / Alternator: BOSCH: 0124515017; 0124515054; 0124525001; 0124525014

RT510123

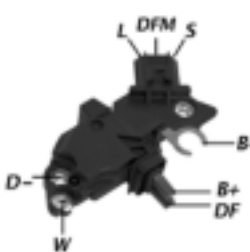

<i>Especificações/ Features:</i>	14V Campo positivo / 'A' circuit
<i>Substitui/ Replaces:</i>	Bosch: F 00M 145 214; F 00M 145 348
<i>Aplicação/ Application:</i>	CUMMINS: F250, F350, F4000, MWM Alternador / Alternator: BOSCH: 0124315019; 0124415006

RT510071



<i>Especificações/ Features:</i>	14V / 90A, Campo Negativo / 'B' circuit, Proteção contra curto / Short protection
<i>Substitui/ Replaces:</i>	Bosch: 9.190.457.008, Wapsa: RWA-, T-22
<i>Aplicação/ Application:</i>	FORD: Caminhão / Truck Cargo 1218 / 1415 / 1418 / 1519 / 1521 / 1618 / 1621 / 2218 / 2319 / 2321 / 3021 / 3223 c/ motor FORD 6.6 / 7.8 litros. Alternador / Alternator: BOSCH: 9.120.456.004/ 005/ 013/ 024/ 025 .



RT510125

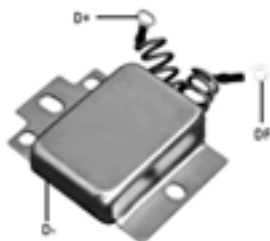

<i>Especificações/ Features:</i>	28V / 35A, Campo negativo / 'B' circuit
<i>Substitui/ Replaces:</i>	Delco: 1117236, Caterpillar: 2P1699, 952329, 6N3821
<i>Aplicação/ Application:</i>	Caterpillar: Tratores, Carregadeiras, Motoniveladora. Alternador / Alternator: 2P1204.

RT510238



<i>Especificações/ Features:</i>	14V, Campo Positivo / 'A' circuit, Terminais RSBFE
<i>Substitui/ Replaces:</i>	Hitachi: TR1Z-46, Isuzu: 8 9422 3 9670
<i>Aplicação/ Application:</i>	ISUZU: Diesel Alternador / Alternator: HITACHI: LR140112; ISUZU:8-94221-4514

RT510239



<i>Especificações/ Features:</i>	14V, Campo Positivo / 'A' circuit, Terminais RRLDFE
<i>Substitui/ Replaces:</i>	Hitachi: L13513152; TR1Z-44; TR1Z-49; TR1Z-63
<i>Aplicação/ Application:</i>	Industrial Maruine Alternador / Alternator: HITACHI: LR120-15, LR120-15C, LR120-23, LR125-34, LR135-105, LR135-116, LR135-126, LR135-127, LR-135-58, LR135-58B, LR135-86, LR135-86C, LC135-86F, LR135-91, LR135-95, LR135-95B, LR150-165, LR155-20, LR155-20B, LR155-29, LR165-01, LR165-01C, LR165-03, ISUZU: 1705877200, 5001810100, 5812003381, 5812003410, 5812003411, 5812003470, 5812003580, 8944179240, 8944237560, NISSAN: 23100-95004, 23100-95009, 23100-95013

RT510240



<i>Especificações/ Features:</i>	28V, Campo Positivo / 'A' circuit, Terminais RRLFE
<i>Substitui/ Replaces:</i>	Hitachi: tr2z-47, Nissan: 23500-99008, Isuzu: 5 8125 1 0160, Cargo: 135026
<i>Aplicação/ Application:</i>	Isuzu: Industrial, Nissan Alternador / Alternator: HITACHI: LR21523; LR21524; LR21550; LR22023; LR22024; LR22584T; LR22585; LR22586B; LR22589; LR23560C; LR23561C; LR23562; LR23565; LR23568; LR23569; LR23572B; LR23576; LR23580; LR24019C; LR24020C; LR24021; LR24022E; LR24025; LR24026; LR24029B; LR24031E; LR24032

RT510148

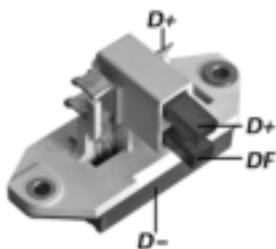

<i>Especificações/ Features:</i>	14V, Campo positivo / 'A' circuit
<i>Substitui/ Replaces:</i>	Iskra: 11 125 019, 11 125 053, 11 125 054, 11 125 056, 11 125 065, 11 125 085, 16 905 323, AER 1401, AER 1406, AER 1505, AER 1506, AER 1510, Zastava: 1301670.
<i>Aplicação/ Application:</i>	YUGO Alternador / Alternator: ISKRA: 11201273, AAK1314, LESTER: 13225, PIC: 220188, 282100.

RT510149

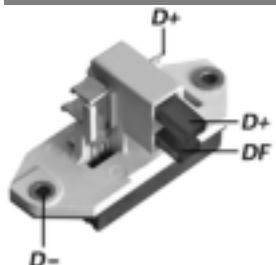

<i>Especificações/ Features:</i>	28V, Campo positivo / 'A' circuit
<i>Substitui/ Replaces:</i>	Iskra: 11125029; 11125047; 11125087; 16905304; AER1404; AER1504; AER1511
<i>Aplicação/ Application:</i>	KHD: Tratores / Tractors Alternador / Alternator: ISKRA: 11201050; 11201052; 11201066; 11201069; 11201087; 11201098; 11201107; 11201151; 11201162; 11201186; 11201201; 11201360; 11201522; 11201555; 11201557; 11201574; 11201586; 11201633; 11201635; 11201699; 1120170; 3120105; AAK1107; AAK1109; AAK1110; AAK1113; AAK1115; AAK1125; AAK1131; AAK1134; AAK1153; AAK1160; AAK1167; AAK1309; AAK1347; AAK1352; AAK1367; AAK3520; AAK3557; AAK4179; AAK4507; AAK4509; AAK4531; AAK4560



Linha de produtos Magneti Marelli Regulador de voltagem



RT510105



Especificações/ Features:	14V / 75A, Campo positivo / 'A' circuit
Substitui/ Replaces:	Lucas: UCB148, UCB150, UCB151, 37701, 37703, 37705, 37707, 54205986, 54206177, 5420448, 5420467, 5420645.
Aplicação/ Application:	FORD: Fiesta. MF: Tratores / Tractors, J. I. CASE Alternador / Alternator: LUCAS: 24145/ 156/ 157/ 158/ 161/ 169/ 198/ 199/ 200/ 206/ 207/ 208/ 223/127 .

RT510173

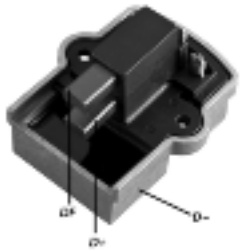

Especificações/ Features:	14V / 55A, Campo positivo / 'A' circuit
Substitui/ Replaces:	Lucas: 353.81.695.
Aplicação/ Application:	FORD: F100 e F4000; Veículos Argentinos diversos. Alternador / Alternator: LUCAS: 352.13.295/ 740/ 800/ 855/ 352, 352.14.090.

RT510169



Especificações/ Features:	28V / 90A, Campo positivo / 'A' circuit
Substitui/ Replaces:	Lucas: 353.81.640
Aplicação/ Application:	EL DETALLE: Ônibus / Trucks, MB: Ônibus e Caminhões / Buses and Trucks, SCANIA: Ônibus e Caminhões / Buses and Trucks, Máquinas Agrícolas / Agricultural machines Alternador / Alternator: LUCAS: MO 240 90R, MB 240 55R, MB 240 90R, 5C 240 55R, 5C 240 90R, 9120 456 003, B 0120 46 9001, B 9120 45 6034, O 120 46 9920.

RT510170



Especificações/ Features:	14V / 100A, Campo positivo / 'A' circuit
Substitui/ Replaces:	Lucas: 353.81.645
Aplicação/ Application:	MB: Ônibus e Caminhões / Buses and Trucks, SCANIA: Ônibus, Caminhões e Máquinas Agrícolas / Buses, Trucks and Agricultural Machines, SEVEL: Motores Peugeot, ZANELLO: Vários. Alternador / Alternator: LUCAS: 121 00R, 5C 121 00R, 9120 456 003.

RT510187

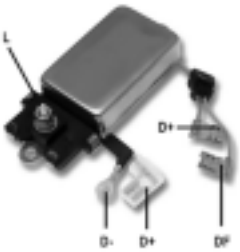

Especificações/ Features:	14V / 100A, Campo positivo / 'A' circuit
Substitui/ Replaces:	Lucas: 353.81.725
Aplicação/ Application:	DEUTZ: Ônibus, FORD: Fiesta, Fiesta 1.4 c/ar ou s/ar cond., MB: Ônibus e Caminhões. Alternador / Alternator: LUCAS: 352.13.690, 352.14.305, 372.15.07250.

RT510188

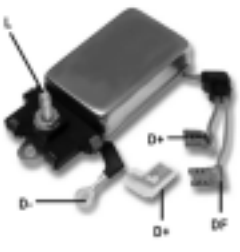

Especificações/ Features:	14V / 70A, Campo positivo / 'A' circuit
Substitui/ Replaces:	Lucas: 353.81.760
Aplicação/ Application:	BORGWARD: Motores, FORD: Caminhões, MB: Ônibus . Alternador / Alternator: LUCAS: 352.14.390, 352.14.375, 352.14.560.



Linha de produtos Magneti Marelli Regulador de voltagem



RT510095

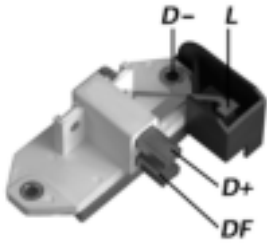

Especificações/ Features:	28V, Campo positivo / 'A' circuit
Substitui/ Replaces:	Magneti Marelli: 797 074 41, RTT 119 B, Fiat: 8 190 407, Lucas: 21222126, UCB 806, VL-Ducellier: 592 968.
Aplicação/ Application:	FIAT: Tratores / Tractors Alternador / Alternator: M. MARELLI: 633 200 25, 633 200 52, 633 200 57, 633 201 18, 633 210 46, 633 210 47, 633 210 48, 633 210 49, 633 210 50, 633 210 52, 633 210 55, 633 210 63, 633 211 02, 633 211 04, 633 211 10. PIC: 20211.

RT510101

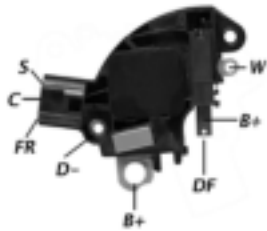

Especificações/ Features:	14V Campo Positivo / 'A' Circuit.
Substitui/ Replaces:	Magneti Marelli: 085582601010
Aplicação/ Application:	CUMMINS; VW; FORD: Focus 1.8, 2.0 00-05 Alternador / Alternator: MAGNETI MARELLI: 63321677; 63321678; 63321679; 63321746; 63341677; 63341679; 63341746; FORD: 98AB10300DI

RT510190



Especificações/ Features:	28V, Campo Positivo, 'A' circuit
Substitui/ Replaces:	Mitsubishi: A866T06870, ME700635
Aplicação/ Application:	MITSUBISHI: Canter FE431; Canter FE444; Caminhões / Trucks, Mitsubishi Fuso no Estado Unidos / in the U.S.A. Alternador / Alternator: MITSUBISHI: 34468-25100, A2T72483, A2T72986, A2T72987, A2T72999, A2T73387, ME049175, ME049177, ME070120, ME087508

RT510192

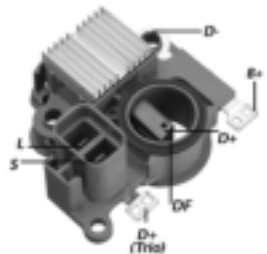

Especificações/ Features:	14V, Campo Positivo / 'A' Circuit, Terminais: S-L.
Substitui/ Replaces:	Mitsubishi: A2T34892/ 35092/ 38892/ 40092/ A2871, A3T12291 / 12391 / 12491, A 866 X 22272, A 866 X 23182, A 866 X 25472, MD618569, MD618696.
Aplicação/ Application:	FORD, MITSUBISHI, NISSAN; HYSTER: Empilhadeiras XM, GLP, GTP, GP Alternador / Alternator: MITSUBISHI: A002T34892, A002T34991, A002T34992, A002T35091, A002T36391, A002T36392, A002T38291, A002T38391, A002T38491, A002T38891, A002T38892, A002T39991, A002T39992, A002T40092, A002T80591, A002TA0991, A002TA3491, A003T11591, A003T12991, A003T13091, A003T13191, A003T13291, A003T14491, A003TA0791, A003TA1191, A003TA1391, A005T05091, A005T07592, A2T34892, A2T34991, A2T34992, A2T35091, A2T35092, A2T36391, A2T36392, A2T38291, A2T38391, A2T38491, A2T38891, A2T38892, A2T39992, A2T40092, A2T80591, A2T80591ZC, A2T81791, A2TA2871, A3T11591, A3T12291, A3T12491, A3T12991, A3T13091.

RT510230



Especificações/ Features:	14V Campo Positivo / 'A' Circuit; 63.5 mm Mounting; Terminais: P-IG-L, Terminal 'L' sem / without drive choke
Substitui/ Replaces:	Nippondenso: 126000-1940
Aplicação/ Application:	CATERPILLAR, YANMAR . Alternador / Alternator: NIPPONDENSO: 1012119010, 1012119940.

RT510209

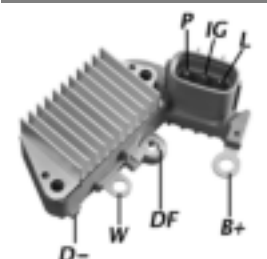

Especificações/ Features:	14V , Campo positivo / 'A' Circuit, Terminais:P-IG-L, Mount. 57.5 mm, Terminal 'L' sem / without drive choke
Substitui/ Replaces:	Nippondenso: 126000-1800
Aplicação/ Application:	CATERPILLAR: Máquinas e Equipamentos / machines and equipments ACURA: Integra HONDA: Civic. Alternador / Alternator: NIPPONDENSO: 101211-2310, 105-2812, CATERPILLAR: 333-224.



Linha de produtos Magneti Marelli Regulador de voltagem



RT510206



Especificações/ Features:	14V Campo Positivo / 'A' Circuit ; Mount: 57.5 mm ; Terminais: S-IG-L, Terminal 'L' com / with drive choke
Substitui/ Replaces:	Nippondenso: 126000-7040.
Aplicação/ Application:	TOYOTA: Empilhadeiras / Forklifts Alternador / Alternator: NIPPONDENSO: 1002114540, 1002116931, 1002116930, 1002116960, PIC: 290185, 290206, 290207, 290227, TOYOTA: 2706078003, 2706078305, 2707023041, LESTER: 12183, 12184, 12187.

RT510234



Especificações/ Features:	14V Campo Positivo / 'A' Circuit; 57.5 mm Mounting; Terminais: IG-L, Terminal 'L' sem / without drive choke
Substitui/ Replaces:	Nippondenso: 126000-0600/ 0760/ 1160.
Aplicação/ Application:	Empilhadeiras e outras aplicações industriais. Alternador / Alternator: NIPPONDENSO: 1002111511 / 540 / 550 / 580 / 590 / 610 / 630 / 650 / 680 / 690, 1002114050 / 060 / 080 / 091 / 180 / 200 / 200 / 220 / 230 / 240 / 250 / 360 / 382, 1002111670, 1002114460 / 482 / 520 / 550 / 560 / 700, 1002116221, 1002111662, 1002116640 / 760 / 770 / 880 / 890 / 900 / 920, PIC: 290208.

RT510247

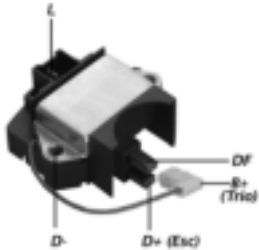

Especificações/ Features:	28V Campo Positivo / 'A' circuit
Substitui/ Replaces:	Valeo: 92955, NC 692, ZL 127.
Aplicação/ Application:	Industrial. Alternador / Alternator: VALEO: 2099801 / 821, 2103484 / 0225 / 3164 / 3163, A12R351T / 35T, A14R134 / 54 / 543 / 134T / 541T / 543T / 341T / 542T / 545T / 35T / 34T / 54T.

RT510242

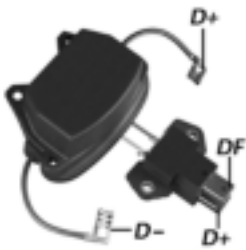

Especificações/ Features:	14V, Campo positivo / 'A' circuit
Substitui/ Replaces:	Valeo: 2590512, 300741, 300692, 92966, NC927, NC362, VI. Paris Rhone: YL135, YL146, IL 147, Lucas: UCB243
Aplicação/ Application:	RENAULT: Marine, VOLVO: Penta. Alternador / Alternator: VALEO: A13N28M, A14N48M, A14N66M, A13N29M, A13N35M, A13N55M, A13N57M, A13N58M, A13N66M, A14N29M, A13N148M, A13N186M, A13N259M, A13N35M, A13N36M.

RT510243

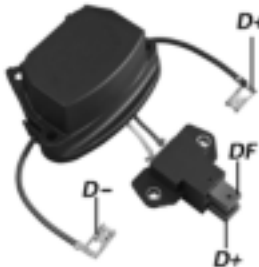

Especificações/ Features:	28V, Campo positivo / 'A' circuit
Substitui/ Replaces:	Valeo: 300744, NC184, P. Rhone: ZL129, Lucas: 21225372, UCB 239, M. Marelli: 940 038 174.
Aplicação/ Application:	VOLVO: Penta, Aplicações Industriais. Alternador / Alternator: VALEO: A13N143M, A13N152M, A13N36M, A13N56M, A13N59M, A14N110M, A14N112M, A14N115M, A14N116M, A14N118M, A14N206M, A14N47M.

RT510244

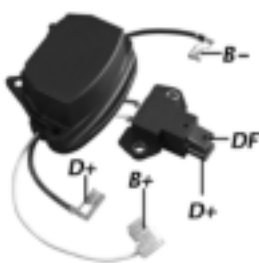

Especificações/ Features:	28V, Campo positivo / 'A' circuit
Substitui/ Replaces:	Valeo: 590536, P. Rhone: ZV 3729; ZY 3729, Volvo: 872368, Magneti Marelli: 940 038 173
Aplicação/ Application:	VOLVO: Caminhões / Trucks F10; F12; FL10; FL6; FL7; N10; N12 Alternador / Alternator: VALEO: 2102052, 2180619, 2180620, 2181991, 2541168, 2541199, A13N33M, A14N100M, A14N119M, A14N122M, A14N137, A14N137M, A14N141M, A14N200, A14N200M, A14N30M, A14N81M, PIC: 208399, 208400



Linha de produtos Magneti Marelli
Regulador de voltagem



RT510245

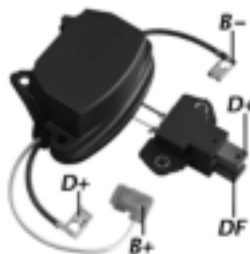

Especificações/ Features:	14V, Campo positivo / 'A' circuit
Substitui/ Replaces:	Valeo: 2518337; 2541291; 2590512; 300692; 300741; 300747; 92966; YV7735; YV7735H
Aplicação/ Application:	VOLVO: Marine Alternador / Alternator: VALEO: 2100605; 2100606; 2102051; 2102341; 2102794; 2103141; 2103142; 2105582; 2518088; A13N147M; A13N148M; A13N149M; A13N1M; A13N35M; A13N55M; A13N66M; A14N148; A14N29M



DESIGNAÇÕES DE TERMINAIS/ Terminal Designations

SISTEMA ELÉTRICO/ Electrical System	POSITIVO DA BATERIA/ Battery Positive	NEGATIVO DA BATERIA/ Battery Negative	CAMPO/ Field	SENSOR DE BATERIA/ Battery Sense	ATERRAMENTO/ Ground	TRIO DIODO/ Diode Trio	LÂMPADA INDICADORA/ Indicator Light	TERMINAL RESISTOR/ Resistor Terminal
BOSCH	B+	B-	DF	-	D-	D+	L	-
BOSCH/ WAPSA	B+	B-	DF	-	D-	D+	L	-
DELCO	B+	B-	DF	S	D-	D+	L	-
FORD	B+B	-	DF	-	D-	-	L OU/OR I	-
HITACHI	B+ OU/OR B+	E OU/OR B-	F OU/OR DF	S	E OU/OR D-	D+	L	R
ISKRA	B+	B-	DF	-	D-	D+	L	-
LUCAS	B+	B-	DF	-	D-	D+	L	-
MAGNETI MARELLI	B+	B-	DF	-	D-	D+	L	-
MITSUBISHI	B+	B-	DF	S	D-	D+ TRIO	L	R
NIPPON DENSO	B+	B-	DF	S	D-	-	L	-
POONG SUNG	B+	B-	DF	-	D-	D+	L	-
VALEO	B+	B-	DF	-	D-	D+	L	-

SISTEMA ELÉTRICO/ Electrical System	IGNIÇÃO/ Ignition	AUXILIAR/ Auxiliary	CAMPO/ Field	SAÍDA DE FASE DO ESTRATOR/ Stator Output	NEUTRO/ Neutral	MONITORAMENTO DO CAMPO/ Field Report	COMUNICAÇÃO COM A CENTRAL Computer Input	TERMINAL NÃO CONECTADO/ Disconnected Terminal
BOSCH	IG	AUX	W	-	N	DFM	-	-
BOSCH/ WAPSA	IG	AUX	W	-	N	DFM	-	-
DELCO	IG OU/OR I	-	W	P	N	F	-	-
FORD	B+	-	S OU/OR W	-	-	FR	SIG	-
HITACHI	IG	-	W	-	-	-	-	-
ISKRA	-	-	-	-	-	-	-	-
LUCAS	-	AUX	W	-	-	-	-	-
MAGNETI MARELLI	IG	-	W	P	-	-	-	-
MITSUBISHI	-	-	W	P	-	FR	C	D
NIPPON DENSO	IG	-	W	P	-	FR	C	D
POONG SUNG	-	-	-	-	-	-	-	-
VALEO	IG	-	W	-	N	-	-	-



Linha de produtos Magneti Marelli Retificador



PR520401

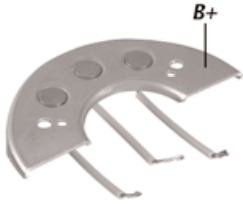

Especificações/ Features:	55A, Diodos / Diodes 3x35A, Triodo não incluído / Triode not included
Substitui/ Replaces:	Bosch: 1.125.715.064, 9.121.080.349, 1.125.715.065, 9.121.080.671, 9.121.080.244, 9.121.080.849
Aplicação/ Application:	DIVERSOS: Tratores Agrale, CBT, Fiat-Allis, Komatsu, Massey Perkins (até 85). Equipamentos Yanmar. MB, SCANIA: Caminhões, Ônibus, Motor marítimo / Estacionário, TOYOTA: Bandeirantes e Utilitários (até 87). VOLVO: Caminhões N10, N12 e Ônibus B58 (até 85). FIAT DIESEL: Todos modelos (até 82). Alternador / Alternator: Bosch: 9.120.080.020/ 031/ 054/ 084/ 091/ 082/ 110/ 125.

PR520402

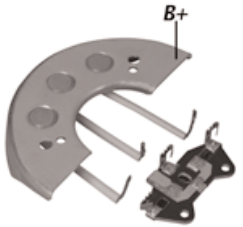

Especificações/ Features:	55A, Diodos / Diodes 3x35A, Triodo incluído / Triode included
Substitui/ Replaces:	Bosch: 1.125.715.064, 9.121.080.349, 1.125.715.065, 9.121.080.671, 9.121.080.244, 9.121.080.849
Aplicação/ Application:	DIVERSOS: Tratores Agrale, CBT, Fiat-Allis, Komatsu, Massey Perkins (até 85). Equip. Yanmar. MB, SCANIA: Caminhões, Ônibus, Motor marítimo / Estacionário, TOYOTA: Bandeirantes e Utilitários (até 87). VOLVO: Caminhões N10, N12 e Ônibus B58 (até 85). FIAT DIESEL: Todos modelos (até 82). Alternador / Alternator: Bosch: 9.120.080.020/ 031/ 054/ 084/ 091/ 082/ 110/ 125.

PR520406

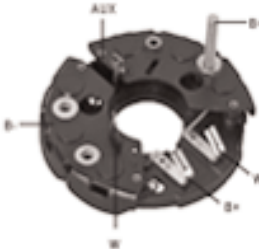

Especificações/ Features:	70A, Diodos / Diodes 6 x 35A Avalanche (Zener) , Parafuso B+ M6 / B+ Post M6
Substitui/ Replaces:	Bosch: 9.121.067.385, 9.120.067.027
Aplicação/ Application:	JOHN DEERE, THERMOKING. Alternador / Alternator: BOSCH: 9.120.067.027, LESTER: 12223, PIC: 220344A, THERMOKING: 5D33839G01, 5D38603G01.

PR520505

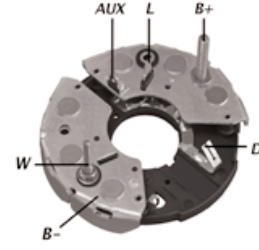

Especificações/ Features:	75A, Diodos / Diodes 6x35A , Parafuso B+ M6x50 / B+ Post M6x50, Parafuso W M5/M4x45 / W Post M5/M4x45, Com trio Diodo / With Diode trio.
Substitui/ Replaces:	Bosch: 9.122.080.638
Aplicação/ Application:	FIAT-ALLIS: Tratores FB80.2 e 100.2, série 4630, 5030, 5060, 6630, 7630, 7830, 8030 (01.97) F 000 LD0 103 K1 75 14, GM: Pick-up D20, D40, D6000, Bonanza, Veraneio (Maxion) com ar-condicionado (03.92) 9 120 080 197 K1 75 14. Alternador / Alternator: BOSCH: F000 LD0-103, 9.120.080.197.

PR520512

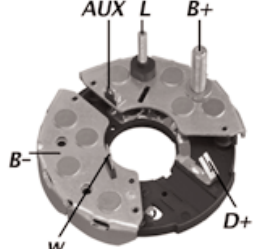

Especificações/ Features:	95A, Diodos / Diodes 8x35A Avalanche (Zener), Parafuso B+ M8x50 / B+ Post M8x50, Parafuso D+ M5x45 / D+ Post M5x45, Terminal W, Com trio Diodo / With Diode trio
Substitui/ Replaces:	Bosch: 1.127.320.692, Cargo: 138165
Aplicação/ Application:	JOHN DEERE, KHD, NEW HOLLAND, IVECO: 75-9A, 80-9A, 80-13A, 80-16A, 90-13A, 90-9A, 110-13A, 130-13A, 130-16A, JI.CASE : 110, 120, 135 com ar condicionado. Alternador / Alternator: BOSCH: 0.120.484.001, 0.120.484.011, 0.120.484.012, 0.120.484.015, 0.120.484.118, 0.120.484.020, 0.120.484.022, 0.120.484.024.

PR520552

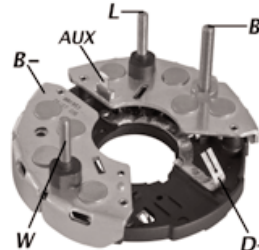

Especificações/ Features:	90A Diodos / Diodes 8x50, Com Trio Diodo / With Diode Trio, Parafuso (Post) W M5 , D+ M5, B+ M6
Substitui/ Replaces:	Bosch: 9.128.040.953, 9.128.040.953J
Aplicação/ Application:	MERCEDES: Caminhão / Truck 94, alternador / alternator Bosch 9.120.180.020, 12V FORD: Bronco, Pegaso Alternador / Alternator: BOSCH: 9.120.180.020J, 9.128.040.953J



PR520440

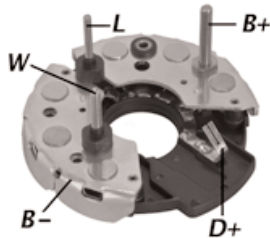

Especificações/ Features:	35A, Diodos / Diodes 6x35A, Paraf. B+ M6x50 / B+ Post M6x50, Paraf. D+ M4x50, D+ Post M4x50, Paraf. W M5x45, W Post M5x45, C/ trio Diodo / With Diode trio.
Substitui/ Replaces:	Bosch: 9.122.080.336
Aplicação/ Application:	MF: Trator MF3640: (Perkins 6358A) (01.73) Caminhões, Chassi para Ônibus OF e OH e Plataforma para Ônibus R, RS, RSD K1 35 28 Caminhões, Microônibus, Motores Estacionários, Industriais, Geradores e Marítimos OM. Alternador / Alternator: BOSCH: 9.120.080.148, 9.120.080.147, 9.120.080.502



PR520444

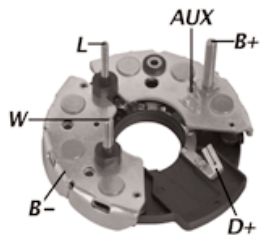

Especificações/ Features:	95A, Diodos / Diodes 6x35A, Paraf. B+ M6x50, B+ Post M6x50, Paraf. D+ M4x50, D+ Post M4x50, Paraf. W M4x45, W Post M4x45, C/ trio Diodo / With Diode trio.
Substitui/ Replaces:	Bosch: 1.127.320.366 / 545 / 344 / 363 / 367 / 546 / 599, 1.127.011.098 / 101.
Aplicação/ Application:	MB: Caminhões 1113, 1313, 1316, 1513, 1516, 2013, 2213, 2216 (OM 352) c/ Dir.Hidr., 1214, 1414, 1614, 1218, 1418, 1618, 1935, 1941 (OM 366, 366A, 447LA, 449A), 2220, 1524, 1525, L709, 712, 1520, 1621, 2020, Ônibus 364, 365, O365, Chassi p/ Ônibus L0812, OF e OH1113, 1313, Oh1318. KOMATSU: Tratores D30E, D50A, D50P. MF: Tratores MF1630, 3640, 5650 MAXION: Retro-escavadeira série 750 e Tratores 9150/ 9170. TOYOTA: Utilitários Bandeirante. DAF, RENAULT, STEYER, SAAB SCANIA. Alternador / Alternator: BOSCH: 0.120.489.027/ 224/ 053/ 192/ 230/ 387/ 388/ 684/ 702/ 707/ 710/ 723/ 726/ 727/ 733/ 757, 0.986.030.660, 0.986.031.190/ 230/ 250/ 251/ 260/ 290/ 310/ 330, 0.986.033.510/ 570, 0.986.034.210/ 350, 9.120.144.122/ 123/ 125/ 127/ 130/ 131/ 132/ 133/ 137.

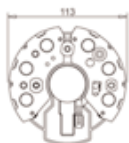

PR520491

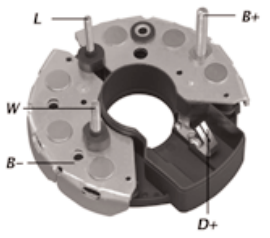

Especificações/ Features:	95A, Diodos / Diodes 6x35A , Paraf. B+ M6x50 / B+ Post M6x50, Paraf. D+ M4x50, D+ Post M4x50, Paraf. W M5x45, W Post M5x45, C/ trio Diodo / With Diode trio.
Substitui/ Replaces:	Bosch: 9.122.080.509
Aplicação/ Application:	J1 CASE: Tratores W18D e W20D (OM 366A) (93 / 94), KOMATSU: Tratores D30E (OM 352), D50A, D50P (OM 352A) (05.75), MASSEY-FER GUSSON: Trator MF3640 (Perkins 6358A), MERCEDES-BENZ: Caminhão 1620 (06.96) Caminhões 1113, 1114, 1117, 1118, 1313, 1314, 1514, 1520, 2014, 2020, 2214 (OM 352) Caminhões 1214, 1218, 1414, 1418, 1614, 1618, 1924, 1929, 1932, 1933, 1934, 1935. TOYOTA: Utilitário Bandeirante. Alternador / Alternator: BOSCH: 9.120.080.181, 9.120.080.183, 9.120.080.219.

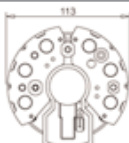

PR520494

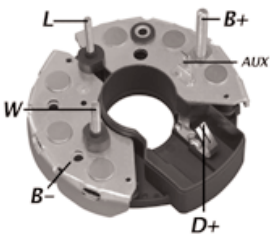

Especificações/ Features:	95A, Diodos 6x35A , Paraf. B+ M6x50 / B+ Post M6x50, Paraf. D+ M4x50, D+ Post M4x50, Paraf. W M5x45, W Post M5x45, C/ trio Diodo / With Diode trio.
Substitui/ Replaces:	Bosch:1.127.320.541, 1.127.011.095
Aplicação/ Application:	SCANIA: Caminhões / Trucks T112 e 142, R112, 113 e 142, DN 11, Ds11 e 14, Motor Marítimo Geradores Ind. MB: Caminhões O365, 812, 1621, 2020, L1625, LG1825,1114,1214,1418. MAXION: Retro-escavadeira série 1175, MF86, Tratores 9070,9075,9090,9110,9130 c/ motor Perkins. MF: Tratores MF1630,3640,5650,5650 Turbo,6845,6855 e 6865,235,265,272,275 ,283,290,292,297,299. KOMATSU: Tratores D30E após 11/78. J. I. CASE: Tratores W36B (após 01/88). Alternador / Alternator: BOSCH: 0.120.489.728/ 730/ 827/ 886/ 944, 9.120.080.114/ 130/ 136/ 137/ 144/ 157/ 159/ 160/ 162/ 166/ 182/ 184/ 187/ 188/ 202/ 207.

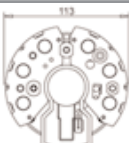

PR520548

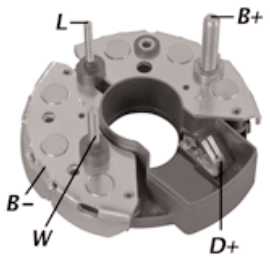

Especificações/ Features:	120A, Diodos 6x50A , Paraf. B+ M8x30 / B+ Post M8x30, Paraf. L M4x19, L Post M4x19, Paraf. W M5x19, W Post M5x19, C/ trio Diodo / With Diode trio.
Substitui/ Replaces:	Bosch: 1127320909; 1127320992; 9127041132; 9127041133, Mercedes: 000 154 7016, Cargo: 133995
Aplicação/ Application:	Mercedes: Caminhões / Trucks Alternador / Alternator: BOSCH: 0.120.489.316

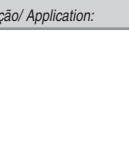

PR520516

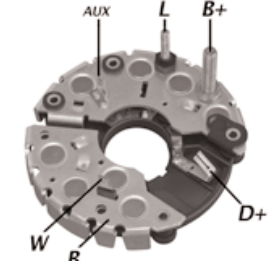

Especificações/ Features:	115A, Diodos 8x50A, Parafuso B+ M8x50 / B+ Post M8x50, Parafuso D+ M5x45, D+ Post M5x45, Terminal W, Com trio Diodo / With Diode trio
Substitui/ Replaces:	Bosch: 1.127.320.708, 1.127.320.731
Aplicação/ Application:	MERCEDES, SAAB, VOLVO, BMW, VOLKSWAGEN, AUDI. Alternador / Alternator: BOSCH: 0.120.469.603/ 610/ 015/ 020/ 021/ 663/ 722/ 723/ 724/ 734/ 735/ 736/ 737/ 738/ 739/ 740/ 741/ 768/ 774/ 813/ 814/ 856/ 857/ 863/ 884/ 903/ 904/ 908/ 929/ 930/ 931/ 932/ 933/ 934/ 953/ 975/ 976/ 977/ 991.

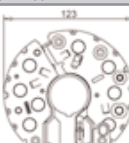



Linha de produtos Magneti Marelli Retificador



PR520524

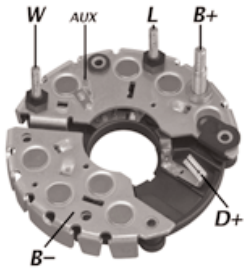

Especificações/ Features:	130A, Diodos / Diodes 8x50A, Paraf. B+ M6/M8x50, B+Post M6/M8x50, Double Thread / Paraf. D+ M5X45, D+ Post M5X45, Terminal W, C/ trio Diodo / With Diode trio.
Substitui/ Replaces:	Bosch: 9.128.041.566.
Aplicação/ Application:	CUMMINS, NAVISTAR 100A . Alternador / Alternator: BOSCH: 6 004 LA9.

PR520528

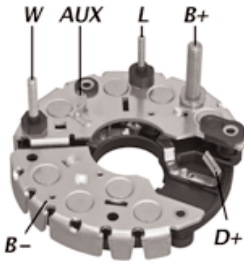

Especificações/ Features:	80A, Diodos / Diodes 8x50A Avalanche (Zener), Paraf. B+ M8/M6x50, B+ Post M8/M6x50, Paraf. D+ M5/M4x45, D+ Post M5/M4x45, Paraf. W M5x45, W Post M5x45, Ø: 120mm
Substitui/ Replaces:	Bosch: 1.127.320.753.
Aplicação/ Application:	MB: Ônibus OF1417, 915, Equipamento com OM 904 LA 4 cilindros. Alternador / Alternator: BOSCH: 0120468143, 0120468145, 0.120.469.101 / 115 / 116 / 117 / 118, 6033G004BY, 6033G3B022, 6033GB3010, 6033GB3019, 6033GB3022, 6033GB3023, 6033GB3027.

PR520465

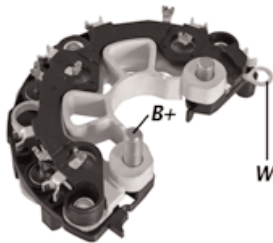

Especificações/ Features:	120A, Diodos / Diodes Avalanche (Zener) 6 x 50A
Substitui/ Replaces:	Bosch: F00M 133 224 / 286
Aplicação/ Application:	VOLKSWAGEN: Caminhão / Truck 16.210 CO; MERCEDES-BENZ: Caminhão / Truck L1622; LS1938; LS2638; O500M; OF1620; OF1721; OH1420; OH1621 LG, 915; 917; 1218; 1418; 1622; 1944; 1114; 1117; 1120; 1124; 1215; 1315; 1317; 1318; 1418; 1518; 1718; 1725; 1728; 2423; 2425; 2428, 712, 814, 817,; EL DETALLE: Caminhão / Truck AO 101 C/ Motor BF 6-913C; IVECO: 70 E 21; VW: 13170, 13180, 15170, 15180, 15190, 17210, 17250, 18310, 23250, 24250, 26260, 31260, 8150, 9150, Constallation17250, 19320, Titan 24250, 31320 Alternador / Alternator: BOSCH: 0 124 555 001; 0 124 555 002; 0 124 555 007; 0 124 555 015, 0 124 655 026, 0 124 655 007, 0 124 055 004

PR520526

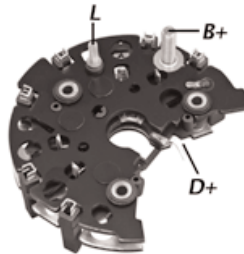

Especificações/ Features:	120A, Diodos / Diodes Avalanche (Zener): 6x50A, Parafuso B+ M8 / B+ Post M8, Com trio Diodo / With Diode trio, Com / With Capacitor
Substitui/ Replaces:	Bosch: 1.127.319.708
Aplicação/ Application:	MERCEDES BENZ, ECOPOWER 90. Alternador / Alternator: BOSCH: 6 004 LA9, 0.123.512.501, 0.123.512.502

PR520495

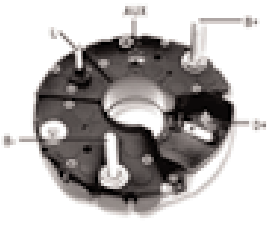

Especificações/ Features:	105A, Diodos / Diodes: 14x35A, 3x35A Trio Diodo, With 3x35A Diode trio, Terminal B+ M8, Terminal B- M6, Terminal D+M4, .
Substitui/ Replaces:	Bosch: 1.127.319.560, 1.127.320.543/ 361/ 379/ 388/ 395/ 653/ 655/ 959, Audi: 049 903 359D, Cargo: 133530, Ford: 613319, 83DB10304AA, M. Marelli: 940 038 360, Mercedes: 1543316/ 4716/ 6616/ 6916, 11541216/ 1516, Scania: 1314207, 1342386, 424968
Aplicação/ Application:	MERCEDES, SCANIA, VOLVO: Caminhões e Ônibus. Alternadores Bosch 28V. Alternador / Alternator: BOSCH: 0.120.469.518, 0.120.469.521, 0.120.469.532, 0.120.469.569. Alternadores 28 V.

PR520549

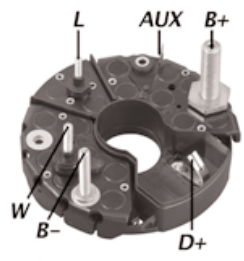

Especificações/ Features:	135A, Diodos / Diodes: 14 x 50A, 3x35A trio Diodo / Diode trio 3x35A, Terminal B+ 7/16' (11mm), Terminal B- M6, Terminal D+ M4, Terminal W M5
Substitui/ Replaces:	Bosch: 1.127.320.920
Aplicação/ Application:	JI CASE: Tratores. Alternadores / Alternators Bosch 28V - 135A. Alternador / Alternator: BOSCH: 0.120.468.028, 0.120.468.055.



PR520553

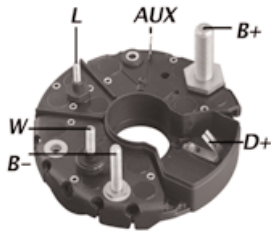

<i>Especificações/ Features:</i>	140A, Diodos / Diodes: 8 x 50A Avalanche (Zener), 3x35A Trio Diodo / Diode trio 3x35A, Term. B+ 7/16" (11mm), Terminal B- M6, Terminal D+ M4, Terminal W M5.
<i>Substitui/ Replaces:</i>	Bosch: 1.127.320.954
<i>Aplicação/ Application:</i>	J1 CASE: Colheadeiras 2155, 2166, 2188, 2366, 2388, 2555. (Cummins 6T 8.3L) (05.97.) Tratores 8910, 8920, 8930, 8940, 8950, (Cummins 6T 8.3L) (05.97.) John Deere. Alternadores / Alternators Bosch 14V. Alternador / Alternator: BOSCH: 0.120.468.028, 0.120.468.055 Não aplicar em alternadores 28V.



PR520554

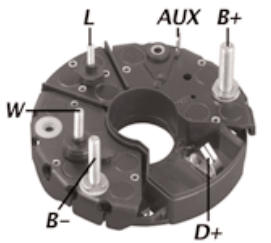

<i>Especificações/ Features:</i>	105A, Diodos / Diodes: 8 x 35A, 3x35A Trio Diodo / Diode trio 3x35A, Terminal B+ M8, Terminal B- M6, Terminal D+ M4, Terminal W M5 Bosch: 1.127.320.955, 1.127.320.951, 1.127.320.980, 1.127.320.981, 1.127.320.602, 1.127.320.924
<i>Substitui/ Replaces:</i>	SCANIA: Caminhões e Ônibus / Trucks and Buses. DAF, KHD, MAN
<i>Aplicação/ Application:</i>	Alternadores / Alternators Bosch 28V - 80A. Alternador / Alternator: BOSCH: 0.120.468.037/ 053/ 115/ 118, 0.120.469.686/ 687/ 895 .

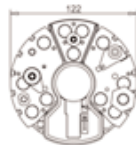

PR520555

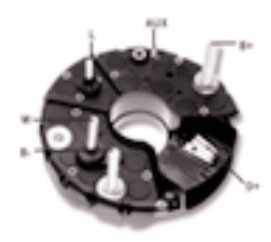

<i>Especificações/ Features:</i>	140A, Diodos / Diodes: 14 x 35A, 3x35A Trio Diodo / Diode trio 3x35A, Terminal B+ M8, Terminal B- M6, Terminal D+ M4, Terminal W M5.
<i>Substitui/ Replaces:</i>	Bosch: 1.127.320.961, Não substitui / No replaces 1.127.320.959.
<i>Aplicação/ Application:</i>	SCANIA, VOLVO, MERCEDES, DAF. Alternadores / Alternators Bosch 28V - 90A. Alternador / Alternator: BOSCH: 0.120.469.522, 0.120.469.749.

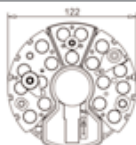

PR520556

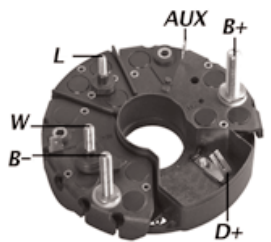

<i>Especificações/ Features:</i>	105A, Diodos / Diodes: 8x35A, 3x35A Trio diodo / Diode trio 3x35A, Terminal B+ M8, Terminal B- M6, Terminal D+ M4, Terminal W M5
<i>Substitui/ Replaces:</i>	Bosch: 1.127.320.968, 1.127.320.904, Scania: 1318551, 1345630, DAF 068092
<i>Aplicação/ Application:</i>	SCANIA: Caminhões e Ônibus / Buses and Trucks DAF, KHD, MAN (USA). Alternador / Alternator: BOSCH: 0.120.469.041, 0.120.469.796, 0.120.469.963, 0.120.469.983. Alternadores / Alternators Bosch 28V - 50A.

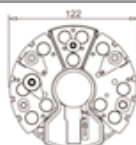

PR520558

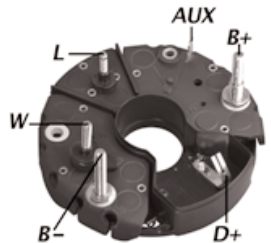

<i>Especificações/ Features:</i>	105A, Diodos / Diodes: 8 x 35A, 3x35A Trio diodo / Diode Trio 3x35A, Terminal B+ M8/M6, Terminal B- M6, Terminal D+ M4, Terminal W M5 Bosch: 1.127.320.977, 1.127.320.590, Scania: 102644, 1344240, 362644.
<i>Substitui/ Replaces:</i>	SCANIA: Caminhões / Trucks e Ônibus / Buses
<i>Aplicação/ Application:</i>	Alternador / Alternator: BOSCH 28V: 0.120.468.037/ 053/ 115/ 118, 0.120.469.686/ 687/ 895. Alternadores / Alternators Bosch 28V - 50A.



PR520559

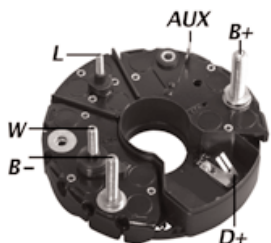

<i>Especificações/ Features:</i>	105A, Diodos / Diodes: 8 x 35A Avalanche (Zener), 3x35A Trio Diodo / Diode Trio 3x35A, Terminal B+ M8, Terminal B- M6, Terminal D+ M4, Terminal W M5, Com / With Capacitor
<i>Substitui/ Replaces:</i>	Bosch: 1.127.320.989, 1.127.320.928, 1.127.320.946, 1.127.320.956, 1.127.320.969, IBR 989, Scania: 102644, 1344240, 36264.
<i>Aplicação/ Application:</i>	MERCEDES: Caminhões / Trucks 609, 611, 614, 709, 711, 714, 809, 811, 814, 914, 917, 1114, 1320, 15140. SCANIA: Chassis e Ônibus / Bus OF1315, OF1318, OH1418 e 1635 OF1113 (OM352), Caminhões / Trucks L1117 (USA), LPS1525 e Ônibus / Bus O390D. Chassis para Ônibus / Bus OH1318. Caminhões / Trucks MT-DS11.94, 95, 96, 97, DS14.52, DSC11.56, 57, 58, 14.57, 61, 62, 63 e outros / others. VOLVO: Caminhões e Ônibus / Trucks and Buses. IVECO: KHD. Alternador / Alternator: BOSCH: 0.120.468.037/ 053/ 107/ 113/ 114/ 115/ 118/ 131/ 137/ 149, 0.120.469.013/ 895, 0.986.037.770, 6033.GB3.006/ 008/ 033/ 034/ 054. Alternadores / Alternators Bosch 28V - 80A.

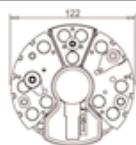



Linha de produtos Magneti Marelli Retificador



PR520560

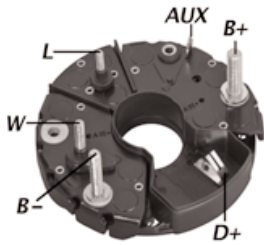

Especificações/ Features:	90A, 8x35 Diodos / Diodes Avalanche (Zener) 35A , Avalanche (Zener) Diodes 35A, Trio Diodo / Diode Trio Parafusos B+ M8, B+ Post M8
Substitui/ Replaces:	Bosch: 1.127.320.995, 1 127 320 928, 1 127 320 946, 1 127 320 969, 1 127 320 989, Cargo: 136832, M. Marelli: 940 038 364, Mercedes: 11542116, Scania: 1387615
Aplicação/ Application:	IVECO: Caminhões / Trucks 190-36, 190-36P, 190-36T, 190-38, 190-38PT, 190-36, 220-36, 240-36, 240-36p, 260-36. MB: Ônibus / Buses OF 1113, Oh 1113, 917.VOLVO: Caminhões / Trucks NL 10, NL 12, Chassi p/ Ônibus b12. Alternador / Alternator: BOSCH: 0.120.468.094, 0.120.469.025, 0.120.469.014, 0.120.469.749, 0.120.469.026/ 526/ 532.

PR520407

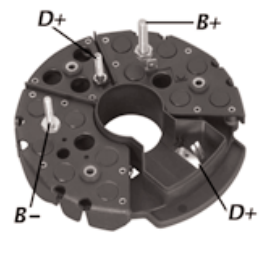

Especificações/ Features:	95A, 12x35A Diodos / Diodes 12x35A, Paraf. B+1/4x45 , B+Post 1/4x45, Paraf. D+ 3/16x30, B+ Post 3/16x30, Paraf. W 3/16x40 / W Post 3/16x40
Substitui/ Replaces:	Bosch: 1.121.456.065.
Aplicação/ Application:	CARGO: Caminhões / Trucks 1113 / 1114 / 1117 / 1215 / 1218 / 1313 / 1314 / 1317 / 1415 / 1418 / 1514 todos / all. 1419 / 1619 / 2319 / 35300 (após 10.90). F6000 / 7000 (após 06.87). Alternador / Alternator: BOSCH: 9.120.456.004, 9.120.456.005, 9.120.456.013, 9.120.456.024, 9.120.456.025. Alternadores / Alternators Bosch 28V - 70A.

PR520496

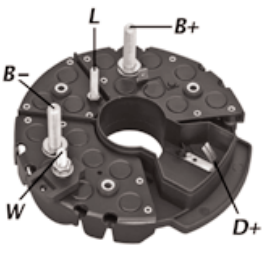

Especificações/ Features:	140A, 14x50A Diodos / Diodes, 3x35A trio Diodo / 3x35A Diode trio, Paraf. B+ M8 / B+ Post M8, Paraf. B- M8 , B- Post M8, C/ Resistor, With resistor.
Substitui/ Replaces:	Bosch: 1.127.320.547, 1.127.320.550, 1.127.320.571, Cargo: 136581, Mercedes: 1545116, 1545416
Aplicação/ Application:	MB: Ônibus e Caminhões / Buses and Trucks, SCANIA: Ônibus / Bus e Chassi F112HL, 113, K113CL, K113TL, L113CL, S113AL, S113CL, VAL MET: Tratores / Tractors com altern. 90A. VME: Caminhões fora de estrada / Out of road trucks., VW: Caminhões / trucks 16.180 e 16.210 c/ mot. MWM 6.10 (83 a 86). RECROSUL: Chassi p /Ônibus. RANDOM: Caminhões fora de estrada / Out of road trucks, MAFERSA: Ônibus / Bus M210 e M240 (após 91), Trolebus. MAXION: Motor 4236. VOLVO: Ônibus / Bus B58 e B10M. Alternador / Alternator: BOSCH: 0.120.488.158/ 159, 9.120.456.001/ 003/ 008/ 010/ 011/ 012/ 014/ 028/ 031/ 032/ 033/ 034/ 036/ 037/ 038/ 039/ 040/ 041/ 042/ 043/ 044/ 046/ 047/ 048/ 050, F006 LDO-800.

PR520557

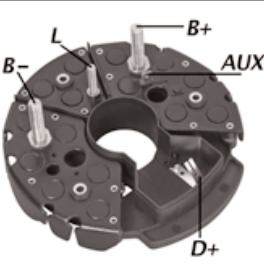

Especificações/ Features:	140A, 12x50A Diodos / Diodes, 3x35A trio Diodo / Diode trio 3x35A, Parafuso B+ M8 / B+ Post M8, Com Resistor / With resistor
Substitui/ Replaces:	Bosch: 1.127.320.973, 9.121.456.212, Mercedes: 11540816, Scania: 1347012
Aplicação/ Application:	MB: Caminhões e Ônibus, IVECO: 3801029, RENAULT: Agora, Ares, Iliade, Tracer, R332 Line1, SCANIA: K113, L113, N113, F94, K124EB Bus, K124IB BUS, VOLVO: B10M, B7L Alternador / Alternator: BOSCH série T1 (140A): 0.120.689.535/ 562, 9.120.456.049/ 052.

PR520449

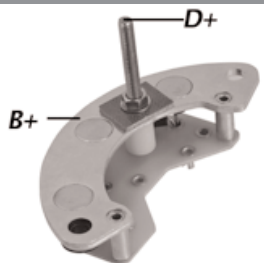

Especificações/ Features:	55A, 3x35A Diodos / Diodes
Substitui/ Replaces:	Bosch: 9.121.080.374
Aplicação/ Application:	MWM, VALMET, CATERPILLAR. Alternador / Alternator: Bosch: 9.120.080.045/ 049/ 057/ 085/ 094/ 107/ 138/ 146.

PR520493

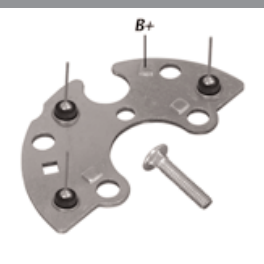

Especificações/ Features:	60A, 3x35A Diodos / Diodes
Substitui/ Replaces:	Bosch: 9.121.450.313 , Wapsa: 415-29.
Aplicação/ Application:	Ford: Caminhão Cargo 1218 / 1415 / 1418 / 1519 / 1521 / 1618 / 1621 / 2218 / 2319 / 2321 / 3021 / 3223 c/ motor FORD 6.6 / 7.8 litros. Alternador / Alternator: WAPSA: ARC14096, ARC16097. BOSCH: 9.120.450.080, 9.120.450.083, 9.120.450.128, 9.120.450.006.

retificador

213



PR520499

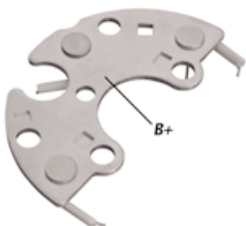

Especificações/ Features:	60A, 3x35A Diodos / Diodes
Substitui/ Replaces:	Bosch: 9.121.450.574, 9.120.450.073, 9.120.450.129, 9.120.450.133, 9.120.450.134.
Aplicação/ Application:	Ford: Cargo 1218/1415/1418/1618/2218 c/ motor FORD 6.6 litros, NEW HOLLAND: Colheitadeira 8040/8055, VOLKSWAGEN: Caminhão / Truck 16.170/14.170/14.210/16.210 com motor cummins Série (Ref. original 9120450013). Caminhão / Truck 13.210/15.210/22.210 com cummins série C. Alternador / Alternator: BOSCH: 9.120.450.073/ 129/ 133/ 134/ 014/ 137, WAPSA : AKC16123, AKC14122.

PR520460

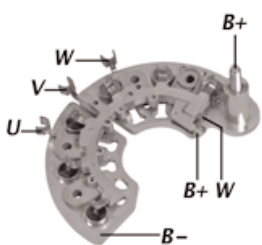

Especificações/ Features:	120A, Diodos / Diodes Avalanche (Zener) 6 x 50A
Substitui/ Replaces:	Delco: 10494503
Aplicação/ Application:	Chevrolet, GMC Alternador / Alternator: DELCO: 10464439 , 10464455, 10464459, 10464478, 10464481, 10464483, 10464484, 10464490, 10464491, 10480229, 10480241, 10480271, 10480285, 10480326, 10480388, 10480411, 10480476, 10480479, 10480497, 15087020, 15087021 15087023, 15755616W, 15768829, 25744164W, 321-1748, 321-1784, 321-1798, 321-1799, 321-1811, 321-1815, 321-1819, 321-1847, 321-1850, 321-1852, 321-1853, 321-1857

PR520416

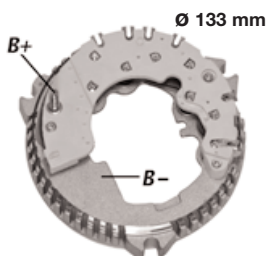

Especificações/ Features:	95A, Diodos / Diodes 8x35A, Parafuso B+: M6x22A , B+ Post , M6x22A, Ø:133 mm, Com / With Capacitor
Substitui/ Replaces:	Ford: F5AZ-10346-BA, F1TZ-10346-B,F5AZ-10304-BA.
Aplicação/ Application:	Ford: Carros de passeio, Caminhões Leves Alternador / Alternator: Ford: F0CZ-10346-A, F0CZ-10346-C, F0DZ-10346-A, 1160931FD, E9DF-10300-CA, F07F-10300-AA, F07U-10300-AA, F0CF-10300-AA, F0CU-10300-AA, F0CZ-10346-A, F0CZ-10346-C, F0DZ-10346-A, F0DZ-10346-D, F0FV-10300-AA, F0VY-10346-A, F0VY-10346-B, F13U-10300-AC, F13Z-10346-A.

PR520417

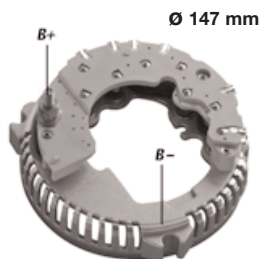

Especificações/ Features:	130A, Diodos 8x50A / Diodes 8x50A, Parafuso B+: M6x22, B+ Post: M6x22, Ø:147 mm, Com / With Capacitor
Substitui/ Replaces:	Ford: F5AZ-10304-AA, FODU-10A366-DAIP
Aplicação/ Application:	FORD: Carros de passeio / passenger vehicles, Caminhões Leves / Light Trucks Alternador / Alternator: Ford: 94BB10300AE, F3AU10300BA, F5AU10300AA, 96BB10300AB, F3AU10300CA, F5PU10346CA , 97BB10300AC, F3DU10300BB, F5PU10346PA, F0DF10300BA, F4DU10300AA, F5PZ10346PA, F0DU10300BC, F4DU10300BA, F5PZ10346PARG, F0DZ10346B, F4DU10300CA, F5RU10300BA, F0DZ10346C, F4DU10300DA, F5UU10300AA, F0DZ10346E , F4PU10300AA , F5UU10300BA, F1DU10300AD, F4PU10346BA, F65U10300BB, F1DZ10346A, F4PU10346DA, F6AU10300AA.

PR520422

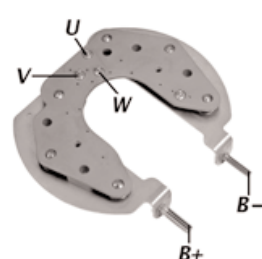

Especificações/ Features:	120A, Diodos / Diodes 6 x 50A
Substitui/ Replaces:	Ford: D2OZ10304A; F0TZ-10304-A; GY-1026-A
Aplicação/ Application:	FORD: Carros de Passeio / Passenger Vehicles , Caminhões Leves / Light Truck Alternador / Alternator: Ford: D9AF10300CA, E3TF10300AB, E4LF10300CA, E6DF10300CA, E9TF10300AA, F0TU10300AA, LESTER: 7072, 70729, MOTORCRAFT: GL215, 250118

PR520423

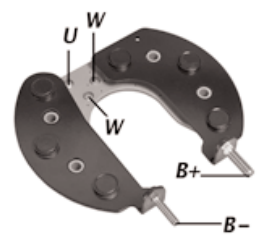

Especificações/ Features:	120A, Diodos / Diodes 6 x 50A
Substitui/ Replaces:	Ford: D4VY10304A; E2HZ10304B; F0HZ-10304-A; GY-1302-B; GY-1345-A
Aplicação/ Application:	FORD: Carros de Passeio / Passenger Cars, Caminhões Leves / Light Trucks Alternador / Alternator: Ford: D3VF-10300-AA, D3VF-10300-AB, D3VF10346-A, D3VF-10346-BA, D3VY-10346-A, D4TF-10300-DA, D4TZ-10346-A, D50F-10300-BA, D5UF-10300-AA, D5ZF-10300-BA, D6UF-10300-AA, D70F-10300-BA, D7UF-10300-BA, D7VF-10346-AA, D7VZ-10346-A, D7ZF-10300-BA, D7ZF-10300-CA, D8VF-10300-BA, D8VF-10346-BA, D9BF-10300-AA, D9VY-10346-D, E1BF-10300-CA, E1NF-10300-AA, E1VF-10300-AA, E1VF-10346-AA, E1VZ-10346-A, E7PF-10346-RA, E7PZ-10346-A, E7TF-10300-GA, E8DF-10300-CA, E8DZ-10300-B, E8PF-10346-BA, E8PZ-10346-B, E9DF-10300-EA, E9PF-10346-DA, E9PZ-10346-E, EZHT-10346-EB, F0DU-10300-DA, F0PU-10346-RA, F0PZ-10346-C, F0UU-10300-BA, GL-108, GL-108A, GL-203, GL-203A, GL-203B, GL-256, GL-256A, GL-286

retificador

214



Linha de produtos Magneti Marelli Retificador



PR520502

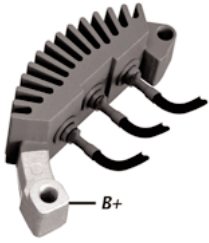

<i>Especificações/ Features:</i>	150A, Diodos 3x50A / Diodos 3x50A, Placa Positiva / Positive Plate.
<i>Substitui/ Replaces:</i>	Leece Neville: 97084.
<i>Aplicação/ Application:</i>	Caminhão corpo de bombeiro. Alternador / Alternator: LESTER 7613.

PR520503

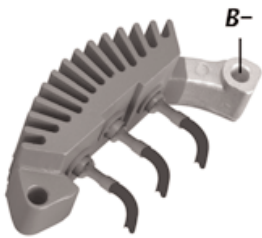

<i>Especificações/ Features:</i>	150A, Diodos 3x50A / Diodos 3x50A, Placa Negativa / Negative Plate.
<i>Substitui/ Replaces:</i>	Leece Neville: 97085.
<i>Aplicação/ Application:</i>	Caminhão corpo de bombeiro. Alternador / Alternator: LESTER:7613, PIC: 270423.

PR520412

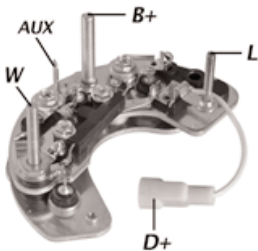

<i>Especificações/ Features:</i>	85A, Diodos: 6x35 Amp. Dish, Com Trio Diodo / With Doide Trio Ø ext: 115 mm, Paraf/post B+: M6 x 42 mm, Paraf/post D+: M4 x 19 mm, Paraf/post B -: M5 x 56 mm.
<i>Substitui/ Replaces:</i>	Lucas: 80150; 80367; 84469; 84469H; 84886; 84886E; UBB137
<i>Aplicação/ Application:</i>	Ford: Trator, Fiesta com alternador Lucas. LAND ROVER. Alternador / Alternator: LUCAS: 24129, 24161, 24616A, 24206, 24207, 24217, 24220, 24221, 24221A, 24221D, 24240, 54022058A, 54022058B, 54022060A, 54022097A, 54022097B, 54022162, 54022191, 54022192, 54022193, 54022197, 54022229, 54022235, 54022242, 5402244, 5402255, 54022262, 54022282, 54022306, 54022309, 54022379, 54022483, 54022552, 54022616, 54022635, 54022648, 54022663, 54022666

PR520413

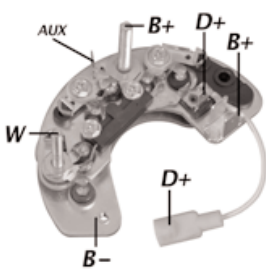

<i>Especificações/ Features:</i>	85A, Diodos / Diodos 6 x 35A, C/ Trio Diodo / With Diode Trio
<i>Substitui/ Replaces:</i>	Lucas: 80556; 84201; 84422; 84455; 84499; 84499F; UBB133; UBB135; UBB141
<i>Aplicação/ Application:</i>	LAND ROVER: Range Rover 3.5; Defender 2.5 Diesel; Land Rover 2.5 FORD: Escort; Fiesta; Granada 1.8, 2.0; Orion; Scorpio; Sierra; Transit., Massey Ferguson: tratores; New Holland: tratores, MOTORES: Perkins: motores Alternadores / Alternators: LUCAS: 24129, 24145, 24145A, 24145D, 24156, 24157, 24157AVE, 24158, 24161, 24161A, 24169, 24198, 24198A, 24198B, 24198E, 24199, 24199A, 24199B, 24200, 24200A, 24208, 24240, 24245, 24246, 24246B, 24256, 24256A, 24256B, 24256C, 24256D, 24273, 24273A, 24274, 24274D, 24276, 24277, 24294, 24294B, 24327, 24327A, 51022337D, 54022053/ 054/ 058A/ 058B/ 059/ 060A/ 096/ 097A/ 097B/ 108/ 109/ 162/ 167/ 178/ 182/ 186/ 188/ 191/ 192/ 193/ 193/ 195/ 196/ 196B/ 206/ 211/ 212/ 214/ 217/ 218/ 219/ 220/ 225/ 225A/ 226/ 227/ 228/ 229/ 234D

PR520428

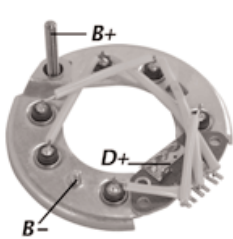

<i>Especificações/ Features:</i>	85A, Diodos 6x35A / Diodos 6x35A, Com Trio Diodo / With Doide Trio
<i>Substitui/ Replaces:</i>	Lucas: 352.13.672, 352.13.437.
<i>Aplicação/ Application:</i>	Ford: Ford Pick-up F 1000, Caminhão / Truck F350, PERKINS: Motor Prima, RENAULT: Clio 1.6, Trafic TA12, TA52, T312 e T352. Alternador / Alternator: 35213845, 35213680, 35213670, 35214170, 7702099331, 7702099330, 91TR-10300A, 9120080231.

PR520429

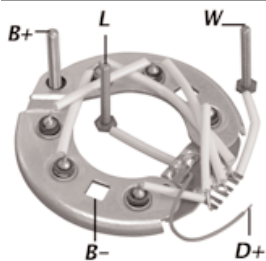

<i>Especificações/ Features:</i>	85A, Diodos 6x 35A / Diodos 6x 35A, Com Trio Diodo / With Doide Trio
<i>Substitui/ Replaces:</i>	Lucas: 352.13.894.
<i>Aplicação/ Application:</i>	Ford: Ford F 1000, F 4000, Caminhão / Truck F350. Alternador / Alternator: 35213855, TNM 903015RA.

retificador 215



PR520470

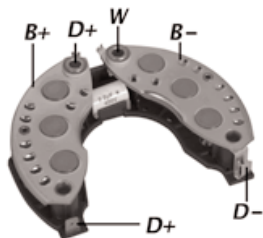

<i>Especificações/ Features:</i>	85A, Diodos 6x30A / Diodes 6x30A, Com Trio Diodo e Capacitor / With Diode Trio and Capacitor.
<i>Substitui/ Replaces:</i>	Valeo / P.Rhone: 103556, 103551, 181155, Valeo: A523726A, NC 135, NC 730, 593188, 593195, 593199, Cargo: 131701, Lucas: 21225389, UBB 235, UBB255, M. Marelli: 940 038 305
<i>Aplicação/ Application:</i>	VOLVO: Penta, PEUGEOT, RENAULT: Espace 2.1 td; R21 td, GTD, R25 turbo d, DX R20 td, GTD; R19 1.8i Alternador / Alternator: Valeo: A12N2M, A13N1M100605, A13N2M100606, 208121, 208124, 208399, 204401, 208402, 100605, 100606, 100879, 101218, 101822, 101823, 102341, 102794, 103141, 2102341, 2102794, 2181693, 2181695, 2181757, 2181760, 2181762, 2541133, 2541191, 2541199, 2541208, 2541218, 2541768, 2541773, 436352, 592769, 592775, A13N28M102794, A13N33M103233, A13N34104551, A13N35M103141, A13N35M103141, A13N36M100879, A13N5101823, A14N118M181991, A14N119M180620, A14N122N2518061, A14N137M592775, A13N165, A13N186M, A13N190, A13N281, A13N282, A14N114T, A14N115M, A14N116M, A14N137, A14N177M, A14N206M, A14N43M, A14N44M.

PR520481

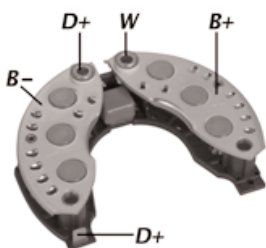

<i>Especificações/ Features:</i>	120A, Diodos 6x50A / Diodes 6x50A, Com Trio Diodo / With Trio Diode, Com Capacitor / With Capacitor
<i>Substitui/ Replaces:</i>	Valeo Paris Rhone: 101227, 104269, Valeo: NC137, Cargo: 131568, Lucas: 21225416, UBB 236, M. Marelli: 940 038 306
<i>Aplicação/ Application:</i>	SCANIA, PEGASO Alternador / Alternator: Valeo: 100422, 2102334, 592774, A13N45T, 102334, 2105111, 99755, A14N133, 105111, 2105112, A13N11, A14N135, 105112, 2541145, A13N245, A14N39, 2099755, 2541147, A13N44T, A14R33, 2100442, PIC: 208135, LESTER: 12120



DESIGNAÇÕES DE TERMINAIS/ Terminal Designations

POSITIVO DA BATERIA/ Battery Positive	NEGATIVO DA BATERIA/ Battery Negative	BOBINA DE IGNIÇÃO/ Ignition Coil	POSITIVO BOBINA IMPULSORA/ Pickup Coil Positive	NEGATIVO BOBINA IMPULSORA/ Pickup Coil Negative	TERMINAL NÃO CONECTADO/ Disconnected Terminal	POSITIVO SENSOR HALL/ Positive Hall Sensor	NEGATIVO SENSOR HALL/ Negative Hall Sensor	SINAL SENSOR HALL/ Hall Sensor Signal	RPM
B+	B-	C	P+	P-	N/C	HALL +	HALL -	HALL INPUT	TACO
B+	B-	C	P+	P-	-	-	-	-	-
B+	B-	C	P+	-	-	-	-	-	-
B+	B-	C	P+	P-	-	-	-	-	-



Linha de produtos Magneti Marelli
Módulo de ignição

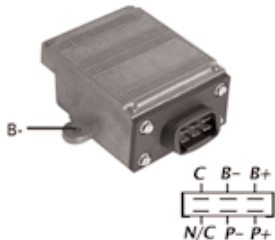

Especificações/ Features:	Sistema: Magnético / Magnethic Pick-up.
Substitui/ Replaces:	Bosch: 9.220.087.004, 9 220 087 005, 9 220 087 006, BM 100.
Aplicação/ Application:	GM: Caminhões / Trucks 11000, 12000, 13000, 14000, 19000, 21000, 22000, C20,C40,C60,C70,C90, Caravan 2.5, 4.1, Chevette 1.4,1.6, Hatch 1.4, 1.6 Chevy 500, 1.6, Ipanema 1.8, 2.0, Kadett 1.8,GS 2.0, Marajo 1.4, 1.6, Opala 2.5, 4.1, Fiat: 147 1.3, pick-up 1.3 Fiorino 1.3, furgão 1.3,1.5, pick-up 1.3, 1.5, Elba 1.3,1.5, Oggi 1.3, Panorama 1.3, Premio 1.3,1.5, Spazio 1.3, Uno 1.3, 1.5, Mille 1.0, Ford: Bellina II 1.8, Del rey 1.8, Escort 1.3, 1.6, 1.8, Pampa 1.6, 1.8, 1.6 4x4, Royale 1.8, 2.0, Verona 1.6, 1.8, Versailles 1.8, 2.0, Gurgel: Tocantins 1.6L, TR VW: Apollo 1.8, Brasília 1.3, Fusca 1.3, 1.6, Gol 1.3, 1.6, 1.8, Kombi 1.6, Parati 1.6, Passat 1.6, 1.8, Quantum 1.8,20, Santana 1.8,2.0, Transporter 1.6, Voyage 1.5, 1.6.

linha de
produtos

**MAGNET
MARELL**

linha
t ermica



Linha de produtos Magneti Marelli
Linha térmica



Modelo	Motor	Ano	Ref. Behr	Código MM	Nº original	TECH	HxLxE (mm)	Bloco	Intercooler	Pag.
--------	-------	-----	-----------	-----------	-------------	------	------------	-------	-------------	------

FORD

RADIADORES / RADIATORS / RADIADORES

Cargo 815 (8 TON.)	Cummins B5.9	02/...	A61133	RMMMA61133	YC458005AB	CuZn	500x625x47	A58121MM	A192953MM	230
Cargo 815e/ 915e (Eletrônico EURO III)	Cummins B5.9	05/...	G8441	RMMG8441	4C458005AD	CuZn	740x537x47	-	RMMG8232	230
Cargo 1317e/ 1517e (Eletrônico EURO III)	Cummins B5.9	02/...	G8443	RMMG8443	4C458005BE	CuZn	706x625x47	RMM53357	-	230
Cargo 1717e (Eletrônico EURO III)	Cummins B5.9	02/...	G8460	RMMG8460	4C458005DD	CuZn	706x625x47	RMM53357	-	230
Cargo 1722e / 2422e / 2622e / 4331 MaxTon	Cummins C8.3	06/...	N9161001	RMMN9161001	6C458005BB	CuZn	840x616x70	T3344001MM	RMMN8795001	230
Cargo 2630 / 4030	Cummins C8.3	94/02	49233	RMM49233	2UC121253 / 98HU8005LA 98HU8005LB	CuZn	746x625x47	-	A192824MM	230

INTERCOOLERS / INTERCOOLERS / INTERCOOLERS

Cargo 815 (8 TON.)	Cummins B3.9	02/...	A192953	A192953MM	XC456K775AA/AB	AB	568x376x50	-	RMMMA61133	230
Cargo 815e / 915e (Eletrônico EURO III)	Cummins B3.9	05/...	G8232	RMMG8232	4C456K775AC	AB	501x372x50	-	RMMG8441	230
Cargo 1215 / 1415 / 1422 / 1617 / 1622 / 1721 / 2422 / 2425	Cummins B5.9	87/01	A192824	A192824MM	2RT117249A XC456K775BA	AB	588x624x52	-	RMM49233	230
Cargo 1217 / 1416 / 14/17 / 1421 / 1516 / 1617 / 1721 / 1722 / 1731 / 2422 / 2425 / 2622 / 2625 / 2630 / 2631 / 4030 / 4031	Cummins B5.9/ C8.3	02/...	C0478002	RMMC0478	2C456K775A	AB	588x632x52	90401MM	-	230
Cargo 1622 / 2422 / 2425 / 2625	Cummins C8.3	91/06	C0479002	C0479MM	2C456K775BA	AB	588x632x52	-	-	230
Cargo 1722e / 2422e / 2622e / 4331 MaxTon	Cummins C8.3	06/...	N8795001	RMMN8795001	6C456K775AA	AB	584x632x50	-	RMMN9161001	230
F-12000 / F-14000	Cummins B5.9	98/05	53354	RMM53354	XC3Z6K775AA	AB	754x657x40	-	-	231

BLOCOS / CORES / PANALES

RADIADORES / RADIATORS / RADIADORES

Cargo 815 (8 TON.)	Cummins B3.9	02/...	A58121	A58121MM	-	CuZn	500x625x47	-	RMMMA61133	231
Cargo 1217 / 1416 / 14/17 / 1516 / 1421 / 1617 / 1716 / 1621 / 1721 / 1717e / 1317e / 1517e	Cummins B5.9	01/02	53357	RMM53357	-	CuZn	706x625x47	RMMG8460	RMMG8443	231
Cargo 1722e / 2422e / 2622e / 4331 MaxTon	Cummins C8.3	06/...	T3344001	T3344001MM	-	CuZn	840x615x70	-	RMMN9161001	231

INTERCOOLERS / INTERCOOLERS / INTERCOOLERS

Cargo 1215 / 1415 / 1422 / 1617 / 1622	Cummins B5.9 / C8.3		90401	90401MM	-	AB	588x624x52	RMMC0478	-	231
--	---------------------	--	-------	---------	---	----	------------	----------	---	-----

IVECO

RADIADORES / RADIATORS / RADIADORES

Cavalino 450 E 32 T	Iveco Cursor 8 320cv	06/...	R5022001	RMMR5022001	503346759 EB 50603	CuZn	806x615x70	-	R5023001MM	ND
Stralis	Iveco Cursor 13 380 / 420cv	07/...	8MK376721791	RMM376721791	504011119	AB	900x748x42	-	376724271MM	231

INTERCOOLERS / INTERCOOLERS / INTERCOOLERS

Cavalino 450 E 32 T	Iveco Cursor 8 320cv	06/...	R5023001	R5023001MM	503346760	AB	632x588x52	-	RMMR5022001	231
Stralis	Iveco Cursor 13 380 / 420cv	07/...	8ML376724271	376724271MM	504015564	AB	772x652x52	-	RMM376721791	231

DEFLETORES / SHROUD / DEFLETORES

Cavalino 450 E 32 T	Iveco Cursor 8 320cv	06/...	R5026001	R5026001MM	50346761 EB 506038	-	-	RMMR5023001	RMMR5022001	231
---------------------	----------------------	--------	----------	------------	--------------------	---	---	-------------	-------------	-----

MERCEDES-BENZ / DAIMLER CHRYSLER

RADIADORES / RADIATORS / RADIADORES

CAMINHÕES / TRUCKS / CAMIONES

1215 C / L-1218 EL / 1318 EL	MB OM-904	99/04	57054	RMM57054	693.500.73.01	CuZn	450x615x47	53358MM	53672MM	231
1938 S / 1944	MB OM-457	01/06	67143	RMM67143	693.500.75.01	AB	974x668x42	E1017MM	67159MM	231
2423 B / 2423 K	MB OM-906	99/...	94546	RMM94546	693.500.74.01	CuZn	617x616x47	-	87940MM	232
2428 Canavieiro	MB OM-906	99/...	A5824	RMMA5824	693.500.00.01	CuZn	617x615x70	-	87940MM	232
Atego 1315 / 1418 / 1518 / 1718	MB OM-904	04/...	N8900001	RMMN8900001	970.500.04.03	AB	570x558x40	-	N9099001MM	232
Accelo 715 C / 915 C	MB OM-612 / OM-904	04/...	G4743	RMMG4743	979.500.02.03	AB	504x474x40	G7555MM	G8700MM F7226MM	232
Axor 2035 / 2040 / 2044 / 2540 / 2640	MB OM-457	05/...	R7998001	RMMR7998001	940.500.0703	AB	974x668x40	-	R7994001MM	232
L-1218 / L-1418 / L-1620 / LK-1620	MB OM-904 / OM-366	97/05	A152022	RMMMA152022	695.500.70.01	CuZn	544x615x47	A252022MM	A192039MM	232
L-1620	MB OM-906	06/...	94546	RMM94546	693.500.74.01	CuZn	617x616x47	-	87940MM	232
L-1622	MB OM-924	01/05	A5826	RMMMA5826	695.500.72.01	CuZn	617x616x47	-	A5832MM	232

Obs.: AB - Alumínio brasado
AE - Alumínio expandido
CuZn - Cobre/ Latão
ND - Desenho não disponível



Modelo	Motor	Ano	Ref. Behr	Código MM	Nº original	TECH	HxLxP (mm)	Bloco	Intercooler	Pag.
L-709	MB OM-364	88/93	A150539	RMMA150539	688.500.04.03	CuZn	475x510x40	A250539MM	-	232
L-712 / L-914	MB OM-904	98/04	53356	RMM53356	688.500.71.01	CuZn	450x615x47	53358MM	53672MM	232
LS 1634/45	MB OM-447	02/06	A5821	RMMA5821	695.500.00.01	CuZn	1000x704x47	-	A5829MM	232
LS-1938 / LS-2638	MB OM-457	98/06	53359	RMM53359	696.500.70.01	CuZn	1000x706x47	-	53342MM	232
Sprinter 310 / 312	MB OM-014	97/00	55393	RMM55393	901.500.33.00	AB	680x408x42	-	-	233
Sprinter 311 / 313	MB OM-611	00/...	D4516	RMMD4516	901.500.36.00	AB	680x408x42	-	-	233

ÔNIBUS / BUS / AUTOBUS

LO-610	MB OM-364 109cv	01/03	C0463	RMCC0463	688.500.00.01	CuZn	450x616x23	-	C0464MM	233
LO-809	MB OM-364	88/93	A150539	RMMA150539	688.500.04.03	CuZn	475x510x40	A250539MM	-	232
LO-814 / LO-914	MB OM-364 136cv	96/02	L0826	RMML0826	668.500.01.02	AB	570x558x42	-	L0212MM	233
O-400	MB OM-457 360cv	94/97	A152138	RMMA152138	664.501.91.01	CuZn	903x703x47	-	-	233
OF-1318	MN OM-366 170cv	89/98	A150560	RMMA150560	384.500.70.03	CuZn	660x674x40	A250555MM	-	233
OF-1417 / LO-914 / LO-915	MB OM-904	98/...	49212	RMM49212	384.500.71.01	CuZn	450x615x47	53358MM	53672MM	233
OF-1721	OM-366	97/04	A152022	RMMA152022	695.500.70.01	CuZn	544x615x47	A252022MM	49200MM	233
OF-1722 / OF-1418	MB OM-924 / 904	02/...	A5826	RMMA5826	695.500.72.01	CuZn	617x616x47	-	A5832MM	233
OH-1621	MB OM-366 204cv	97/05	53670	RMM53670	382.501.76.01	CuZn	810x658x47	-	A192153MM	233

RADIADORES SEM LATERAIS / RADIATORS WITHOUT SUPPORTS / RADIADORES SIN SUPORTES

1723	MB OM-366	98/02	61015	61015MM	-	CuZn	617x615x47	-	RMMA5826	233
L-1218 / L-1418 / L-1620 / LK-1620	MB OM-904 / OM-366	97/04	57533	57533MM	-	CuZn	544x615x47	A252022MM	A152022MM	234
L-709 / LO-809	MB OM-364	88/93	57535	57535MM	-	CuZn	475x510x40	A250539MM	-	234
L-712 / L-914	MB OM-904	98/04	61014	61014MM	-	CuZn	450x615x47	53358MM	53356MM	234

INTERCOOLERS / INTERCOOLERS / INTERCOOLERS

CAMINHÕES / TRUCKS / CAMIONES

1723	MB OM-366	98/02	49229	49229MM	693.501.71.01	AB	420x552x52	-	RMM57054	234
1215 C / L-1218 / L-1418 / 1718 M	MB OM-904	99/07	A5833	A5833MM	688.501.71.01	AB	450x607x50	-	-	234
1938 S / 1944	MB OM-457	01/06	67159	67159MM	693.501.74.01	AB	630x892x62	G9114MM	RMM67143	234
2423 B / 2423 K / 2428	MB OM-906	99/...	87940	87940MM	693.501.73.01	AB	600x607x50	G9118MM	RMM94546	234
712 C / 914 C / 1215 C	MB OM-904	98/04	53672	53672MM	688.501.71.01	AB	450x607x50	-	-	234
Accelo 715 C	MB OM-612	04/...	G8700	G8700MM	979.500.00.03	AB	550x272x52	-	RMMG4743	234
Accelo 915 C	MB OM-904	04/...	F7226	F7226MM	979.500.01.03	AB	550x432x52	-	RMMG4743	234
Atego 1315 / 1418 / 1518 / 1718	MB OM-904	04/...	N9099001	N9099001MM	970.501.02.01	AB	572x512x64	-	RMMN8900001	234
Axor 2035 / 2040 / 2044 / 2540 / 2640	MB OM-457	05/...	R7994001	R7994001MM	940.501.03.01	AB	892x630x66	-	RMMR7998001	234
L 1622	MB OM-924	01/05	A5832	A5832MM	695.501.00.01	AB	600x607x50	G9102MM	RMMA5826	235
L-1218 / L-1418 / L-1620 / LK-1620	MB OM-904 / OM-366	97/05	A192039	A192039MM	695.501.70.01	AB	420x552x52	96559MM	RMMA152022	235
L-1620 Eletrônico	MB OM-906	06/...	W4729001	W4729001MM	A 695 501 0901	AB	600x637x64	X3732001MM	RMM94546	ND
LS 1634/45	MB OM-447	02/06	A5829	A5829MM	695.501.04.01	AB	600x1012x52	-	RMMA5821	235
LS-1630 / LS-1935 / LS-1941	MB OM-449 / OM447	90/98	A192075	A192075MM	386.500.83.01 388.501.82.01	AB	697x591x50	90399MM	-	235
LS-1938 / LS-2638	MB OM-457	98/05	53342	53342MM	696.501.70.01	AB	600x1012x52	96560MM	RMM53359	235

ÔNIBUS / BUS / AUTOBUS

LO-610	MB OM-364	01/03	C0464	C0464MM	688.501.01.01	AB	450x607x30	-	RMCC0463	235
LO-814 / LO-914	MB OM-364 / OM-904	96/02	L0212	L0212MM	668.500.03.00	AB	572x432x52	-	RMML0826	235
LO-914 / LO-915	MB OM-904	03/...	C0466	C0466MM	688.501.02.01	AB	450x607x50	G9119MM	RMM49212	235
OF-1417	MB OM-904	98/04	53672	53672MM	688.501.71.01	AB	450x607x50	-	RMM49212	234
OF-1418 / OF-1722 Autom.	MB OM-904 170cv	02/...	L1092	L1092MM	384.500.08.02 384.501.01.01	AB	600x612x50	-	RMMA5826	ND
OF-1722	MB OM-924	01/05	A5832	A5832MM	695.501.00.01	AB	600x607x50	G9102MM	RMMA5826	235
OH-1318 / OH-1418 / OH-1420 / OH-1521 / OH-1620	MB OM-352 OM-904 / OM-336	95/...	A192769	A192769MM	684.501.73.03 382.501.75.01	AB	535x612x52	-	-	235

BLOCOS / CORES / PANALES

RADIADORES / RADIATORS / RADIADORES

1215 C / L-1218 EL / 1318 EL OF-1417 / LO-914 / LO-915	MB OM-904	98/...	53358	53358MM	-	CuZn	450x615x47	-	RMM57054 RMM49212	235
1938 S / 1944	MB OM-457	01/06	E1017	E1017MM	-	AB	974x668x42	-	RMM67143	236
Accelo 715 C / 915 C	MB OM-612/ OM-904	04/...	G7555	G7555MM	-	AB	504x474x40	-	RMMG4743	236
L-1214 / L-1218 / L-1618 / L-1621/ OF-1318 / OH1314 / OH-1315 / OH1318	MB OM-366/ OM-904/ OM-366	89/96 95/...	A250555	A250555MM	-	CuZn	660x674x40	-	RMMA150560	236
L-1218 / L-1418 / L-1620 / LK-1620	MB OM-904 / OM-366	97/05	A252022	A252022MM	-	CuZn	544x615x47	-	RMMA152022	236
L-709 / LO-809	MB OM-364	88/93	A250539	A250539MM	-	CuZn	475x510x40	-	RMMA150539	236

INTERCOOLERS / INTERCOOLERS / INTERCOOLERS

1938 S / 1944	MB OM-457	01/06	G9114	G9114MM	-	AB	630x892x62	67159MM	-	236
---------------	-----------	-------	-------	---------	---	----	------------	---------	---	-----

Obs.: AB - Alumínio brasado
AE - Alumínio expandido
CuZn - Cobre/ Latão
ND - Desenho não disponível



Linha de produtos Magneti Marelli
Linha térmica



Modelo	Motor	Ano	Ref. Behr	Código MM	Nº original	TECH	HxLxE (mm)	Bloco	Intercooler	Pag.
2423 B / 2423 K / 2428 / L-2423 / OF-1723	MB OM-906	01/...	G9118	G9118MM	-	AB	600x607x50	87940MM	-	236
L-1218 / L-1418 / L-1620 / LK-1620 / OF-1721 / LS-1414 / 1214 C	MB OM-904 / OM-366 / OM-364	97/05	96559	96559MM	-	AB	420x552x52	A192039MM	-	236
L-1620 Eletrônico	MB OM-906	06/...	X3732001	X3732001MM	-	AB	600x637x64	W4729001MM	-	ND
L-1622 / OF-1722	MN OM-924	01/...	G9102	G9102MM	-	AB	600x607x50	A5832MM	-	236
L-1630 / L-1633 / L-1935 / L-1940 / L-1941 / L-2635 / LS-1935 / LS1938	MB OM-449 / OM-447 / OM-457	94/05	90399	90399MM	-	AB	697x591x50	A192075MM	-	236
LO-914 / LO-915	MB OM-904	03/...	G9119	G9119MM	-	AB	450x607x50	C0466MM	-	236
LS-1634 / LS-1645 / LS-1938 / LS-2638	MB OM-457 / OM-447	98/06	96560	96560MM	-	AB	600x1012x52	53342MM	-	237

TANQUE DE COMPENSAÇÃO / SURGE TANKS / TANQUE DE COMPENSAÇÃO

1938 S	MB OM-457 380cv	01/06	B8358	B8358MM	693.500.71.49 958.500.01.49	-	-	-	-	237
712 C / 914 C / 1215 C / 1418 / 1721	MB OM-904 122cv	98/04	A9238	A9238MM	674.500.00.49	-	-	-	-	237
912 / L-709 / LO-809 / LO-812	MB OM-364	88/93	A310642	A310642MM	688.500.72.49	-	-	-	-	237
Accelo 715 C	MB OM-612	04/...	G7562	G7562MM	979.500.04.49	-	-	-	-	237
Accelo 915 C	MB OM-904	04/...	G7560	G7560MM	979.500.03.49	-	-	-	-	237
LKA-1418 / 1929 / 2225	-	-	A310564	A310564MM	384.500.71.49	-	-	-	-	237
O-400	MB OM-457 360cv	94/97	95327	95327MM	629.500.00.49	-	-	-	-	237
OF-1318 / OF-1620	MN OM-366 170cv	89/98	A310565	A310565MM	384.500.73.49	-	-	-	-	237

VISCO-FAN / VISCO-FAN / VENTILADOR VISCOSO

1632 / 2423 / 2428 / L-1620 Eletrônico	MB OM-906	99/...	F1448	F1448MM	906.200.07.23	Bi-metal	-	-	-	237
1938 S	MB OM-457	00/06	88868	88868MM	000.200.62.23	Bi-metal	-	-	-	237
1944 S	MB OM-457	02/06	C0467	C0467MM	000.200.80.22	Bi-metal	-	-	-	237
Accelo 915	MB OM-904	04/...	F6190	F6190MM	376.200.71.23 904.200.06.23 904.200.14.23	Bi-metal	-	-	-	238
L-1218 / L-1418 / L-1620 / LK-1620 / OF-1721	MB OM-904/ OM-366	98/05	F6190	F6190MM	376.200.71.23 904.200.06.23 904.200.14.23	Bi-metal	-	-	-	238
L1630 / L-1935 / L-1941 / L-2325	MB OM-447	90/00	57051	57051MM	000.200.28.23	Bi-metal	-	-	-	238
LS-1938	MB OM-457	98/05	83618	83618MM	000.200.61.23	Bi-metal	-	-	-	238
O-400 / OH-1628 / OH-1636	MB OM-457 OM-449/ OM-447	94/06	D2828	D2828MM	475.205.01.06 475.205.79.06	Bi-metal	-	-	-	238

EMBREGEM VISCOSA / CLUTCHES / EMBRAGUE

712 C / 914 C / 1214 C / LO-914 / LO-915	MB OM-904	98/04	E4658	E4658MM	904.200.11.22	Bi-metal	-	-	-	238
L-1218 / L-1418 / L-1620 / L-1622 / LK-1620 / OF-1721	MB OM-904	97/05	F6683	F6683MM	904.200.18.22	Bi-metal	-	-	-	238

HELICE / FAN / HELICE

L-1218 / L-1418 / L-1620 / LK-1620 / OF-1721	MB OM-904	97/05	D9271	D9271MM	904.205.07.06	-	-	-	-	238
--	-----------	-------	-------	---------	---------------	---	---	---	---	-----

DEFLETORES / SHROUD / DEFLETORES

1944	MB OM-457	01/06	C8041	C8041MM	693.505.01.55	-	-	-	-	238
1215 C / L-1218 / L-1418 / LO-914 / OF-1417	MB OM-904 152cv	96/06	C8038	C8038MM	384.505.71.30	-	-	-	-	238
1723 / 2423	MB OM-906	98/07	C8031	C8031MM	693.505.73.30	-	-	-	-	238
1938 S	MB OM-457	01/06	C8033	C8033MM	693.505.70.55	-	-	-	-	238
2428 Canavieiro	MB OM-906	99/...	C8036	C8036MM	693.505.77.30	-	-	-	-	238
915 C	MB OM-904	04/...	G7556	G7556MM	979.505.01.55	-	-	-	-	239
L-1218 / L-1418 EL / L-1620 / LK1620	MB OM-904/ OM-366	97/05	D5094	D5094MM	695.505.70.30	-	-	-	-	239
L-1620 Eletrônico	MB OM-906	06/...	C8036	C8036MM	693.505.77.30	-	-	-	-	238
L-1622 / OF-1722	MB OM-924	01/...	C8037	C8037MM	695.505.72.30	-	-	-	-	239
LO-610	MB OM-364 109cv	01/03	C8042	C8042MM	688.505.03.55	-	-	-	-	239
LO-915	MB OM-904	04/...	G8703	G8703MM	688.505.04.55	-	-	-	-	239
LS 1634/45	MB OM-447	02/06	C8035	C8035MM	695.505.00.55	-	-	-	-	239
LS-1632	MB OM-449	99/02	C8026	C8026MM	695.505.71.30	-	-	-	-	239
OF-1418	MB OM-904	03/...	G8746	G8746MM	384.505.01.55	-	-	-	-	239

SCANIA

RADIADORES / RADIATORS / RADIADORES

Série 4 - P124 / R124 / T124 completo	Scania 360/ 400/ 420cv	98/07	M4512001	RMMM4512001	1442751	AB	860x938x42	90403MM	W5058001MM	239
Série 4 - P124 / R124 / T124 sem laterais	Scania 360/ 400/ 420cv	98/07	L0001	RMLL0001	1442751	AB	860x938x42	90403MM	W5058001MM	239

Obs.: AB - Alumínio brasado
AE - Alumínio expandido
CuZn - Cobre/ Latão
ND - Desenho não disponível



Linha de produtos Magneti Marelli
Linha térmica



linha térmica

Modelo	Motor	Ano	Ref. Behr	Código MM	Nº original	TECH	HxLxE (mm)	Bloco	Intercooler	Pag.
--------	-------	-----	-----------	-----------	-------------	------	------------	-------	-------------	------

INTERCOOLERS / INTERCOOLERS / INTERCOOLERS

Série 2 - T112 / T142 / R142 e Série 3 - K113	Scania	81/98	40652	40652MM	524305 / 1100086	AB	672x650x52	84624MM	-	239
Série 4 - P114 / R114 / T114 / P124 / R124 / T124	Scania	98/07	W5058001	W5058001MM	1516492	AB	792x828x66	F0679MM	RMMM4512001	239

BLOCOS / CORES / PANALES

RADIADORES / RADIATORS / RADIADORES

Série 4 - P114 / R114 / T114 / P124 / R124 / T124	Scania 322 / 360 / 400 / 420cv	98/07	90403	90403MM	-	AB	860x938x42	-	RMMM4512001	240
Série 5 - Linha R70 caminhão	Scânia	08/...	W2574001	W2574001MM	-	AB	860x928x80	-	-	240
Série 5 - Linha R caminhão	Scânia	08/...	W2575001	W2575001MM	-	AB	860x998x86	-	-	240
Série 5 - Linha P Ônibus	Scânia	08/...	W2576001	W2576001MM	-	AB	860x688x60	-	-	240

INTERCOOLERS / INTERCOOLERS / INTERCOOLERS

Série 2 - T112 / T142 / R142 e Série 3 - T113 / K113	Scânia	81/98	84624	84624MM	-	AB	672x652x52	40652MM	-	240
Série 4 - P114 / R114 / T114 / P124 / R124 / T124	Scania 322 / 360 / 400 / 420cv	98/07	F0679	F0679MM	-	AB	792x828x66	W5058001MM	-	ND
Série 4 - P114 / R114 / T114 / P124 / R124 / T124 (Exportação)	Scania 322 / 360 / 400 / 420cv	98/07	H1335	H1335MM	-	AB	792x828x66	W5058001MM	-	ND
Série 5 - Linha R caminhão	Scânia	08/...	W0510001	W0510001MM	-	AB	826x792x64	-	-	240
Série 5 - Linha P Ônibus	Scânia	08/...	W0511001	W0511001MM	-	AB	826x572x64	-	-	240

VISCO-FAN / VISCO-FAN / VENTILADOR VISCOSO

Série 4 - P94	Scania 220/ 260/ 300cv	98/07	E4661	E4661MM	1423891	Bi-metal	-	-	-	240
Série 4 - P114 / P124	Scania 360/ 400/ 420cv	98/07	G7549	G7549MM	1402869	Bi-metal	-	-	-	240
Série 4 - R124 / T124	Scania 360/ 400/ 420cv	98/07	E4660	E4660MM	1393424	Bi-metal	-	-	-	240

VOLKSWAGEN

RADIADORES / RADIATORS / RADIADORES

8-150	MWM 4.10	00/05	64384	RMM64384	2VD121253	CuZn	500x625x47	A58121	-	241
17-300 / 18-310 / 26-300 / 40-300	Cummins 6BTAA	00/06	A64829	RMM64829	2VT121253A	CuZn	796x625x47	-	-	241

INTERCOOLERS / INTERCOOLERS / INTERCOOLERS

1622 / 2422 (Betoneira)	Cummins 6CTAA	91/01	C0479002	C0479MM	2VU117249	AB	588x632x52	-	-	230
14-220 / 16-220 / 16-300 / 17-170 / 24-220 / 24-250 / 35-300	Cummins 6CTAA/ 6BTAA	91/02	A192824	A192824MM	2RT117249A XC456K775BA	AB	588x624x52	-	-	230
8-140 / 12-140	MWM 4.10	94/02	A192953	A192953MM	XC456K775AA/AB	AB	568x376x50	-	-	230

BLOCOS / CORES / PANALES

RADIADORES / RADIATORS / RADIADORES

8-150 / 13-150	MWM 4.10	00/06	A58121	A58121MM	-	CuZn	500x625x47	-	RMM64384	231
----------------	----------	-------	--------	----------	---	------	------------	---	----------	-----

INTERCOOLERS / INTERCOOLERS / INTERCOOLERS

14-220 / 16-220 / 16-300 - 16-220 / 16-300 / 17-170 / 24-220 / 24250 / 35-300	Cummins 6BTAA/ 6CTAA	91/00	90401	90401MM	-	AB	588x624x52	-	A192824MM	231
---	----------------------	-------	-------	---------	---	----	------------	---	-----------	-----

VOLVO

RADIADORES / RADIATORS / RADIADORES

VM 210 / VM 260	MWM5A206/ MWM7A260	06/...	P0119001	RMMP0119001	20810091	AB	710x568x52	-	P0120001MM	211
FM 10 / FM 12	320/ 340/ 380 /420cv	00/06	8MK376775421	RMM376775421	1665249 / 1676636 / 8113186 / 8112566	AB	900x730x50	-	-	211
FH 12	380 / 420 / 460cv	04/...	8MK376775431	RMM376775431	3.980.841	AB	900x900x50	-	-	211

INTERCOOLERS / INTERCOOLERS / INTERCOOLERS

VM 210 / VM 260	MWM5A206 / MWM7A260	06/...	P0120001	P0120001MM	20810103	AB	720x532x50	-	RMMP0119001	241
-----------------	---------------------	--------	----------	------------	----------	----	------------	---	-------------	-----

BLOCOS / CORES / PANALES

NL-10 / NL-12 (INTERCOOLER)	-	-	A250574	A250574MM	Rad	CuZn	880x680x60	-	-	241
NL10 / NL 12 Power	-	-	K5554	K5554MM	Intercooler	AB	877x632x52	-	-	241

CONDENSADORES / CONDENSERS / CONDENSADORES

VM 210 / VM 260	MWM5A206 / MWM7A260	06/...	R7992001	R7992001MM	20809759	AB	492X515X16	P0120001MM	RMMP0119001	241
-----------------	---------------------	--------	----------	------------	----------	----	------------	------------	-------------	-----

Obs.: AB - Alumínio brasado
AE - Alumínio expandido
CuZn - Cobre/ Latão
ND - Desenho não disponível

226



Linha de produtos Magneti Marelli
Linha térmica

BEHR 
SERVICE

MAGNETI
MARELLI



Modelo	Motor	Ano	Ref. Behr	Código MM	Nº original	TECH	HxLxE (mm)	Bloco	Intercooler	Pag.
VISCO-FAN / VISCO-FAN / VENTILADOR VISCOSO										
NH / FH 12	-	-	88863	88863MM	8149396	Bi-metal	-	-	-	241
FH/FM	-	-	8MV376731451	376731451MM	20397619 / 85000022	Bi-metal	-	-	-	241
FH 12	380 / 420 / 460cv	04/...	8MV376731481	376731481MM	20450210 / 20450240	Eletronic	-	-	-	241

DESENHOS TÉCNICOS

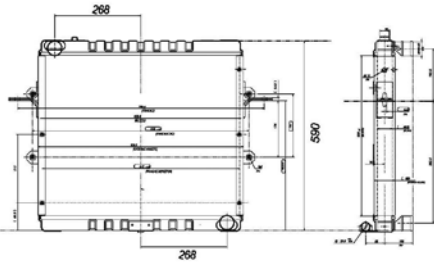

DESENHOS TÉCNICOS

RMMA61133



RMMG8441

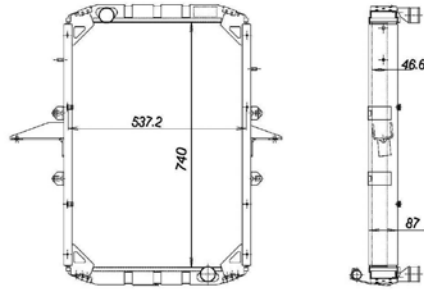

RMMG8443

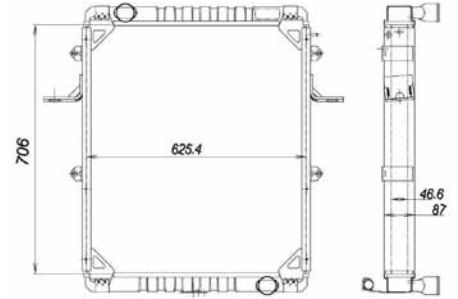

RMMG8460

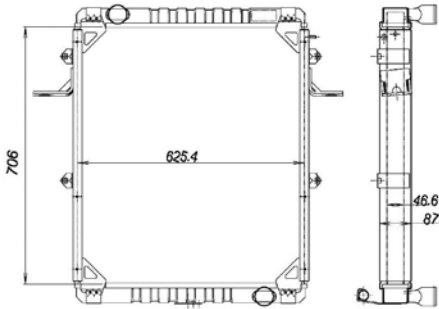

RMMN9161001

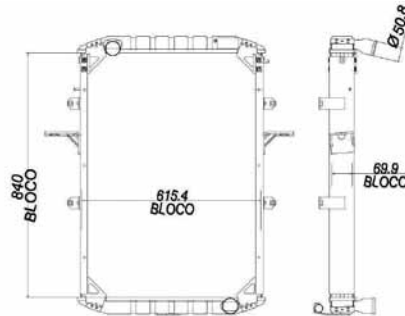

RMM49233

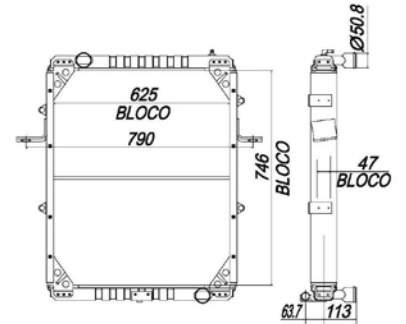

A192953MM

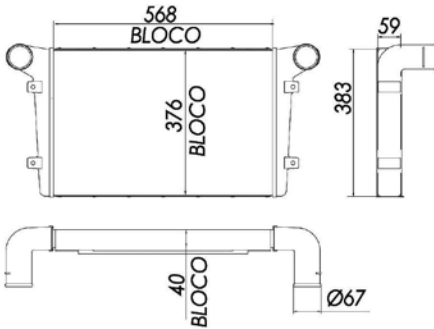

RMMG8232

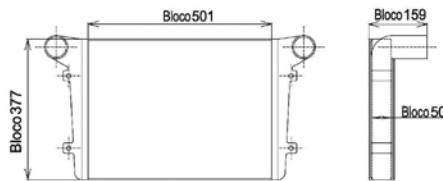

A192824MM

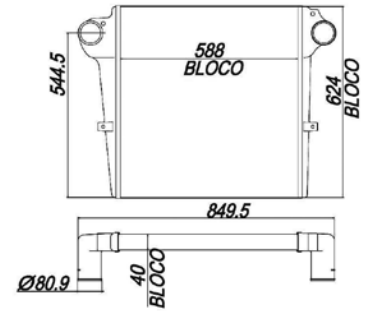

RMMC0478

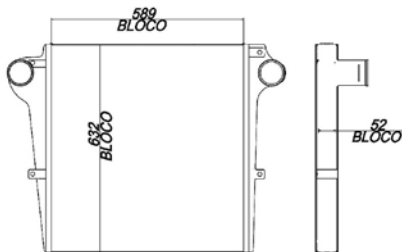

C0479MM

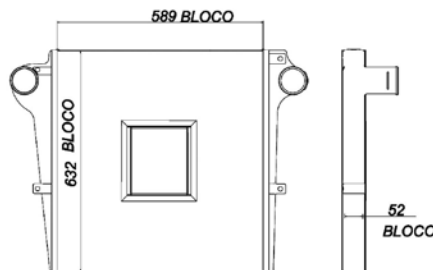

RMMN8795001



Imagem ilustrativa - radiador sem laterais

desenho técnico linha térmica

230

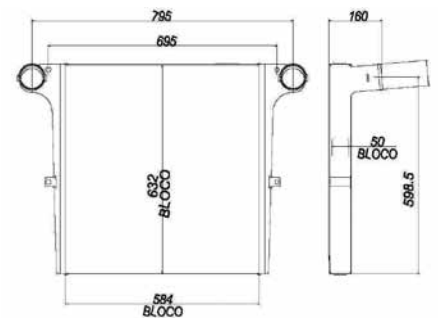

DESENHOS TÉCNICOS

RMM53354

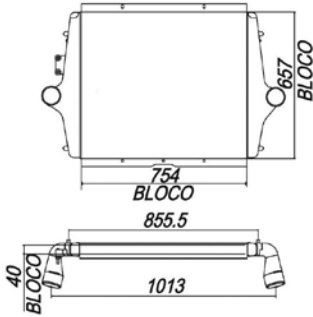

A58121MM

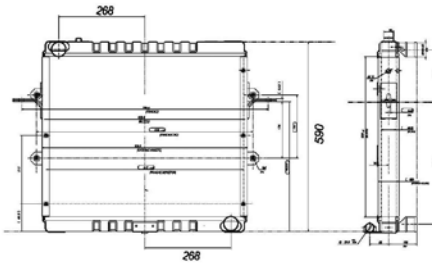

RMM53357



Imagem ilustrativa - somente o bloco

Imagem ilustrativa - somente o bloco

T3344001MM

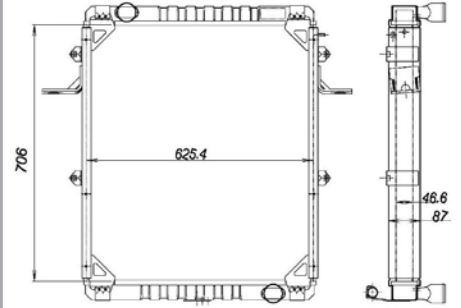
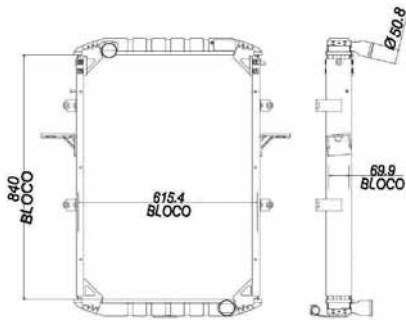

90401MM

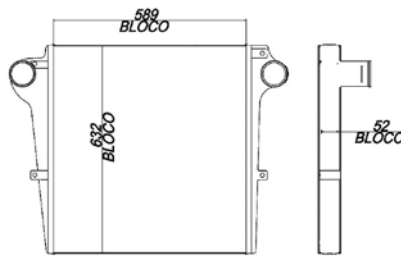

RMMR5022001

Desenho não disponível

Imagem ilustrativa - somente o bloco

Imagem ilustrativa - somente o bloco

RMM376721791

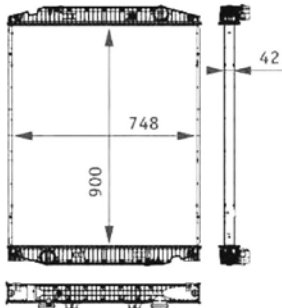

R5023001MM

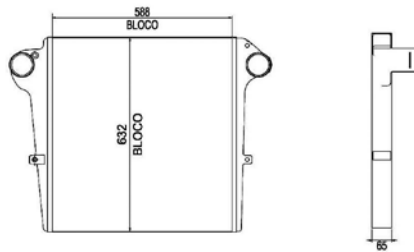

376724271MM

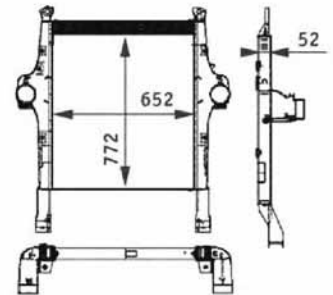

R5026001MM

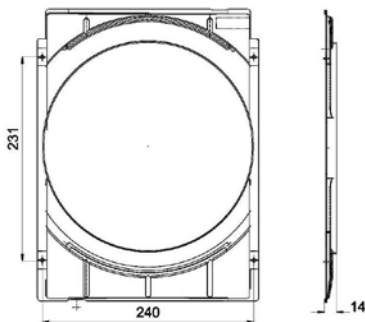

RMM57054

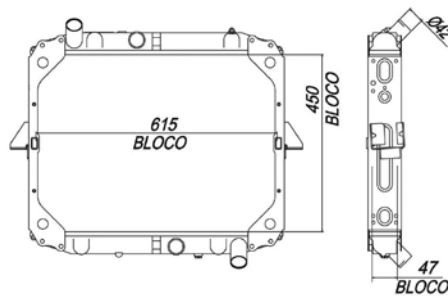

RMM67143

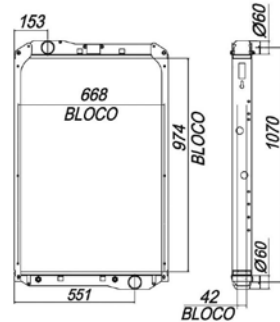



DESENHOS TÉCNICOS

RMM94546

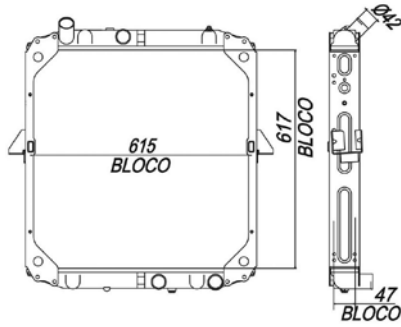

RMMA5824

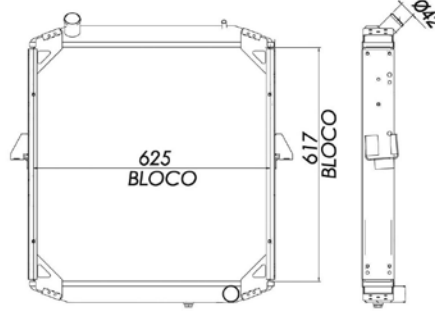

RMMN890001

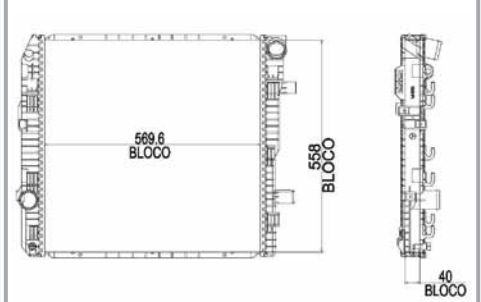

RMMG4743

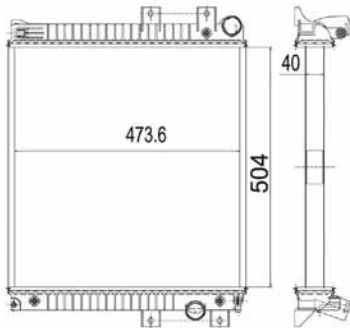

RMMR7998001



RMMA152022

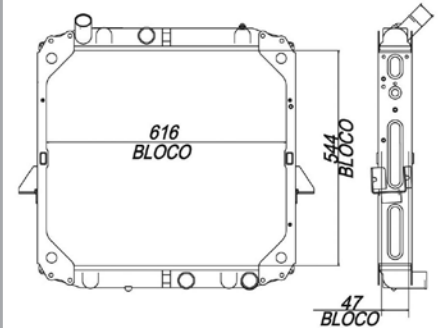

RMM94546

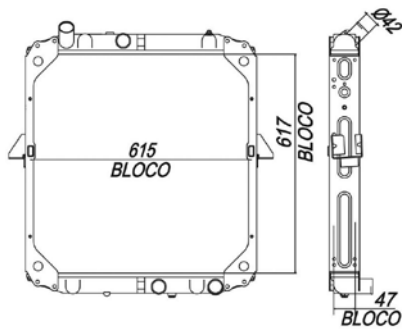

RMMA5826

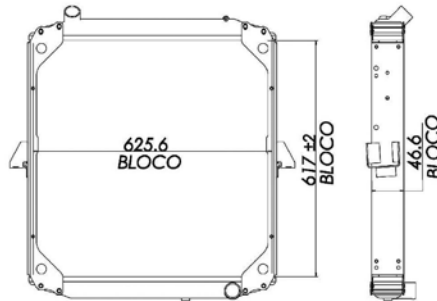

RMMA150539

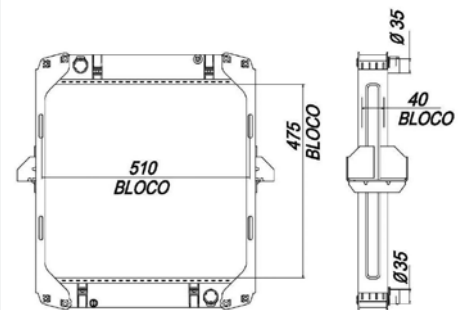

RMM53356

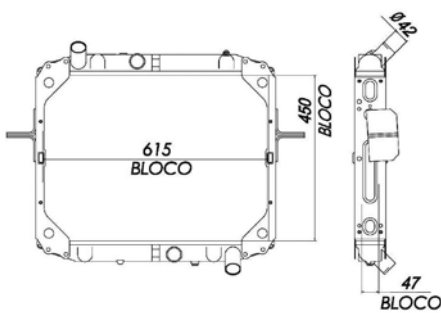

RMMA5821

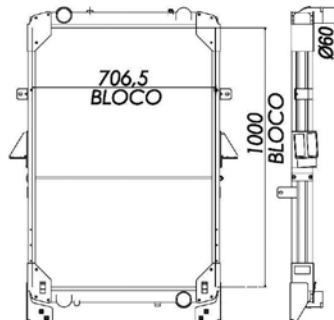

RMM53359

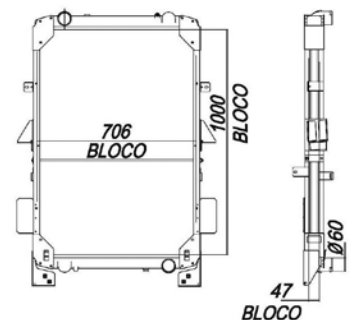

desenho técnico linha térmica

232



DESENHOS TÉCNICOS

RMM55393

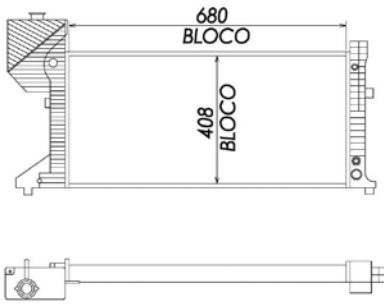

RMMD4516

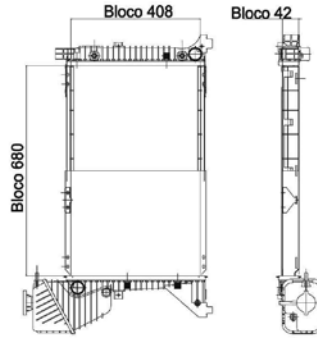

RMMC0463

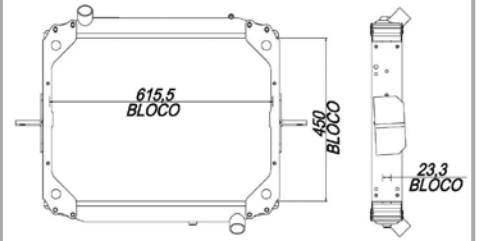

RMML0826

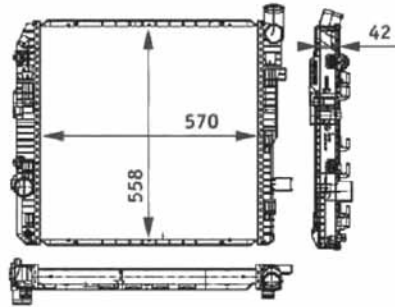

RMMA152138

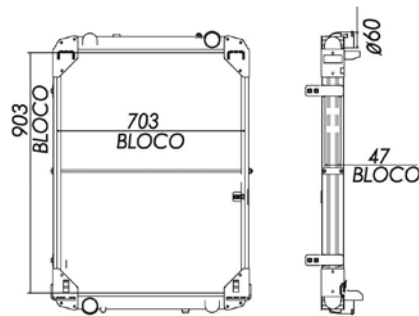

RMMA150560

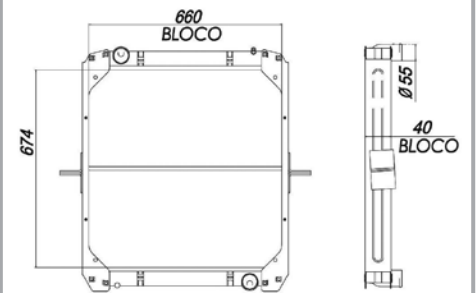

RMM49212

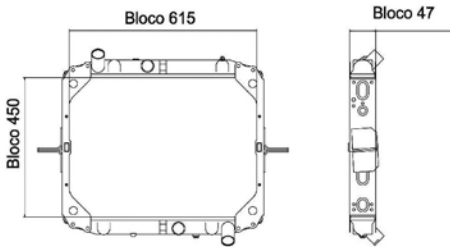

RMMA152022

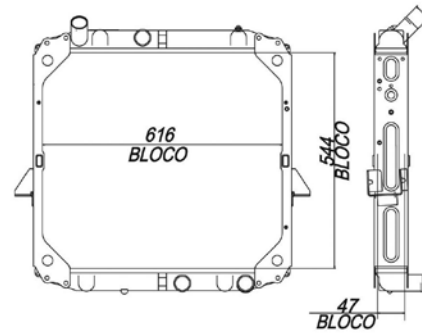

RMMA5826

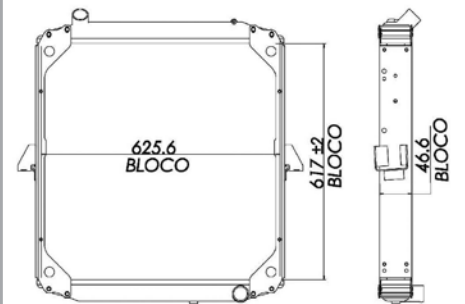

RMMA5826

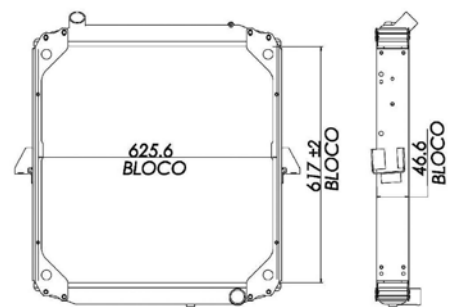

RMM53670

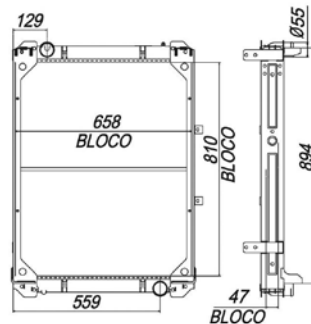

61015MM



Imagem ilustrativa - radiador sem laterais



DESENHOS TÉCNICOS

57533MM

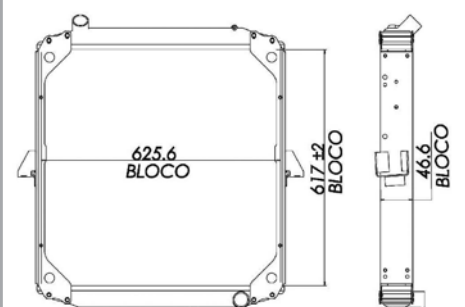

Imagem ilustrativa - radiador sem laterais

57535MM

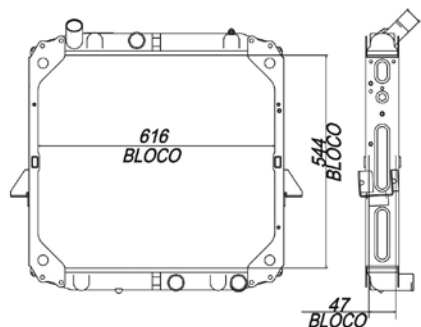

Imagem ilustrativa - radiador sem laterais

61014MM

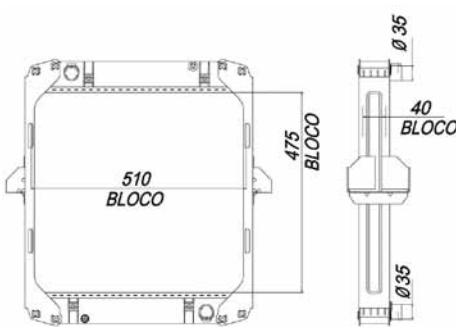

Imagem ilustrativa - radiador sem laterais

49229MM

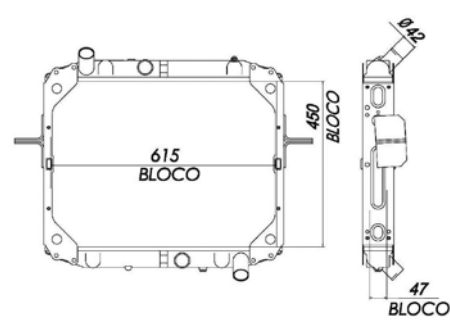

Imagem ilustrativa - radiador sem laterais

A5833MM

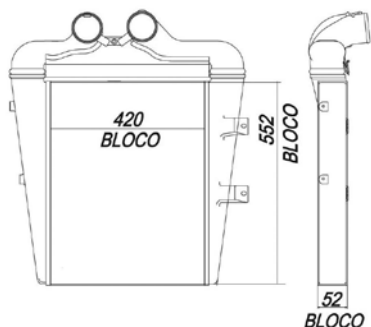

Imagem ilustrativa - radiador sem laterais

67159MM

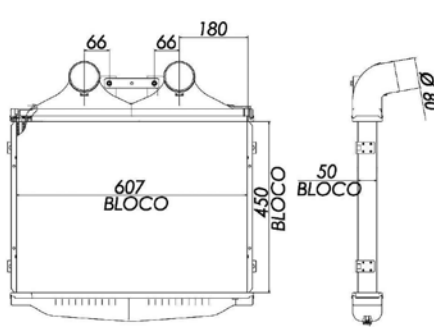

Imagem ilustrativa - radiador sem laterais

87940MM

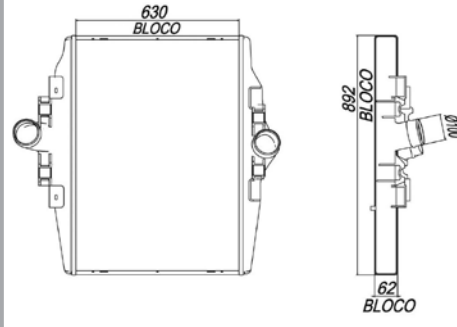

Imagem ilustrativa - radiador sem laterais

53672MM

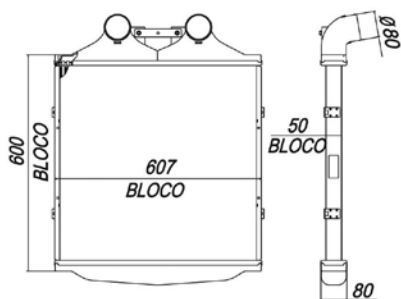

Imagem ilustrativa - radiador sem laterais

G8700MM

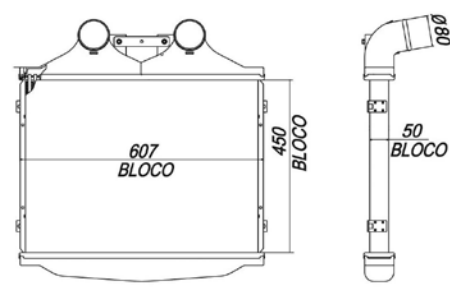

Imagem ilustrativa - radiador sem laterais

F7226MM

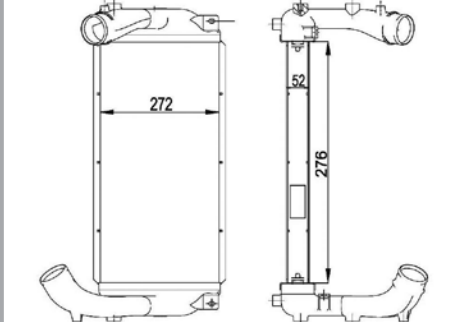

Imagem ilustrativa - radiador sem laterais

N909901MM

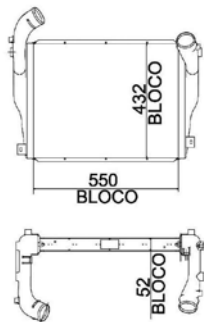

Imagem ilustrativa - radiador sem laterais

R7994001MM



Imagem ilustrativa - radiador sem laterais

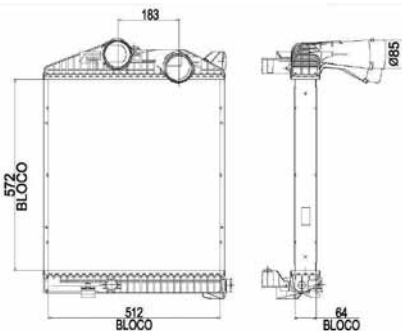

DESENHOS TÉCNICOS

A5832MM

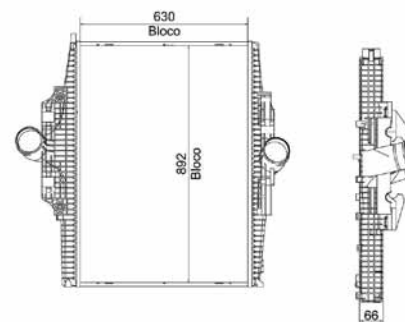
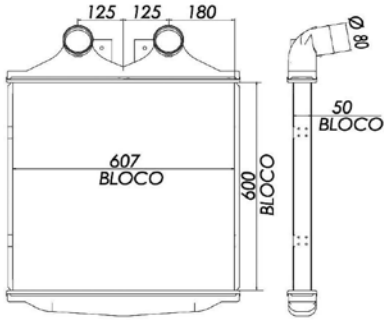

A192039MM

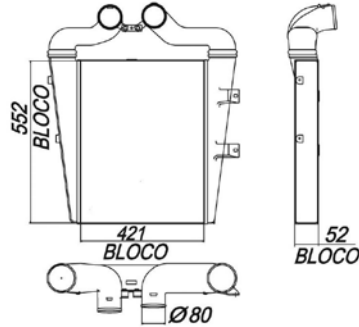

W4729001MM

Desenho não disponível

A5829MM

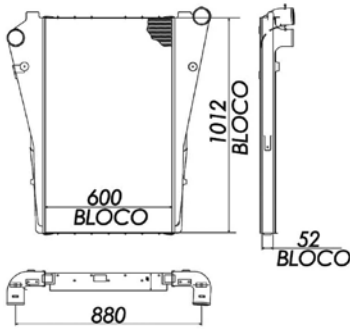

A192075MM

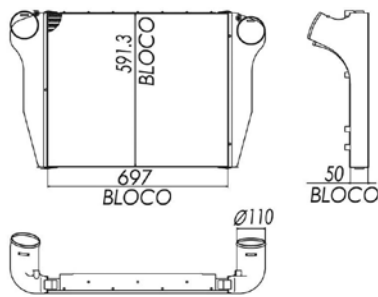

53342MM

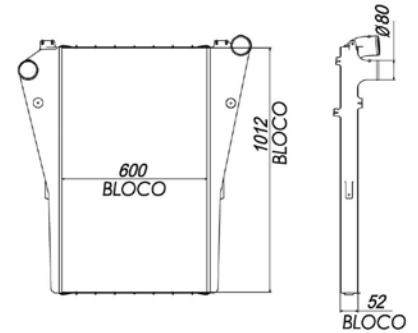

C0464MM

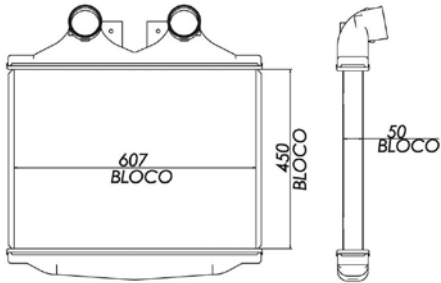

L0212MM

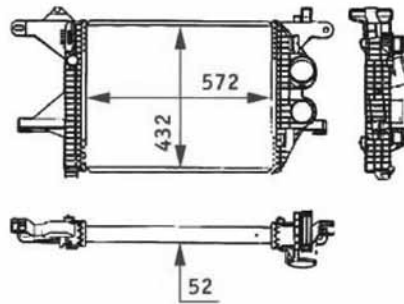

C0466MM

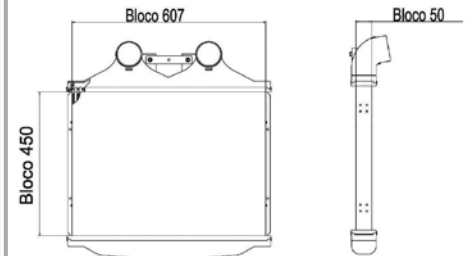

L1092MM

Desenho não disponível

A192769MM

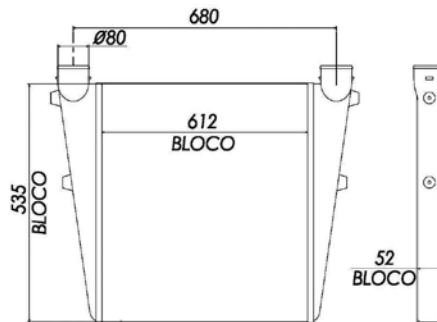

53358MM



Imagem ilustrativa - somente o bloco



DESENHOS TÉCNICOS

E1017MM

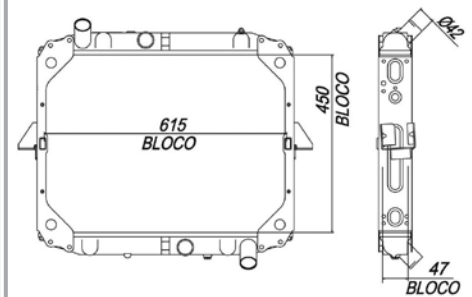

Imagem ilustrativa - somente o bloco

G7555MM

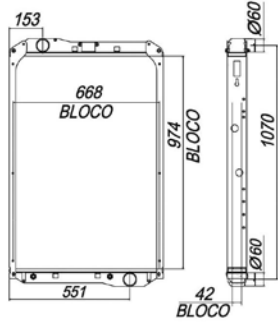

Imagem ilustrativa - somente o bloco

A250555MM

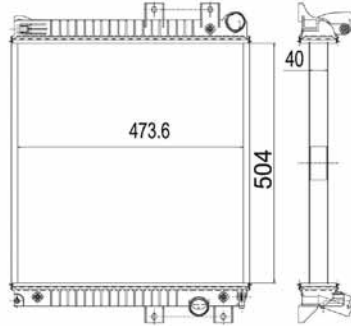

Imagem ilustrativa - somente o bloco

A252022MM

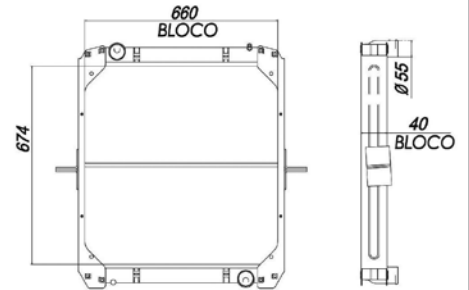

Imagem ilustrativa - somente o bloco

A250539MM

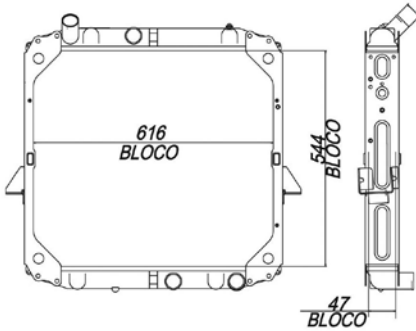

Imagem ilustrativa - somente o bloco

G9114MM

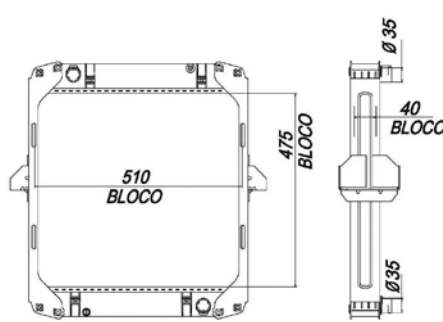

Imagem ilustrativa - somente o bloco

G9102MM

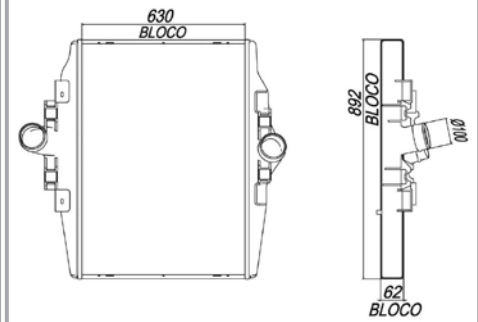

Imagem ilustrativa - somente o bloco

90399MM

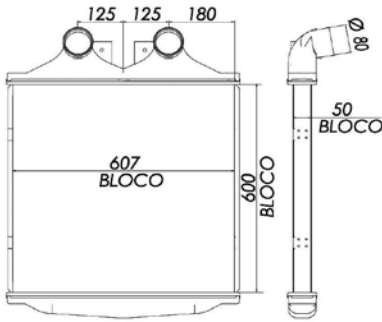

Imagem ilustrativa - somente o bloco

G9118MM

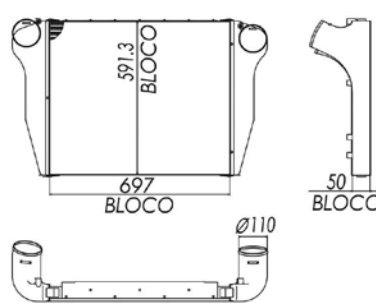

Imagem ilustrativa - somente o bloco

96559MM

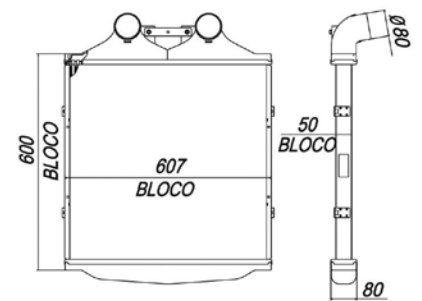

Imagem ilustrativa - somente o bloco

X3732001MM

Desenho não disponível

G9119MM

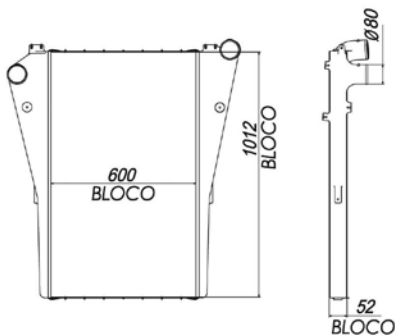

Imagem ilustrativa - somente o bloco

desenho técnico linha térmica

236

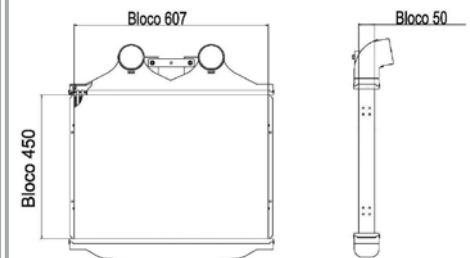

DESENHOS TÉCNICOS

96560MM



Imagem ilustrativa - somente o bloco

B8358MM



A9238MM

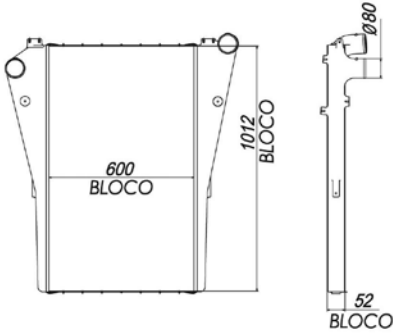
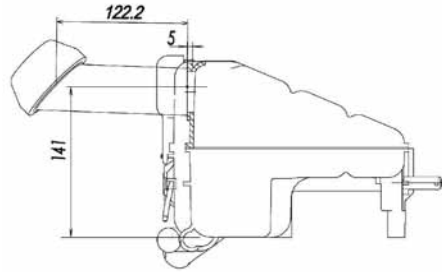
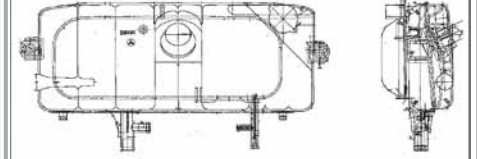

A310642MM

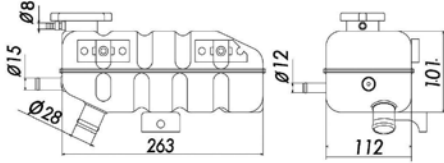

G7562MM

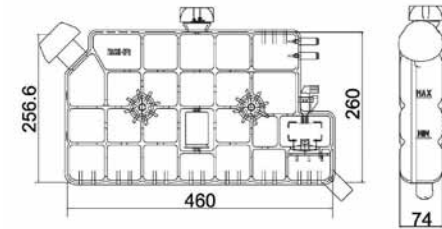

G7560MM

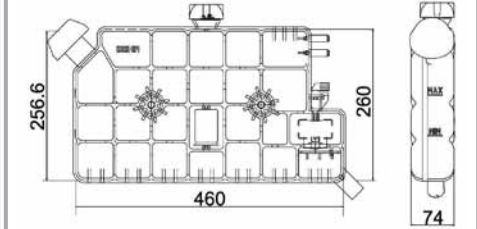

A310564MM

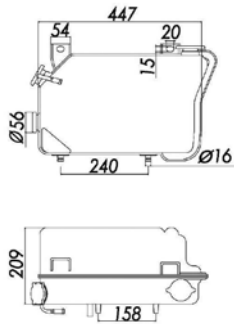

95327MM

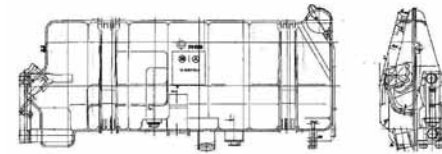

A310565MM

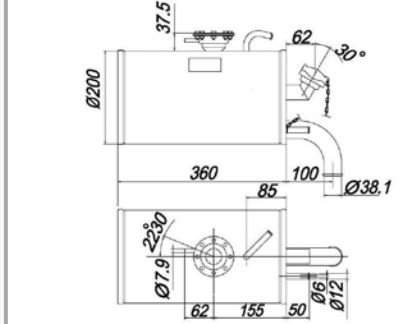

F1448MM

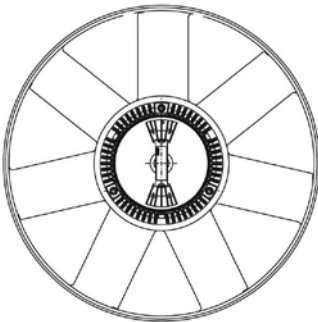

88868MM

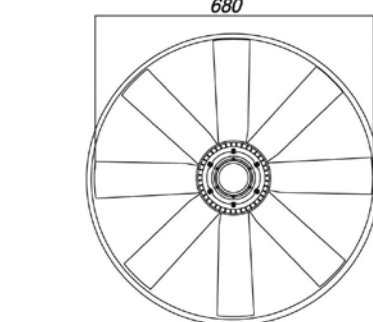

C0467MM

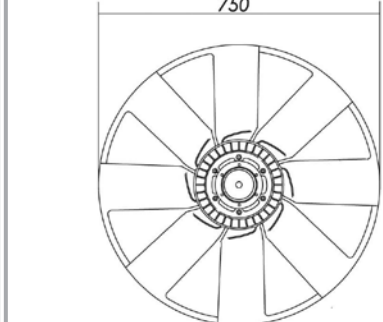



DESENHOS TÉCNICOS

desenho técnico linha térmica

238

<p>F6190MM</p>	<p>57051MM</p>	<p>83618MM</p>
<p>D2828MM</p>	<p>E4658MM</p>	<p>F6683MM</p>
<p>D9271MM</p>	<p>C8041MM</p>	<p>C8038MM</p>
<p>C8031MM</p>	<p>C8033MM</p>	<p>C8036MM</p>



DESENHOS TÉCNICOS

G7556MM

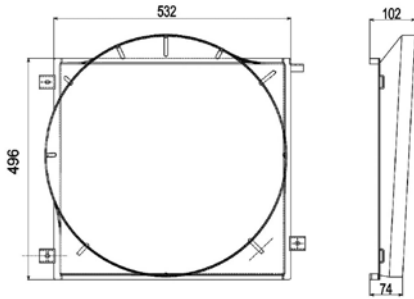

D5094MM

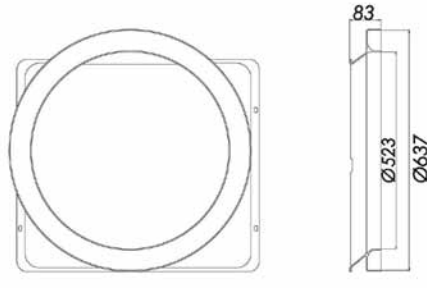

C8037MM

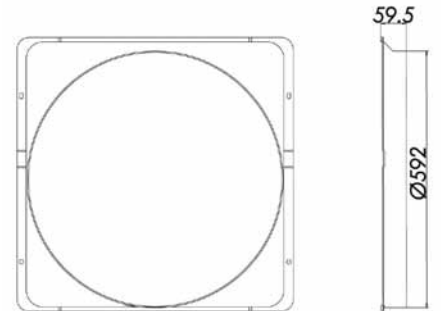

C8042MM

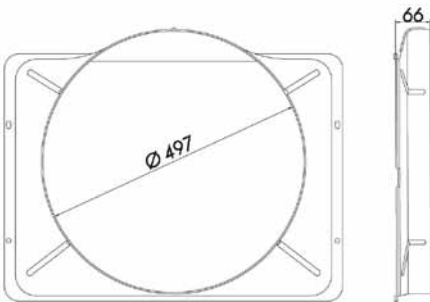

G8703MM

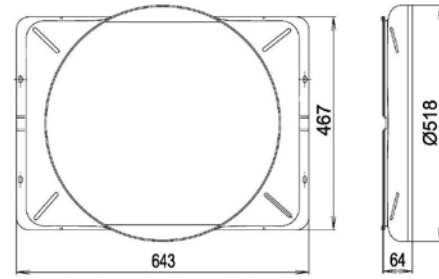

C8035MM

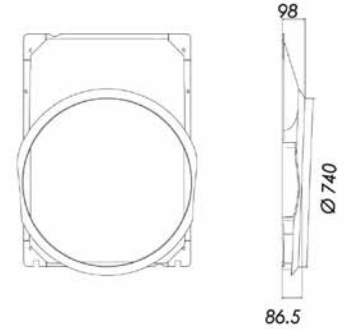

C8026MM

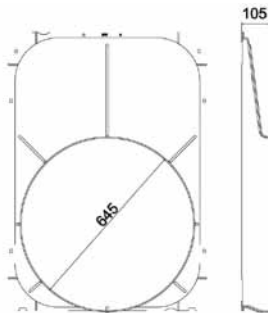

G8746MM

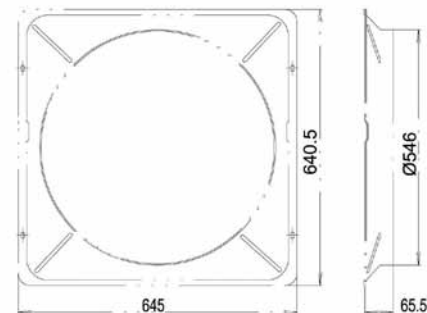

RMMM4512001

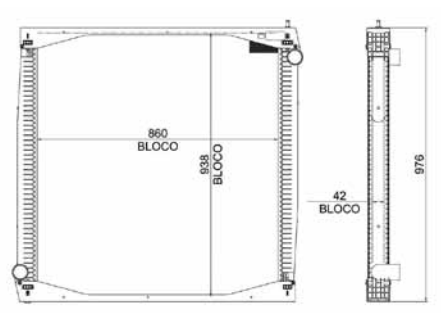

RMML001

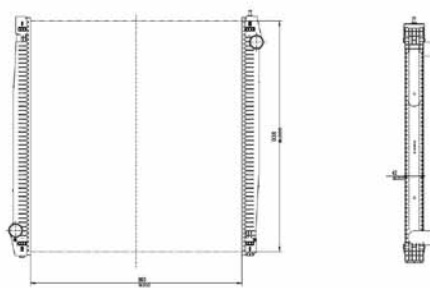

40652MM

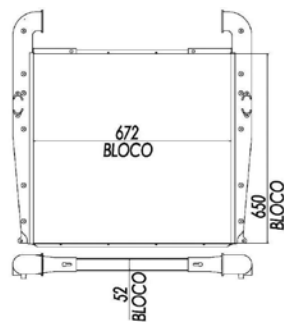

W5058001MM



Imagem ilustrativa - radiador sem laterais



DESENHOS TÉCNICOS

90403MM

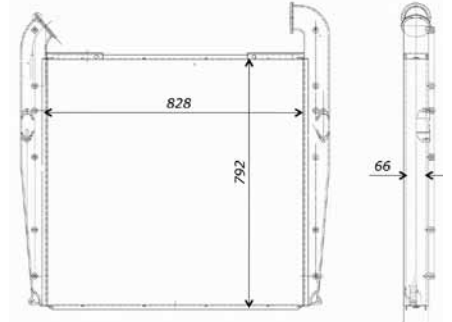

Imagem ilustrativa - somente o bloco

W2574001MM

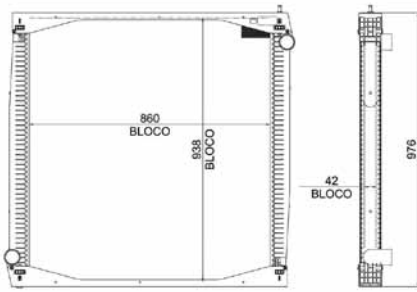

Imagem ilustrativa - somente o bloco

W2575001MM

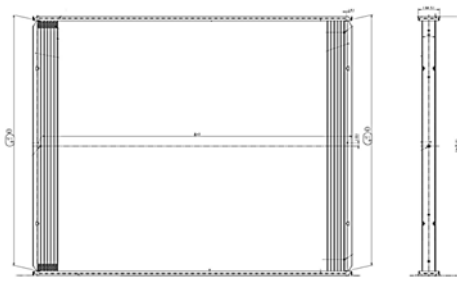

Imagem ilustrativa - somente o bloco

W2576001MM

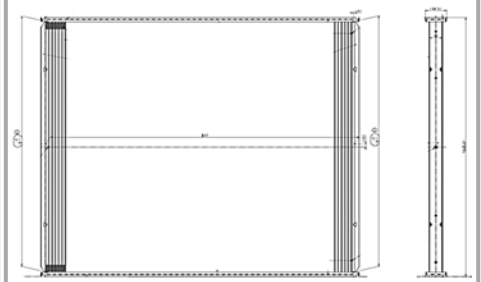

Imagem ilustrativa - somente o bloco

84624MM

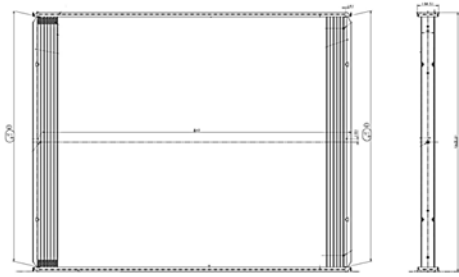

Imagem ilustrativa - somente o bloco

F0679MM

Desenho não disponível

H1335MM

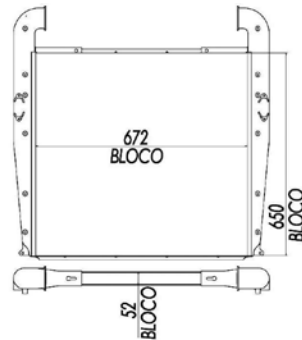
Desenho não disponível

W0510001MM



Imagem ilustrativa - somente o bloco

W0511001MM

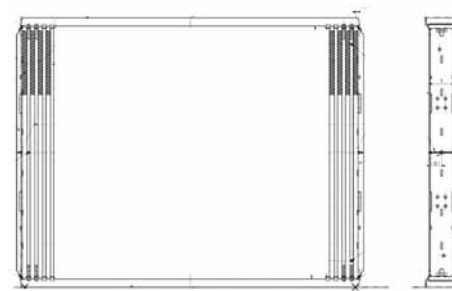

Imagem ilustrativa - somente o bloco

E4661MM



G7549MM

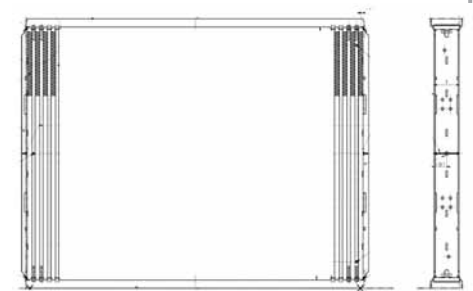
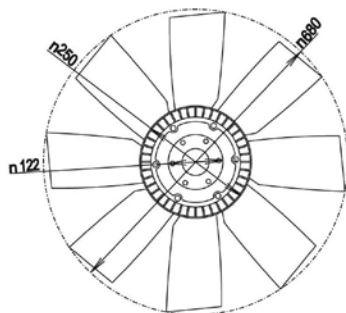
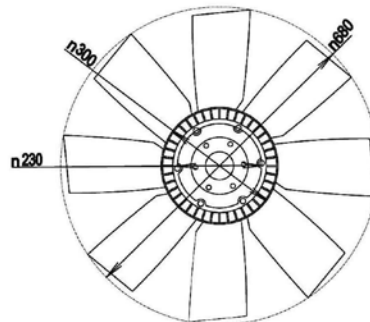

E4660MM

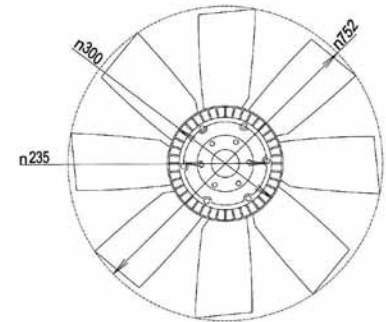

desenho técnico linha térmica

240



DESENHOS TÉCNICOS

RMM64384

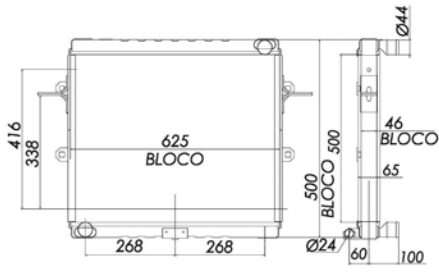

RMMA64829

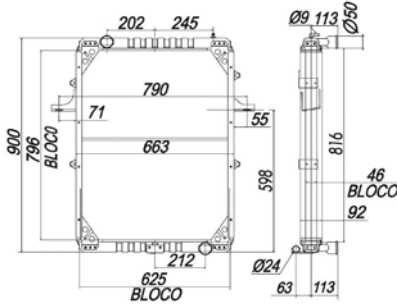

RMMP0119001

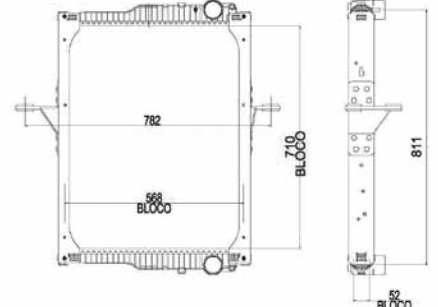

RMM376775421

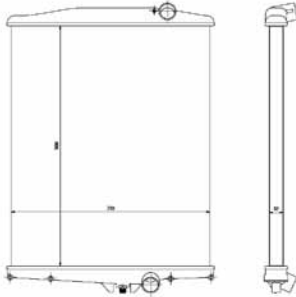

RMM376775431

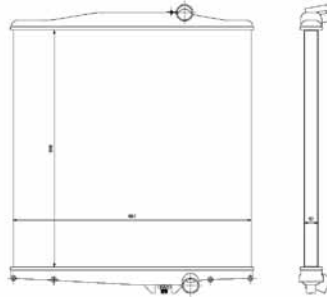

P0120001MM

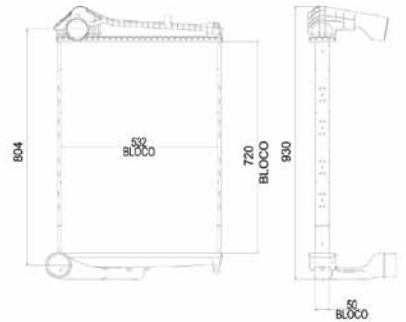

A250574MM

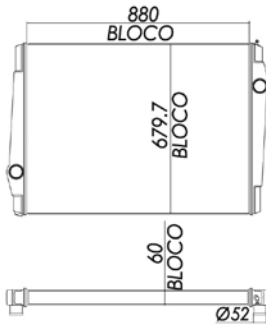

K5554MM

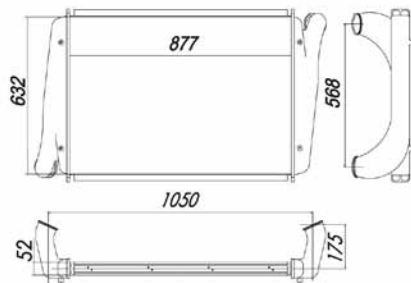

R7992001MM



Imagem ilustrativa - somente o bloco

Imagem ilustrativa - somente o bloco

88863MM

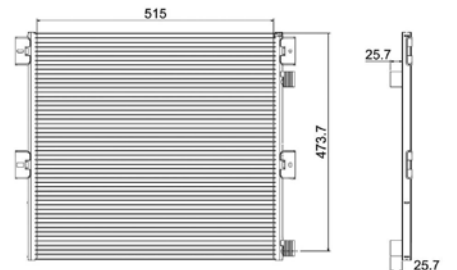
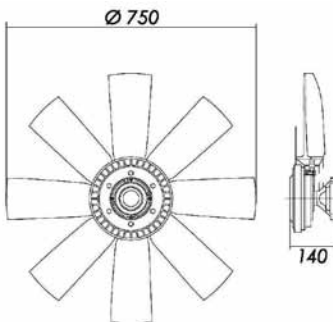

376731451MM

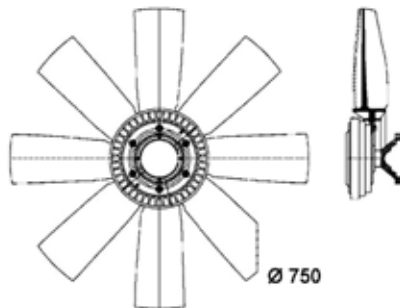

376731481MM

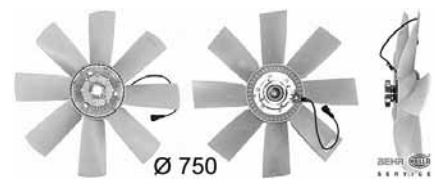

linha de
produtos

MAGNET
MARE

válvula
termostática



Cód. Magneti Marelli - MMVT332.77K



N° Original: 6L7291, 4N2212, 959160

Aplicação CARTEPILLAR

16 - Motor Graders, 571 / 583 H - Pipe Layers, 619 ao 666 Wheel Tractors - Cummins, 769/ D348/ 1673/ 1674 Truck Diesel Todos - Cummins, 910 ao 992 Traxcavators - Cummins, D330/D330B/D333B Engines Marine - Cummins, D333B/ 342C/ 379/ 398 Engines Industrial - Cummins, D7E/D8H/D8K Crawler Tractors - Cummins
TODOS DIESEL

Legenda



D1	57
d2	73
A	

P	E	F	V



77°C +/-2°C

Cód. Magneti Marelli - MMVT332.82K



N° Original: 9N2894, 9N3017, 1W5253, 5N6242, 8N4935

Aplicação CARTEPILLAR

16 - Motor Graders, 773 - Wheel Tractors, 1676/ 3408/ 3412 - Truck, 571 / 583 H - Pipe Layers, 910 até 992 - Traxcavators, 910 até 992 - Traxcavators, D330/ D330B/ D333B - Engines Marine, D333B/ 342C/ 379/ 398 - Engines Industrial, D7E/ D8H/ D8K - Crawler Tractors/ 16 Motor Graders - Cummins
TODOS DIESEL

Legenda



D1	57
d2	73
A	

P	E	F	V



82°C +/-2°C

Cód. Magneti Marelli - MMVT302.82K



N° Original: 3907242

Aplicação CUMMINS

SERIE C - 6CT 8.3

TODOS DIESEL

Legenda



D1	44
d2	30
A	35

P	E	F	V



82°C +/-2°C

Cód. Magneti Marelli - MMVT332.77K



N° Original: 204586, Y201365, 135675

Aplicação CUMMINS

SERIE C, SERIE J - 6cil., SERIE H, SERIE N - 4/6cil., SERIE N 855 - 4/6cil.,

SERIE NH, SERIE NHH - 4/6cil.

TODOS DIESEL

Legenda



D1	57
d2	73
A	

P	E	F	V



77°C +/-2°C

Cód. Magneti Marelli - MMVT332.82K



N° Original: 3002742, 17360, 301737

Aplicação CUMMINS

SERIE C, SERIE J - 6cil., SERIE H, SERIE N - 4/6cil., SERIE NH, SERIE NHH - 4/6cil.

TODOS DIESEL

Legenda



D1	57
d2	73
A	

P	E	F	V



82°C +/-2°C



Linha de produtos Magneti Marelli
Válvula Termostática



Cód. Magneti Marelli - MMVT236.71K

Aplicação MERCEDES-BENZ



N° Original: 003.203.32.75

1113/ 1114/ 1313/ 1314 - Motor OM 352, 1313A/ 1316/ 1317/ 1516/ 2216/ 2217/ 1118/
1318/ 1517/ 1518/ O365 - Motor OM 352 A, 1513/ 1514/ 2013/ 2014 - Motor OM 353,
2213/ 2214/ O364 - Motor OM 354, 608D/ 608E/ 708E - Motor OM 314,
TODOS DIESEL

Legenda



D1	67
d2	43
A	25,5

P	E	F	V
	✓		



71°C +/-2°C

Cód. Magneti Marelli - MMVT236.79K

Aplicação MERCEDES-BENZ



N° Original: 004.203.43.75

1419/ 1420/ 1517/ 1518/ 1519/ 1520/ 1819/ 2219/ 2220/ O371 - Motor OM 355-5,
1924/ O370 BR - Motor OM 355, 1924A, 1929, O370 - Motor OM 355 A,
1932, 1933, 1934 - OM 355 LA
TODOS ÁLCOOL

Legenda



D1	67
d2	43
A	25,5

P	E	F	V
	✓		



79°C +/-2°C

Cód. Magneti Marelli - MMVT236.83K

Aplicação MERCEDES-BENZ



N° Original: 003.203.31.75, 003.203.78.75, A.004.203.83.75

1214/ K1214/ L1214/ 1414/ K1414/ L1414/ L1614/ LK1614/ 1714/ K1714/ L2314 - Motor OM 366,
1218, L1218 - 1418L/ LK/ LA/ LAK - L/ LK 1618, 1718 - L/ LK/ LB 2318, 2418 - OF/ OH 1318 -
Motor OM 366 A, 709, 809 - Motor OM 364, 712, 812, 912 - OM 364 A, 914, 1114 BR - OM 364 LA,
BR 352, 355, 366, 400 / BR 900 - 4/6cil., L / LK1621, 1721 - 1721S, O371UL, OF1620 - OM 366 LA,
LA / LS1630 - OM 449, LS1625, L / LB2325 - LK2325, O400UP, O400R - OM 449 A,
LS1935, LS1941 - L / LS / LK2635 - O400RS/RSD/RSL/RSE - OM 447 LA,
TODOS DIESEL

Legenda



D1	67
d2	43
A	25,5

P	E	F	V
	✓		



83°C +/-2°C

Cód. Magneti Marelli - MMVT286.80K

Aplicação MWM



N° Original: 9.052.5.010.003.8

SÉRIE 10 (10.00, 11.01,02,03) - Motor 4.10/T/TCA, 6.10/T/TCA, SÉRIE 10 (11.05, 06,
07, 08) - Motor4.10/T/TCA, 6.10/T/TCA, SÉRIE 10 (11.09, 10, 11, 12) - 4.10/T/TCA,
6.10/T/TCA, SÉRIE 10 (11.13, 14, 17,21,01) - 4.10/T/TCA, 6.10/T/TCA, SÉRIE 10 (26,
28, 34, 36, 00,46,01) - 4.10/T/TCA, 6.10/T/TCA, SÉRIE 10 (81.00, 82.00) - 6.10T,
6.10TCA, SPRINT- X 10 - 4/6cil

TODOS DIESEL

Legenda



D1	54
d2	30
A	33

P	E	F	V



80°C +/-2°C

Cód. Magneti Marelli - MMVT214.79K

Aplicação SCANIA



N° Original: 524942

112, 113, 142, 143 T/R

TODOS DIESEL

Legenda



D1	92
d2	55
A	42,3

P	E	F	V
	✓		



79°C +/-2°C



Cód. Magneti Marelli - MMVT302.82K

Aplicação VOLKSWAGEN

14210 - 15180 - MOTOR CUMMINS 6CT 8.3
TODOS DIESEL



Nº Original: 3907242



D1	44
d2	30
A	35

P	E	F	V



82°C +/-2°C

Cód. Magneti Marelli - MMVT332.71K

Aplicação VOLVO

N10, N12
TODOS DIESEL



Nº Original: 1544683-4

Legenda



D1	57
d2	73
A	

P	E	F	V



71°C +/-2°C

Cód. Magneti Marelli - MMVT332.82K

Aplicação VOLVO

N10, N12
TODOS DIESEL



Nº Original: 1544683-4

Legenda



D1	57
d2	73
A	

P	E	F	V



82°C +/-2°C

Guia de Consulta

Letras no final do código: **K** = Kit, **C** = Carcaça/ Corpo

Cód. Magneti Marelli - MMVT208.82K

Aplicação
Fiat 147, Elba, Mile, Uno 1.0, 1.3, 1.5 Gas. .../96
Código Original 4351196 / 7500782 / 7630391

Legenda

D1	50
d2	31,5
A	27,1

P	E	F	V

82°C +/-2°C

Cód. Magneti Marelli - MMVT208.85K

Aplicação
Fiat 147, Elba, Mile, Uno 1.0, 1.3, 1.5 Alc. .../96
Código Original 4351196 / 7500782 / 7630391

Ícones:



Temperatura de abertura da válvula



Anel de vedação



Junta - representa somente sua existência e não o real formato



Válvula descentralizada

Dimensões (em milímetros)

P - Pino de desaeração

E - Entalhe

F - Furo

V - Válvula vulcanizada